

# SIEMENS

SIPART DR21  
6DR 210\*-\*

Edition 04/2003

Manual



## Classification of safety-related notices

This manual contains notices which you should observe to ensure your own personal safety, as well as to protect the product and connected equipment. These notices are highlighted in the manual by a warning triangle and are marked as follows according to the level of danger:



---

### **DANGER**

indicates an imminently hazardous situation which, if not avoided, **will** result in death or serious injury.

---

---



---

### **Warnung**

indicates a potentially hazardous situation which, if not avoided, **could** result in death or serious injury.

---

---



---

### **CAUTION**

used with the safety alert symbol indicates a potentially hazardous situation which, if not avoided, **may** result in minor or moderate injury.

---

---

---

### **CAUTION**

used without the safety alert symbol indicates a potentially hazardous situation which, if not avoided, may result in property damage.

---

---

---

### **NOTICE**

indicates a potential situation which, if not avoided, may result in an undesirable result or state.

---

---



---

### **NOTE**

highlights important information on the product, using the product, or part of the documentation that is of particular importance and that will be of benefit to the user.

---

Copyright © Siemens AG 1999 All rights reserved

The reproduction, transmission or use of this document or its contents is not permitted without express written authority. Offenders will be liable for damages. All rights, including rights created by patent grant or registration of a utility model or design, are reserved.

Siemens AG  
Bereich Automatisierungs- und Antriebstechnik  
Geschäftsgebiet Prozessinstrumentierung- und Analytik  
D-76181 Karlsruhe

Disclaimer of Liability

We have checked the contents of this manual for agreement with the hardware and software described. Since deviations cannot be precluded entirely, we cannot guarantee full agreement. However, the data in this manual are reviewed regularly and any necessary corrections included in subsequent editions. Suggestions for improvement are welcomed.

© Siemens AG 1999  
Technical data subject to change.

## **Trademarks**

SIMATIC®, SIPART®, SIREC®, SITRANS® registered trademarks of Siemens AG.

Third parties using for their own purposes any other names in this document which refer to trademarks might infringe upon the rights of the trademark owners.

## Controls and displays

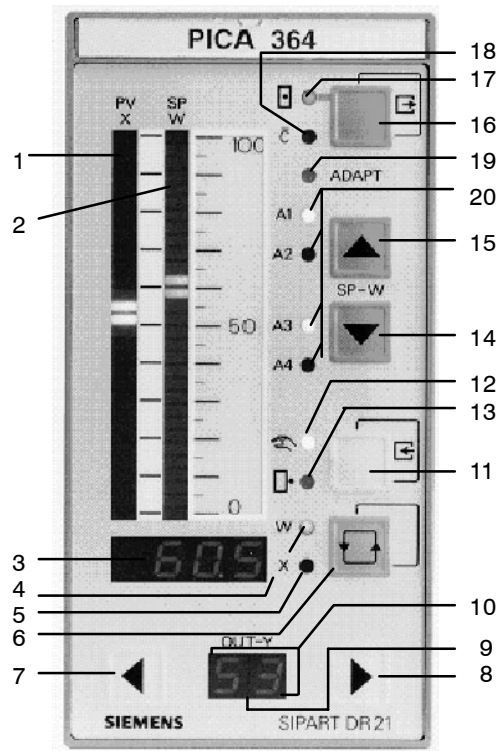

### Display of actual value and setpoint

- 1 Analog indication of actual value  $x$
- 2 Analog indication of setpoint  $w$
- 3  $w/x$  digital display (other values can be displayed)
- 4 Signalling lamp  $w$  – lights up if  $w$  is displayed
- 5 Signalling lamp  $x$  – lights up if  $x$  is displayed
- 6 Selector pushbutton for  $w/x$  digital display, acknowledgement pushbutton for flashing following return of power **or** pushbutton for entering selection mode

### Modification of manipulated variable

- 7 Pushbutton for adjustment of manipulated variable – closed (open)
- 8 Pushbutton for adjustment of manipulated variable – open (closed)
- 9  $y$  digital display
- 10 Signalling lamps of  $\Delta y$  digital outputs with S controller
- 11 Switchover pushbutton Manual/Automatic **or** “Enter” pushbutton from selection mode of configuring mode
- 12 Signalling lamp for manual mode
- 13 Signalling lamp for  $y$ -external mode

### Modification of setpoint

- 14 Pushbutton for falling setpoint
- 15 Pushbutton for rising setpoint
- 16 Selector pushbutton for internal/external setpoint **or** “Exit” pushbutton from configuring and selection modes to process operation mode
- 17 Signalling lamp for internal setpoint
- 18 Signalling lamp for computer switched off (with  $w_{ext}$ )

### Further messages

- 19 Signalling lamp for adaptation procedure running
- 20 Signalling lamp for “Limit triggered”



### Note

Operation can be blocked using the digital signal  $bLb$ ;  
exception: switching over o  $w/x$  digital display.

# Block diagram

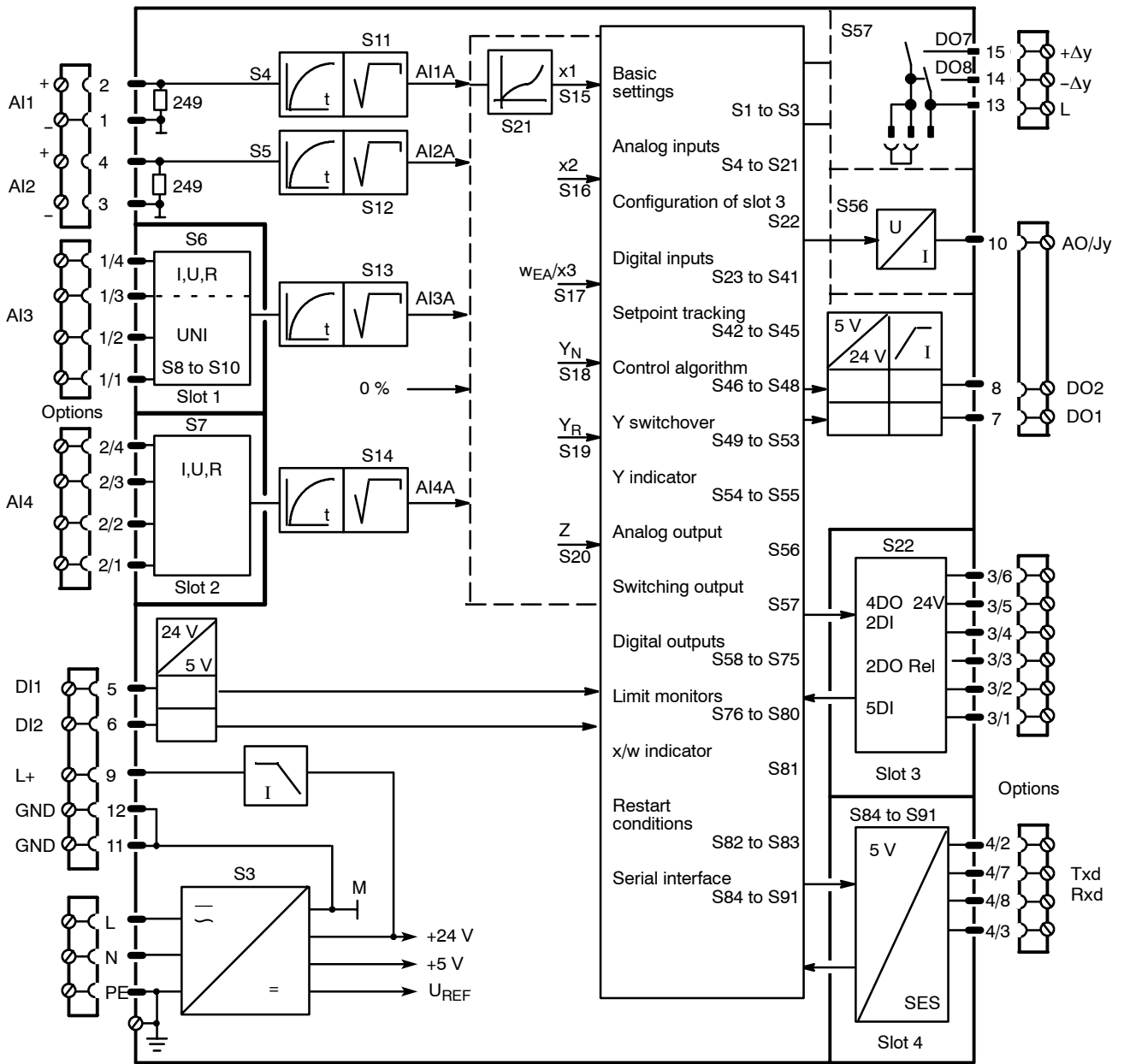

# Contents

	page
<b>1 General Part – Fundamental control technology terms</b>	<b>9</b>
<b>2 Technical Description</b>	<b>17</b>
2.1 Safety notes and scope of delivery	17
2.2 Range of Application	18
2.3 Features	19
2.4 Design	24
2.5 Function principle	26
2.5.1 Standard controller	26
2.5.2 Option module	28
2.6 Technical Data	34
2.6.1 General data	34
2.6.2 Standard controller	36
2.6.3 Option module	40
<b>3 Functional description of the structure switches</b>	<b>47</b>
3.1 General	47
3.2 Analog input signal processing (S3 to S21)	47
3.3 Digital input signal processing (S23 to S41)	50
3.4 Controller types (S1, S42 to S45)	55
3.4.1 General, recurrent functions	55
3.4.2 Fixed setpoint controller with 2 independent setpoints (S1 = 0)	59
3.4.3 Slave controller, synchronized controller, SPC-controller	62
3.4.4 DDC-Fixed setpoint controller (S1 = 2)	68
3.4.5 Controlled ratio controller (S1 = 3)	75
3.4.6 Control unit/process display (S1 = 4)	80
3.4.7 Fixed setpoint controller with one setpoint (control system coupling)	89
3.4.8 Slave controller without Int/Ext -switching (control system coupling)	90
3.5 Control algorithm	91
3.6 Controller output structures (S2, S49 to S55)	94
3.7 Analog output signal processing (S56)	110
3.8 Digital output signal processing (S57 to S75)	111
3.9 Adaptation (S48)	113
3.10 Other functions of the standard controller	115
3.10.1 Adaptive filter	115
3.10.2 Response threshold AH	116
3.10.3 Limit value alarm (S76 to S80)	117
3.10.4 Linearizer (S21, oFPA)	118
3.10.5 Restart conditions (S82, S83)	120
3.10.6 Serial interface and PROFIBUS-DP (S84 to S91)	120
<b>4 Installation</b>	<b>121</b>
4.1 Mechanical Installation	121
4.1.1 Work prior to installation	121
4.1.2 Installing the controller	124
4.1.3 Installation of the options modules	125
4.2 Electrical Connection	126
4.2.1 Warnings and block diagram	126
4.2.2 Connection standard controller	130
4.2.3 Connection of the options modules	133
4.2.3.1 Modules for analog measuring inputs	133
4.2.3.2 Connection examples for analog measuring inputs with the module 6DR2800-8J	137
4.2.3.3 Modules for expanding the digital inputs and digital outputs	142
4.2.4 Connection of the interface module 6DR2803-8C	144
4.2.4.1 RS 232 point-to-point (END/END)	144
4.2.4.2 RS 485 bus	145
4.2.4.3 PROFIBUS-DP, 6DR2803-8P	146

<b>5</b>	<b>Operation</b>	<b>149</b>
5.1	General	149
5.2	Process operation mode	150
5.3	Selection mode	152
5.4	Configuration modes	154
5.4.1	General, Online and Offline modes	154
5.4.2	Configuration mode online-parameters onPA	155
5.4.3	Configuration mode adaptation AdAP	156
5.4.4	Configuration level offline parameters oFPA	163
5.4.5	Configuration mode structure switch StrS	165
5.4.6	Set UNI-module CAE3	173
5.4.6.1	Measuring range for mV (S8 = 0)	175
5.4.6.2	Measuring range for U, I (S8 = 0)	175
5.4.6.3	Measuring range for thermocouple with internal reference point (S8 = 1)	175
5.4.6.4	Measuring range for thermocouple with external reference point (S8 = 2)	176
5.4.6.5	Measuring range for PT100 four-wire and three-wire connection (S8 = 3,4)	176
5.4.6.6	Measuring range for PT100 two-wire connection (S8 = 5)	177
5.4.6.7	Measuring range for resistance potentiometer (S8 = 6, 7)	177
5.4.7	APSt (All Preset) Reset to factory setting	178
5.5	CPU self-diagnostics	179
<b>6</b>	<b>Commissioning</b>	<b>181</b>
6.1	Adapting the direction of control action to the controlled system	181
6.2	Setting of actuating time in K-controllers (S2 = 0)	183
6.3	Adaptation of the S-controller to the actuating drive	183
6.4	Setting the filter and the response threshold	185
6.5	Automatic setting of control parameters by the adaptation method	186
6.6	Manual setting of the control parameters without knowledge of the plant behavior	189
6.7	Manual setting of the control parameters after the transient function	191
<b>7</b>	<b>Application examples for configuring the controller</b>	<b>193</b>
7.1	General	193
7.2	Working with different setpoints	195
7.3	Configuration examples	199
7.4	Configuring tool, forms	216
<b>8</b>	<b>Maintenance</b>	<b>223</b>
8.1	General information and handling	223
8.2	Exchanging components	224
8.3	LED-test and software version	226
8.4	Spare parts list	227
8.5	Ordering data	228
<b>9</b>	<b>General explanation of abbreviations for SIPART DR</b>	<b>229</b>
	<b>Index</b>	<b>235</b>



# 1 General Part – Fundamental control technology terms

## ● Control loop

The function of a closed-loop control is to bring the output variable  $x$  of a controlled system to a predefined value and to retain this value even under the influence of disturbance variables  $z$ . The controlled variable  $x$  is compared with the command variable  $w$ . The resulting system deviation  $x_d = w - x$  is processed in the controller to the manipulated variable  $y$  which acts on the controlled system.

The controlled variable  $x$  is measured cyclically in a digital control.

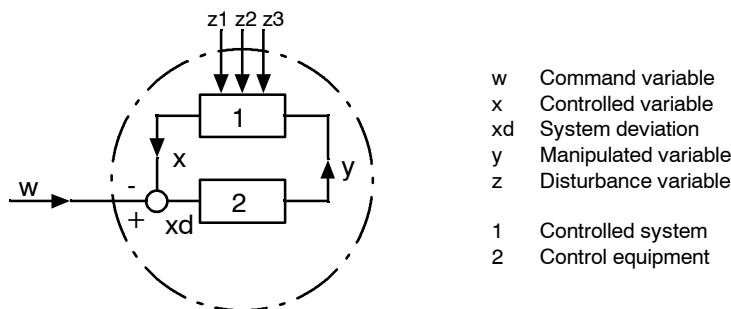

Figure 1-1 Function diagram of control loop

## ● Sensors and transmitters

The controlled variable can be any physical variable. Frequently controlled variables in process engineering are pressure, temperature, level and flow.

In most process engineering applications, the process variables are measured using sensors and transmitters with a standardized signal output (0 to 20 mA or 4 to 20 mA). The standardized signal can be connected to several process process devices (loop between e.g. recorder/indicator/controller). Temperature sensors such as resistance thermometers or thermocouples, as well as resistance transmitters, can be connected directly to the controller using appropriate input cards (options).

## ● Final control elements and actuators

In process engineering applications, the manipulated variable  $y$  primarily acts on the controlled system via a valve, a butterfly valve or another mechanical means of adjustment. Three types of drive are possible for actuating such final control elements:

- Pneumatic actuators with compressed air as the auxiliary energy and electropneumatic signal converters or electropneumatic positioners. These have a proportional action and are driven by continuous controllers.
- Electric actuators, consisting of an electric motor and gear unit. These have an integral action and are driven by three-position step controllers. Electric actuators are also possible with an integrated (series-connected) positioner and then have a proportional action and can be driven by continuous controllers.

- Hydraulic actuators with electric oil pump and electrohydraulic positioner. These have a proportional action and are also driven by continuous controllers. These types of actuators can be used to implement continuous controls.
- Temperature control loops with direct electric or gas heating and/or cooling systems are driven by two-position controllers (on/off controllers). The two-position controllers with the heating or cooling medium via relays, external contactors or thyristor controllers. The manipulated variable  $y$  is the on/off ratio. These are referred to as discontinuous controls.

### ● Controllers and control response

The controlled variable  $x$  is compared with the command variable  $w$  in the input circuit of the controller, and the system deviation  $x_d$  is determined. This is processed with or without a time response into the output signal. The output signal of the amplifier can directly represent the manipulated variable  $y$  if e.g. proportional-action final control elements are to be driven by it.

In the case of electric actuators, the manipulated variable is produced by the actuator. The required positioning increments are derived from the controller output as a pulse-width-modulated signal by conversion.

Depending on the design of this circuit, the controller has a proportional action (P), a proportional-plus-derivative action (PD), a proportional-plus-integral action (PI) or a proportional-plus-integral-plus-derivative action (PID).

### ● Step function

If a step function is applied to the controller input, a step-forced response results at the output of the controller in accordance with its time response.

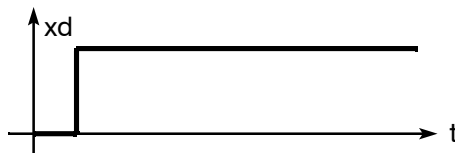

Figure 1-2 Step function

### ● P controller, step-forced response

Characteristic of the P controller are the proportional gain  $K_p$  and the working point  $y_0$ . The working point is defined as the value of the output signal at which the system deviation is zero. If disturbance variables are present, a steady-state deviation may result depending on  $y_0$ .

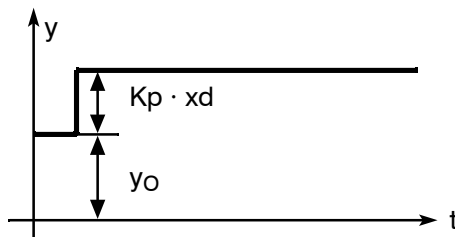

Figure 1-3 Step-forced response of P controller

- **PD controller, step-forced response**

In the case of the PD controller, the decaying D component is superimposed on the P component. The D component depends on the derivative action gain  $V_v$  and the derivative action time  $T_v$ .

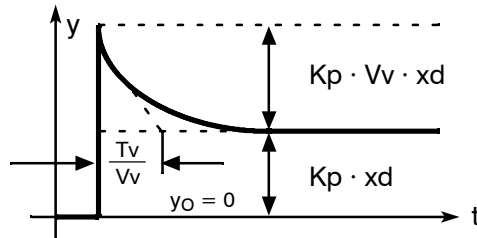

Figure 1-4 Step-forced response of PD controller

- **PI controller, step-forced response**

In contrast to the P controller, a steady-state deviation is prevented in the PI controller by the integral component.

A characteristic of the integral component is the integral action time  $T_n$ .

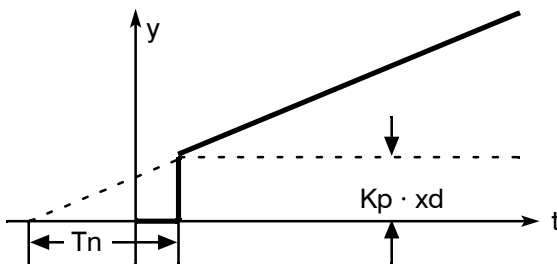

Figure 1-5 Step-forced response of PI controller

- **PID controller, step-forced response**

The PID controller results in improvement of the dynamic control quality as a result of the additional application of a D component.

Refer to the PD and PI controllers.

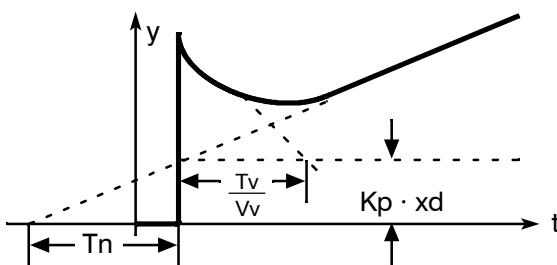

Figure 1-6 Step-forced response of PID controller

● **Controller output signal**

The controller output signal must be adapted to the final control element. The following must be used according to the type of drive/final control element:

Type of drive/actuator	Controller output signal
Electric actuators	Three-position step controllers
Pneumatic and hydraulic actuators	Continuous controllers
Direct heaters/coolers	Two-position controllers

● **Three-position step controller with internal feedback**

The three-position step controller switches the electric motor of the actuator to clockwise, stop or counterclockwise by means of relays or semiconductor switches. The rate of adjustment of the actuator can be influenced using different switch-on/pause ratios.

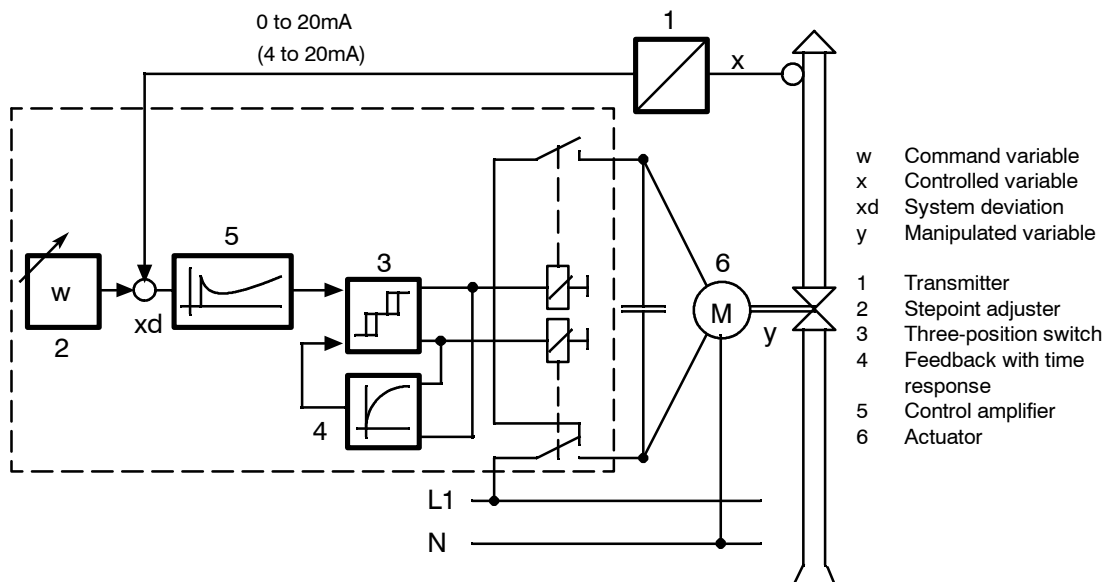

Figure 1-7 Function diagram of three-position step controller

The output response to the three-position amplifier in conjunction with the integral-action actuator permits a “continuous” manipulated variable taking into account the response threshold.

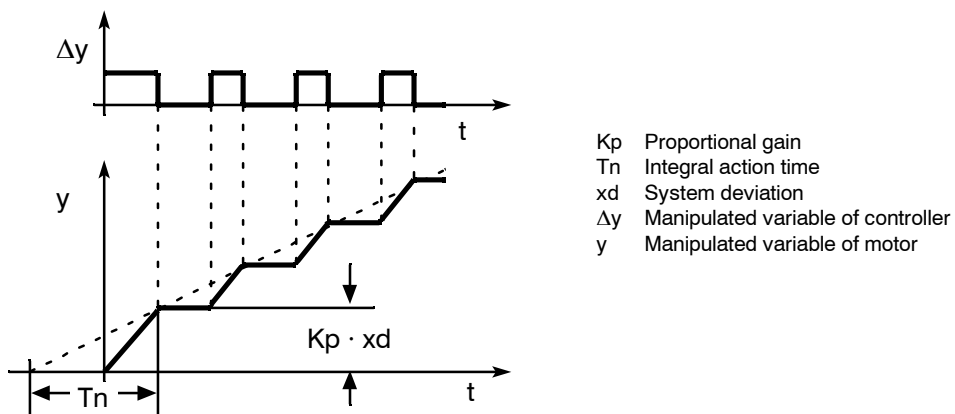

Figure 1-8 Transient function and parameters of the three-position step controller

• **Continuous controller**

The controller output 0 to 20 mA or 4 to 20 mA acts on the final control element via an electropneumatic signal converter or an electropneumatic positioner.

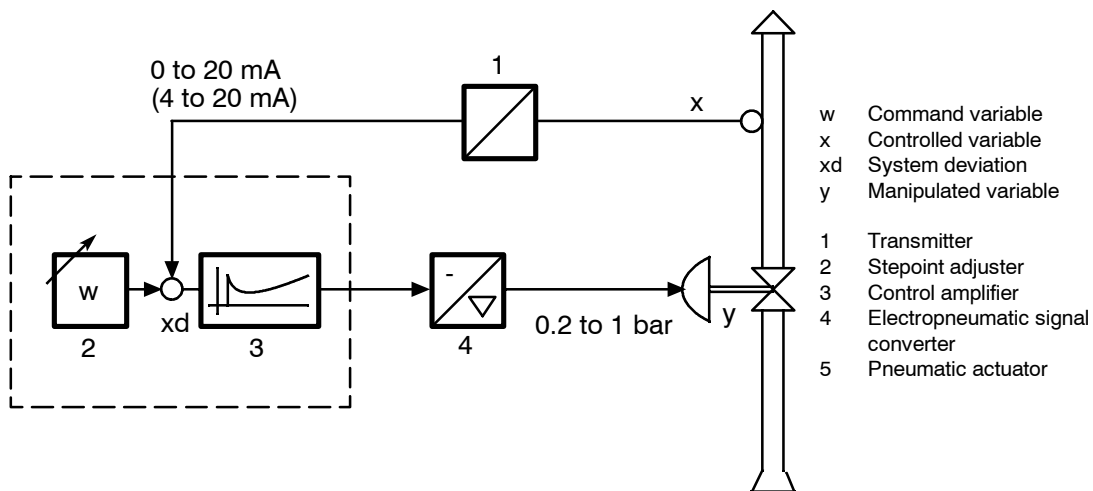

Figure 1-9 Function diagram of continuous controller

This type of controller is preferentially used in the chemical industry.

● **Two-position controller**

The two-position controller (or three-position controller for heating/cooling) is used to activate relays, contactors or thyristor switches for electric heating or cooling.

- **Two-position controller without feedback**

In the simplest version without feedback, two-position controllers operate an on/off switch. The controllers output is switched if the controlled variable violates the upper or lower limits of the switching hysteresis ( $x_1$  and  $x_2$ ). The controlled variable  $x$  is subject to permanent oscillation whose frequency and amplitude depend on the delay time of the system and the switching hysteresis of the controller.

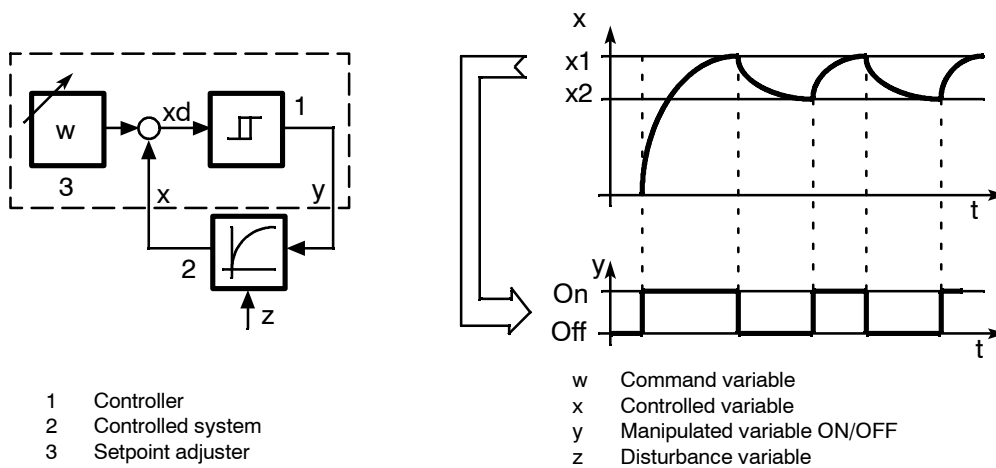

Figure 1-10 a) Function diagram

b) Switching output and response of controlled variable

- **Two-position controller with feedback**

In modern two-position controllers with feedback – such as the SIPART DR21 – the switching response is determined by the period, the system deviation and the parameters. The period  $T$  is set as a fixed value in the controller. The system deviation  $x_d$  in conjunction with the parameters  $K_p/T_n/T_v$  determines the duty factor (ON/OFF ratio) within the period. Thus the switching response of the controller is not only triggered by changes in the controlled variable; appropriate selection of the parameters results in a largely constant controlled variable  $x$ .

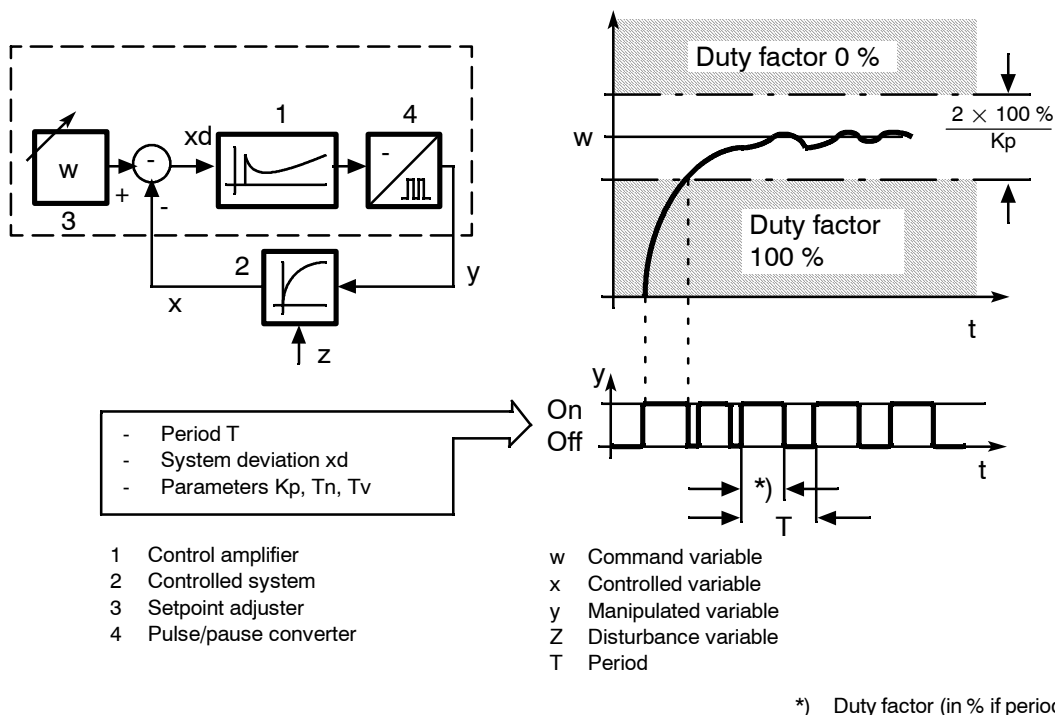

Figure 1-11 a) Function diagram

b) Switching output and response of controlled variable

Adjustment of the period (separately for heating/cooling) permits the controller to be adapted to the special type of heater or the cooling unit. A compromise has to be made between the control quality and the degree of wear.

Short period: Improved control quality, but increased wear on contact/heating valve. Prime use with electric heaters.

Long period: Low wear on contact/heating valve, but poorer control quality. Prime application with gas heaters or coolers.





## 2 Technical Description

### 2.1 Safety notes and scope of delivery



#### WARNING

When operating electrical equipment, certain parts of this equipment automatically carry dangerous voltages. Failure to observe these instructions could therefore lead to serious injury or material damage. Only properly trained and qualified personnel are allowed to work on this equipment. This personnel must be fully conversant with all the warnings and commissioning measures as described in this user's guide.

The perfect and safe operation of this equipment is conditional upon proper transport, proper storage, installation and assembly as well as on careful operation and commissioning.

#### ● Scope of delivery

When the controller is delivered the box also contains:

- 1 Controller as ordered
- 1 three-pin plug at 115/230 V AC or special plug at 24 V UC
- 2 Clamps, pluggable
- 1 Installation instructions, German/English, order no. C73000-M7474-C35
- 1 Quick Reference "Operating and Configuring", German/English, Order-No. C73000-B7474-C141
- 2 Adhesive labels "Power supply 115 V" (for 115/230 V-version).

#### ● Standard controllers

The following variants of the SIPART DR21 are available:

Order number:	Output stage	Power Supply
6DR2100-4	K/S-output	24 V UC
6DR2100-5	K/S-output	115/230 V AC, switchable

#### ● Options modules (signal converters)

Signal converters have separate ordering- and delivery items.

For handling reasons standard controllers and signal converters which were ordered at the same time may be delivered by separate mail.

#### ● Documentation

This user's guide is available in the following languages:

- English                   C73000-B7476-C143
- German                   C73000-B7400-C143

- **Subject to modifications**

The user's guide has been compiled with great care. However, it may be necessary, within the scope of product care, to make changes to the product and its operation without prior notice which are not contained in this user's guide. We are not liable for any costs ensuing for this reason.

## 2.2 Range of Application

- **Application**

The SIPART DR21 process controller is a digital instrument of the mid to upper performance class. It is used in control systems in process engineering for instance in the chemical and petrochemical industries, control- and power station engineering and in other fields of industry such as the food- and drink and tobacco industries.

The controller's great flexibility makes it suitable for use in simple or intermeshed control circuits. The wide setting range of the control parameters allow the SIPART DR21 to be used in process engineering both for fast (e.g. flow) and slow controlled systems (e.g. temperature). The controller determines the optimum control parameters independently on request without the user being expected to have any prior knowledge of how the control loop may respond. The applied adaptation procedure is suitable for systems with compensation and aperiodic transient behavior; Even greater dead times are taken into account. (Systems without compensation cannot be adapted by this method.)

- **Controlling tasks**

The input structure of the SIPART DR21 controller can be changed by configuring in such a way that the following controlling tasks can be solved.

- Fixed value controls, even with disturbance variables applied at the input
- Three-component controls
- Control circuits with up to two internal setpoints
- Follow-up-/synchronization controls
- Disturbance variables applied at the output
- Computer-controlled circuits in SPC- or DDC-operation
- Ratio controls with fixed or manipulated variables

SIPART DR21 can also be configured as a control unit, manual control unit, process display or resolver transmitter.

The SIPART DR21 controller can be used as a continuous controller with output 0/4 to 20 mA, as a stepper controller with a built-in relay for controlling motorized drives or as a two-position controller for heating/cooling systems.

Overlaid control functions or status- and alarm messages are possible through digital inputs- and outputs.

## 2.3 Features

- **General**

Up to four signal converters can be added to the already generously and extensively equipped, fully functional standard controller to expand the range of application by plugging them into the slots at the back of the closed device.

SIPART DR21 offers the following features:

- **Analog inputs**

Two analog inputs for current 0/4 to 20 mA, without potential isolation

The SIPART DR21 controller can be expanded to a total of 4 analog inputs with signal converters.

The following signal converters are available:

	Use as (on)	Possible signal generators
UNI-module	AI3 (slot 1)	TC/RTD/R/mV, with adapter plug also mA or V, electrically isolated, permissible common mode voltage 50 V.
U/I-module	AI3 (slot 1) AI4 (slot 2)	0/4 to 20 mA, 0/2 to 10 V, 0/0.2 V to 1 V Electronic potential isolation, permissible common mode voltage 10 V.
R-module	AI3 (slot 1) AI4 (slot 2)	Resistance potentiometer

In addition, the modules from the previous program (thermocouple/mV and Pt100) can be used (see SIPART DR20 user's guide for wiring).

- **Output structure**

The SIPART DR21 controller has a y-analog output (manipulated variable) with a current signal of 0/4 to 20 mA and a switching output with two built-in relays which are interlocked. The relay lock can be released for a universal digital output. The relays are designed for AC 250 V, a spark quenching combination for wiring with contactors is provided.

The SIPART DR21 can be configured to operate as a continuous controller, a stepper controller for motorized drives or as a two-position controller.

When used as S-controllers, the analog output can be used for outputting x, w or xd for example.



---

### **WARNING**

The relays are designed for a maximum switching voltage of AC 250 V/8 A in overvoltage class III and degree of contamination 2 according to DIN EN 61010 Part 1.

The same applies for the air- and creep lines on the circuit board.

Resonance increases up to three times the rated operating voltage may occur when phase shift motors are controlled. These voltages are available at the open relay contact. Therefore such motors may only be controlled under observance of the technical data and the pertinent safety conditions via isolated switching elements.

---

- **Voltage output**

A voltage output L+ for feeding two-wire-transmitters or contacts for digital inputs.

- **Slots for options**

Four rear slots can be used for functional expansions. The options modules are slot coded so that wrong installation is largely ruled out.

Slot assignment, see figure 2-2 Rear view, page 25.

- **Power supply unit**

The power supply unit is designed for the following voltages depending on the standard controller:

- 230 V/115 V AC, switchable by plug-in jumpers in the instrument.
- 24 V UC

- **Digital inputs**

Two digital inputs, potential-bound

It can be upgraded to four or seven potential-bound digital inputs with signal converters.

The digital inputs can be assigned to the following controller-internal switching signals.

bLb	<i>Blocking operation</i> Blocking the entire instrument operation and configuring. Exception: Switching the w/x-digital display
bLS	<i>Blocking structuring</i> With this signal the controller only allows switching to the online-parameterization levels outside process operation. In this way the parameters for adapting the instrument to the process and the necessary settings for adaptation can be selected. Structuring is blocked.
bLPS	<i>Blocking parameterization and structuring</i> The entire configuring of the instrument is blocked, this means the parameterization as well. Only the normal process operation according to the preselected controller type is permitted.
CB	<i>Computer-standby</i> Depending on the controller type, this digital signal together with the Internal/External key causes either switching in the setpoint range. In DDC-controllers, DDC-operation begins.
He	<i>Manual external</i> This signal blocks the output of the controller and enables direct manual adjustment of the manipulated variable on the front control panel.
N	<i>Tracking</i> With this signal the output of the K-controller and the three-position-step controller with external position feedback is tracked to the tracking signal $y_N$ .
Si	<i>Safety operation</i> The output of the K-controller or the three-position-stepper controller with external position feedback accepts the parameterized safety value. In three-position-stepper controllers with internal position feedback, the manipulated variable runs defined to 0 or 100 %.
P	<i>P-operation</i> Switching from PI (PID) to P (PD)-controller (i.e. switch off the I-part) This function simplifies automatic start-up of control circuits.
$\bar{tS}$	<i>Switching off the setpoint ramp time</i>
tSH	Hold on setpoint change (setpoint ramp)
+yBL / -yBL	<i>Direction-dependent blocking of the manipulated variable</i> Direction-dependent limiting of the manipulated variable by external signals, e.g. from the limit switches of the actuating drives. This limiting is effective in every operating mode.

● **Digital outputs**

Two digital outputs, active, potential-bound.  
It can be upgraded to four or six digital outputs with signal converters.  
The digital outputs are loadable up to 30 mA per output for direct tripping of relays.  
The digital outputs can also be used for the variable output, the relay outputs are then free for any digital signal output.  
The following controller-internal switching signals can be assigned to the digital outputs or relays.

- $\overline{RB}$       *Computer standby*  
Message that the controller can be switched to the external setpoint by the CB-signal.
- $\overline{RC}$       *Computer operation*  
Message that the controller is presently in computer operation or that it has been switched over to the external setpoint by the CB-signal.
- H            *Manual mode*  
Message that the controller has been switched over to manual mode with the Manual/Automatic key.
- Nw          *Tracking operation active*  
Message that the controller is in tracking operation.
- A1 bis A4    *Alarm output Alarm 1 to Alarm 4*
- MUF        *group alarm transmitter fault*  
The instruments's analog input signals can be monitored for exceeding of the measuring-range. This signal gives a group alarm if an error is detected.
- $\pm \Delta w$     *Output of switching signals for setpoint adjustment*  
This function is only active when the controller is structured as a control unit (S1=4).
- $\pm \Delta y$     *Output of the incremental y-adjustment*  
Assignment is only possible on DO1, 2, 7 or 8 (S57).

The following signal converters are available for extending the digital inputs and outputs:

	<b>Use on</b>	<b>Description</b>
4 x DO/2 x DI	Slot 3	4 binary outputs 24 V 2 binary inputs 24 V
5 x DI	Slot 3	5 binary inputs 24 V
2 x relays	Slot 3	2 relay outputs 35 V

● **Serial interface**

An interface can be retrofitted with signal converters for RS 232/RS 485 or PROFIBUS DP.

- **Others**

Further functions are also possible. Examples:

	Meaning	see chapter
Adaptation-procedure	Automatic determining of the controller parameters by means of a robust adaptation method which also considerably simplifies commissioning of even critical controlled systems.	Configuring level AdAP; 3.9 (page 113) and 5.4.3 (page 156)
adaptive filter for xd	Filter which dampens amplitude-dependent interference, the value of the dampening is adapted automatically.	onPA-Parameter tF 3.10.1 (pg. 115) and 5.4.2 (page 155)
Setpoint ramp	Prevents the setpoint or nominal ratio being changed too fast. The desired adjustment speed can be set. The time for the change is set from 0 to 100 % here. The setpoint ramp is not active at x-tracking and digital signal tS̄.	oFPA-Parameter tS̄; 3.4.1 (pg. 55) and 5.4.4 (pg. 163)
Filter for all inputs	A 1st order filter can be connected to every analog input.	onPA-Parameters t1 to t4; 3.2 (pg. 47) and 5.4.2 (pg. 155)
Root extractor for all controller inputs	A root extractor can be connected before every analog input.	Structure switches S11 to S14; 3.2 (pg. 47) and 5.4.5 (pg. 165)
Linearizer for an input variable	A linearizer with 13 (equidistant) support points and parabolic approximation can be assigned to one of the analog inputs AI1 to AI4 or to the controlled variable x1.	Structure switch S21; 3.10.4 (pg. 118) and 5.4.5 (pg. 165)
Initialization of the display x/w	The controlled variable x and the command variable w can be displayed in physical values.	oFPA-Parameter dA, dE; 3.4.1 (pg. 55) and 5.4.4 (pg. 163)
Limits for the setpoint w	The setpoint can be limited anywhere within the selected measuring range.	oFPA-Parameter SA, SE; 3.4.1 (pg. 55) and 5.4.4 (pg. 163)
Limits of the manipulated variable y	The manipulated variable y can be limited within the setting range -10% and +110 %. (Not in S-controllers with internal feedback)	onPA-Parameter YA, YE; 3.5 (pg. 91) and 5.4.2 (pg. 155)
x-Tracking	The setpoint w is tracked to the controlled variable x in manual-, tracking- and DDC-operation as well as at the safety setpoint.	Structure switch S43; 3.4.1 (pg. 55) and 5.4.5 (pg. 165)
Limit value alarms	Any controller-internal variables or inputs can be monitored for limit values. The output is by way of alarms A1 to A4.	Structure switches S76 and S77; 3.10.3 (pg. 117) and 5.4.5 (pg. 165)
Transmitter monitoring	All or specific analog inputs can be monitored for dropping below- or- exceeding the range. In the event of a fault, the four-digit digital display outputs a message selectively for every input. A system fault can be output via the digital output MUF.	Structure switches S4 to S7, S66; 3.2 (pg. 47) and 5.4.5 (pg. 165)
Adaptation of the direction of action	SIPART DR21 operates with normal direction in the factory setting. The direction of the controller can be changed for reversing systems.	Structure switch S46; 3.5 (pg. 91) and 5.4.5 (pg. 165)
Restart conditions	After mains recovery the controller starts automatically with the structured operating modes, setpoints and manipulated variables.	Structure switch S82; 3.10.5 (pg. 120) and 5.4.5 (pg. 165)

## 2.4 Design

### ● Standard controller

The process controller has a modular structure and is therefore maintenance friendly and easy to convert- and retrofit.

The standard controller consists of

- the front module with the control- and display elements
- the backplane module with the power supply unit
- the plastic housing with four slots for optional modules

### ● Front module

The front module accommodates the control- and display elements, the CPU (Central Processing Unit) and the connectors for the backplane- and options modules.

It is operated by a membrane keyboard with IP64 degree of protection. The front design is based directly on the SIPART DR 20/22/24-controller-family with color coded assignment of the display- and control elements.

For better monitoring of the process, SIPART DR21 has user-friendly analog displays for the setpoint- and actual value display, a four-digit digital display which can be set for setpoint, actual value and alarms (depending on the controller setting), a two-digit digital display for the manipulated variable  $y$ , numerous control keys and indicator diodes for various status signals.

The tag plate and the scales for the analog displays are replaceable.

### ● Backplane module with power supply unit

The following signal connections are accessible through the backplane.

- 2 analog inputs AI1, AI2, potential-bound to GND, 0/4 to 20 mA
- 1 analog output AO, potential-bound to GND, 0/4 to 20 mA
- 2 digital outputs  $+ \Delta y$ ,  $- \Delta y$ , potential-free via relay contacts
- 2 digital inputs DI1, DI2, for 24V-logic, function can be set
- 2 digital outputs DO1, DO2, for 24V- logic, function and direction can be set
- 1 Voltage output L+ to the transmitter supply

The power supply is located in a die-cast housing on the backplane module. The heat loss is transferred to the back of the controller by cooling fins.

A DIN rail can be mounted for connecting a powerful coupling relay module.

The power supply unit is high powered and offers a total 200 mA current for:

- supplying the analog output (0/4 to 20 mA)
- Active digital outputs (up to 6 digital outputs)
- L+-output for supplying two-wire-transmitters
- supplying the interface module



### ● Connection technique

The power supply is connected

- for 230 V/115 V AC by a three-pin plug
- for 24 V UC by a special two-pin plug.

On the standard controller the field lines (signal cables) are connected to three functionally combined plug-in screw-type terminals.

The options modules for analog inputs and digital inputs- and outputs have their own terminals which are also designed as plug-in screw-type terminals.

The interface module is connected by its own plug.

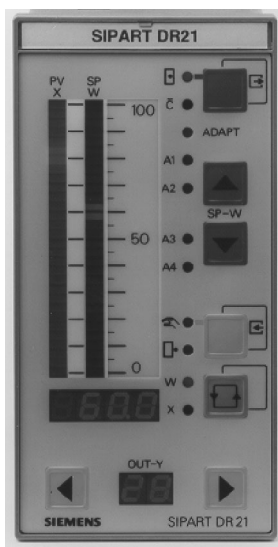
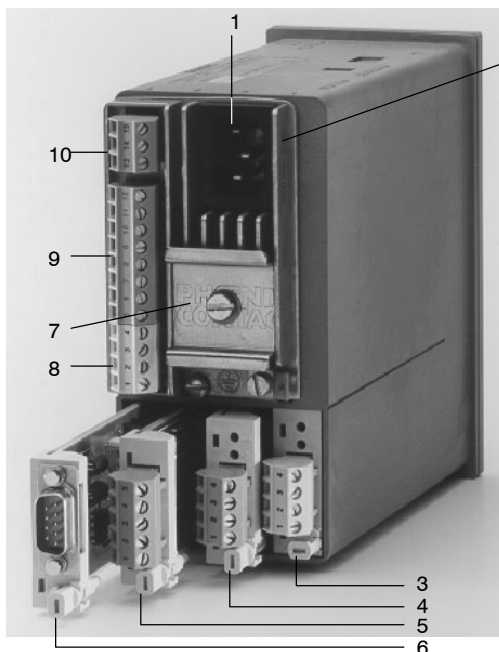

Figure 2-1 Front view



- |    |   |
|----|---|
| 1  | Mains plug  |
| 2  | Power supply unit   |
| 3  | Slot 1 AI3 (I/U, R, P, T)   |
| 4  | Slot 2 AI4 (I/U, R, P, T)   |
| 5  | Slot 3 4DO, 24 V or<br>2DO relay or<br>5DI                        |
| 6  | Slot 4 SES/PROFIBUS-DP  |
| 7  | DIN rail<br>(scope of delivery of the relay module)               |
| 8  | Terminal block 1<br>AI1 to AI2 (I)                                |
| 9  | Terminal block 2<br>AO1<br>DI1 to DI2<br>DO1 to DO2 24 V<br>L+; M |
| 10 | Terminal block 3<br>Digital outputs $\pm \Delta y$                |

Figure 2-2 Rear view

## 2.5 Function principle

### 2.5.1 Standard controller

- **General**

The SIPART DR21 controller operates on the basis of a modern, highly-integrated microcontroller in C-MOS-technology. A large number of functions for controlling processing plants are stored in the instrument's ROM. The user can adapt the controller to the task himself by configuring it.

- **Analog inputs AI1 and AI2.**

The analog inputs of the SIPART DR21 are designed for 0/4 to 20 mA input signals. The inputs have an input load resistance of 248  $\Omega$  and are potential-bound. The start value 0 mA or 4 mA is determined by the structure switches S4 and S5.

- **Outputs for the manipulated variable Y**

The standard controller has the following outputs

K-output: switchable between 0 or 4 to 20 mA, potential-bound (S56)  
S-output: two relays, NOC, interlocked in factory setting, built-in spark quenching designed for wiring with medium contactors. Other functions can be assigned to the relay outputs by configuration (structure switches S57 to S68), e.g. manipulated variable output  $\pm \Delta y$  in S-controllers.

- **Digital outputs DO1 and DO2**

The digital outputs are short-circuit-proof and can drive commercially available relays or the interface relays 6DR2804-8A/8B directly. Different functions can be assigned to the digital outputs by configuration (structure switches S57 to S68).

- **Digital inputs DI1 and DI2**

The inputs are designed in 24-V-logic and are potential-bound. The function is assigned to the input by configuration of the controller (structure switches S23 to S33).

- **CPU**

The microcontroller used has integrated AD- and DA-converters and watchdog-circuits for cycle monitoring. The processor operates with a 64k EPROM (on a socket and therefore replaceable) and a 1k RAM.

The SIPART DR21 program runs with a fixed cycle time of 100 ms. A process image is generated at the start of every routine. The analog- and digital inputs, the operation of the front keyboard and the process variables received by the serial interface are acquired or accepted. All calculations are made according to the stored functions with these input signals. Then output to the display elements, the analog outputs and the digital outputs and

storage of the calculated variables for transmission mode of the serial interface take place. In S-controllers, the program run is interrupted every 5 ms to be able to switch off the S-outputs for better resolution. The interface communication also runs in interrupt mode.

- **Power supply unit**

A cast, overload-protected mains transformer for 115 V or 230 V AC built into a heat sink or a primary clocked plug-in type power supply unit for 24 V UC built into a heat sink generates the secondary internal supply voltages +24 V, +5 V and  $U_{ref}$  from the power supply. The metal body rests on protective conductors (protection class I).

The power supply and internal supply voltages are isolated from each other by safe separation.

The internal supply voltages are function low voltages.

Since no other voltages are generated in the instrument, these statements apply to all field signal lines with the exception of relay connection lines (used standards see chapter 2.6 Technical data, page 34).

- **Configuring**

The controller has a large number of prepared functions for controlling processing plants. The user programs the instrument himself by selecting the desired functions or setting parameters by setting structure switches. The total functioning of the instrument is given by the combination of the individual structure switches or parameter settings. No programming knowledge is necessary (see Operation, chapter 5, page 149).

All settings are made without exception on the front operating panel of the SIPART DR21 or the serial interface.

The job-specific program written in this way is saved in the non-volatile user program memory.

The instrument is configured as a fixed value controller in the factory setting. This setting can be restored with the "APSt"-function at any time.

The following parameterization- and structuring modes are available for configuring the SIPART DR21 controller.

onPA	The transmission properties of the controller and with these the process course are determined with the <b>online-parameters</b> . They can be changed during control operation (online)
oFPA	The <b>offline-parameters</b> determine the basic functions such as display elements, limit values, safety values. The controller is blocked (offline) while they are being set, the last value of the manipulated variable is held.
StrS	The instrument structure, e.g. fixed value controller or follow-up controller is determined with the <b>structure switches</b> . The controller is blocked (offline) while they are being set, the last value of the manipulated variable is held.
APSt	The <b>all preset-function</b> restores the factory setting.

- (AdAP) In the **adaptation level** the output conditions for automatic adaptation of the controller parameters to the process is preset and adaptation started.
- (CAE3) The measuring range is set and fine adjustment made if necessary here for the **UNI-module**.  
The CAE3-menu is only displayed if it has been released in the structuring level (structure switch S6>3).

### 2.5.2 Option module

The following option modules are described in this chapter

6DR2800-8J	I/U-module
6DR2800-8R	R-module
6DR2800-8V	UNI-module
6DR2805-8A	reference point
6DR2805-8J	measuring range plug
6DR2801-8D	module with 2 DO (relay)
6DR2801-8E	module with 2 DI and 4 DO
6DR2801-8C	module with 5 DI
6DR2803-8P	serial interface PROFIBUS-DP
6DR2803-8C	serial interface RS 232/RS 485
6DR2804-8A	module with 4 DO relays
6DR2804-8B	module with 2 DO relays

#### 6DR2800-8J I/U-module

- **Input variables current 0/4 to 20 mA or voltage 0/0.2 to 1 V or 0/2 to 10 V**

The module's input amplifier is designed as a differentiating amplifier with shuntable gain for 0 to 1 V or 0 to 10 V input signal. For current input signals the  $49.9 \Omega$  0.1 % impedance is switched on by plug-in bridges on the module. The start value 0 mA or 4 mA or 0 V or 0.2 V (2 V) is defined by configuration in the standard controller. The differentiating amplifier is designed for common mode voltages up to 10 V and has a high common mode suppression. As a result it is possible to connect the current inputs in series as for electrical isolation when they have common ground. For voltage inputs this circuit technique makes it possible to suppress the voltage drops on the ground conductor by two-pole wiring on potential-bound voltage sources. We refer to an electronic potential isolation.

#### 6DR2800-8R R-module

- **Input for resistance- or current potentiometer**

Potentiometers with rated values of  $80 \Omega$  to  $1200 \Omega$  can be connected as resistance transmitters. A constant current of  $I_s = 5 \text{ mA}$  is fed to the potentiometer wiper. The wiper resistance is therefore not included in the measurement. Resistors are switched parallel to the potentiometer by settings on the module and a rough range selection made. Start of scale and – full scale are set with the two adjusting pots on the back of the module.

This fine adjustment can be made on the displays on the front module (if structured appropriately). For adjustment with a remote measuring instrument, the analog output can be assigned to the appropriate input.

The external wiring must be changed for resistance transmitters which cannot withstand the 5 mA wiper current or which have a rated resistance  $>1\text{ k}\Omega$ . The constant current is then not fed through the wiper but through the whole resistance network of the potentiometer. A voltage divider measurement is now made through the wiper. Coarse adjustment is made by a remote parallel resistor to the resistance potentiometer.

This module can also be used as a current input with adjustable range start and full scale. The load is  $49.9\ \Omega$  and is referenced to ground.

### 6DR2800-8V UNI-module

- **Direct connection of thermocouple- or Pt100-sensors, resistance- or mV-transmitters**

Measured value sensors such as thermocouples (TC), resistance thermometers Pt100 (RTD), resistance potentiometers (R) or voltage transmitters in the mV-range can be connected directly. The measuring variable is selected by configuring the controller in the StrS-level (structure switches S6, S8, S9 and S10), the measuring range and the other parameters are set in the CAE3-menu. The sensor-specific characteristics (linearization) for thermocouples and Pt100-resistance thermometers are stored in the controller's program memory and are automatically taken into account. No settings need to be made on the module itself.

The signal lines are connected by a plug terminal block with screw-type terminals. When using thermocouples with internal reference point, this terminal block must be replaced by the terminal 6DR2805-8A. With the measuring range plug 6DR2805-8J in place of the terminal block, the measuring range of the direct input (0/20 to 100 mV) can be extended to 0/2 up to 10 V or 0/4 up to 20 mA.

The UNI-module operates with an AD-converter with 18 bit resolution. The measuring inputs and ground of the standard controller are electrically isolated with a permissible common mode voltage of 50 V UC.

The UNI-module can only be used at slot 1 (AI3).

### 6DR2805-8A Reference point

- **Terminal with internal reference point for thermocouples**

This terminal is used in connection with the UNI-module for temperature measuring with thermocouples at an internal reference point. It consists of a temperature sensor which is pre-assembled on a terminal block and plated to avoid mechanical damage.

---

### 6DR2805-8J Measuring range plug

- **Measuring range plug for current 0/4 to 20 mA or voltage 0/2 to 10 V**

The measuring range plug is used in connection with the UNI-module to measure current- or voltage. The input variable is reduced to a signal range of 0/20 to 100 mV by a voltage divider or shunt resistors in the measuring range plug.

Wiper resistors with 250  $\Omega$  or 50  $\Omega$  are available optionally at 2 different terminals for 0/4 to 20 mA-signals.

The electrical isolation of the UNI-module is retained even when the measuring range plug is used.

### 6DR2801-8D 2 DO relays

- Digital output module with 2 relay contacts

To convert 2 digital outputs to relay contacts up to 35 V UC.

This module is equipped with 2 relays whose switching contacts have potential free outputs. The RC-combinations of the spark quenching elements are respectively parallel to the rest- and working contacts.

In AC-consumers with low power the current flowing through the capacitor of the spark quenching element when the contact is open may interfere (e.g. the hold current of some switching elements is not exceeded). In this case the capacitors (1  $\mu$ F) must be removed and replaced with low capacitance capacitors.

The 68 V suppressor diodes parallel to the capacitors act additionally to reduce the induced voltage.

---

#### CAUTION

The relays used on the digital output module are designed for a maximum rating up to UC 35 V. The same applies for the air- and creep lines on the circuit board. Higher voltages may therefore only be switched through appropriately approved series connected circuit elements under observance of the technical data and the pertinent safety regulations.

---

### 6DR2801-8E 2 DI and 4 DO

- Digital signal module with two digital inputs and 4 digital outputs

The module serves to extend the digital inputs and digital outputs already existing in the standard controller.

The inputs are designed in 24-V-logic and are potential-bound. The functions are assigned to the inputs- and outputs by configuration of the controller. (Structure switches S23 to S33, S58 to S68).

The digital outputs are short-circuit-proof and can drive commercially available relays or the interface relays 6DR2804-8A/8B directly.

**6DR2801-8C 5 DI**

- Digital input module with 5 digital inputs

The module serves to extend the digital inputs already existing in the standard controller.

The inputs are designed in 24-V-logic and are potential-bound. The function is assigned to the input by configuration of the controller (structure switches S23 to S33).

**6DR2803-8P serial interface PROFIBUS-DP**

The 6DR2803-8P module is a PROFIBUS-DP-interface module with RS-485-driver and electrical isolation from the instrument. It operates as an intelligent converter module and adapts the private SIPART- to the open PROFIBUS-DP-protocol.

This options card can be used in all SIPART-DR-instruments in slot 4. The following settings must be made with the appropriate structure switches for the serial interfaces.

- Interface on
- Even parity
- LRC without
- Baud rate 9600
- Parameters/process values writable (as desired)
- Station number of choice 0 to 125

Make sure that the station number is not assigned double on the bus. The PROFIBUS-module serves to connect the SIPART-controllers to a master system for control and monitoring. In addition the parameters and structure switches of the controller can be read and written. Up to 32 process variables can be selected and read out cyclically by configuration of the PROFIBUS-module.

The process data are read out of the controller in a polling procedure with an update time <300 ms. If the master write process data to the slave, these become active after a maximum of one controller cycle.

A technical description including the controller-base-file (\*.GSD) is available in Internet for creating a master-slave-linking software for interpreting the identifications and useful data from and to the SIPART-controller.

Internet address: [www.fielddevices.com](http://www.fielddevices.com) [Edition: 05.2000]

The SIPART S5 DP and SIPART S7 DP programs are offered for DP-masters SIMATIC S5 and S7.

## 6DR2803-8C Serial interface RS 232/RS 485

### • Serial interface for RS 232 or RS 485 with electrical isolation

Can be used in slot 4, the structure switches S84 to S91 must be set for the transmission procedure.

For connecting the controller SIPART DR21 to a master system for control and monitoring. All process variables can be sent, the external setpoint, tracking variable, operating states, parameters and structurings sent and received via the interface.

Interface communication can take place:

- RS 232 as a point-to-point connection
- SIPART Bus The SIPART bus driver is no longer available. Therefore, please realize multi-couplings via RS 485 or PROFIBUS DP.
- RS 485 As a serial data bus with up to 32 users.

The interface module 6DR2803-8C offers electrical isolation between Rxd/Txd and the controller. Switching can be performed between RS 232 and RS 485 with a plug-in bridge.

A detailed technical description of the data communication for creating a linking software is available in Internet under [www.fielddevices.com](http://www.fielddevices.com) [Edition 05.2000].

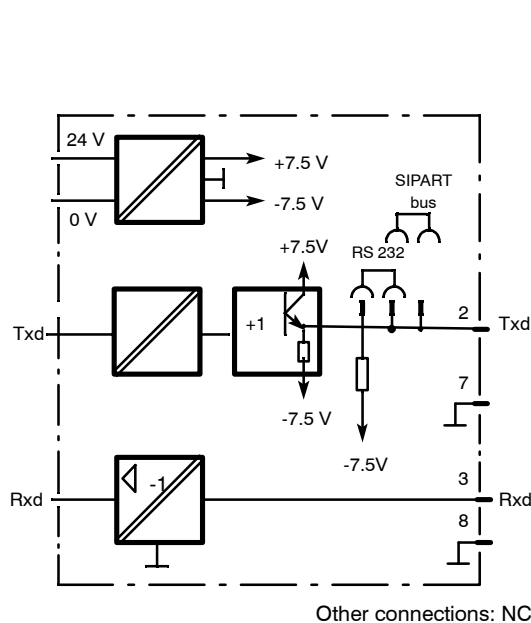

Figure 2-3 Block diagram serial interface in RS 232/SIPART BUS

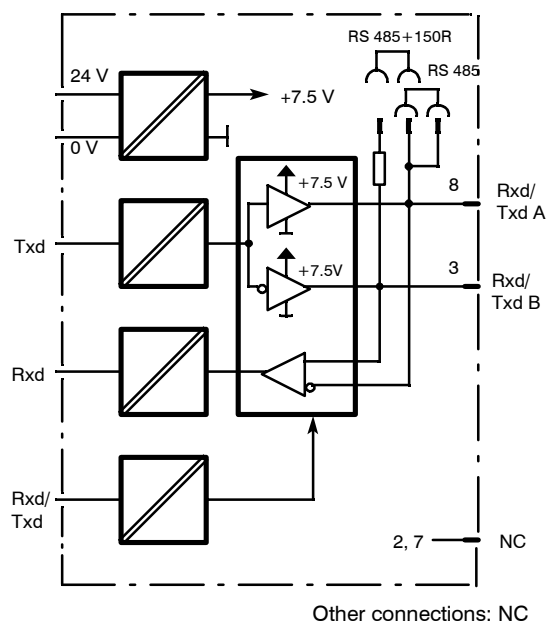

Figure 2-4 Block diagram serial interface at Interface RS 485



**6DR2804-8A module with 4 DO-relays**  
**6DR2804-8B module with 2 DO-relays**

- Coupling relay module with 2 or 4 relays

To convert 2 or 4 binary outputs to relay contacts up to 230 V UC.

The relays can be snapped onto a mounting rail on the back of the controller. The mounting rail is delivered with the coupling relay module.

One or two relay modules are installed per version. Each of these modules consists of two relays with quench diodes parallel to the control winding. Every relay has a switching contact with spark quenching in both switching branches. In AC-consumers with a very low power, the current flowing (e.g. hold current in contactors) through the spark quenching capacitor (33nF) when the contact is open interferes. In this case they should be replaced by capacitors of the same construction type, voltage strength and lower value.

The switching contact is fed to the plug terminals with 3 poles so that the rest and working circuits can be switched. The relays can be controlled directly from the controller's digital outputs by external wiring.

**CAUTION**

The relays used on the interface relay module are designed for a maximum rating of AC 250 V in overvoltage class III and contamination factor 2 according to DIN EN 61010 Part 1.

The same applies for the air- and creep lines on the circuit board.

Resonance increases up to double the rated operating voltage may occur when phase shift motors are controlled. These voltages are available at the open relay contact. Therefore such motors may only be controlled under observance of the technical data and the pertinent safety conditions via approved switching elements.

---

## 2.6 Technical Data

### 2.6.1 General data

Installation position	any
Climate class to IEC 721	
Part 3-1 Storage 1k2	-25 to +75 °C
Part 3-2 Transport 2k2	-25 to +75 °C
Part 3-3 Operation 3k3	0 to +50 °C
Type of protection according to EN 60529	
Front	IP64
Housing	IP30
Connections	IP20
Housing design	
• Electrical safety	
- acc. to DIN EN 61 010 part 1,	
- Protection class I acc. to IEC 536	
- Safe disconnection between mains connection and field signals	
- Air and creep lines, unless specified otherwise, for overvoltage class III and degree of contamination 2	
• EC declaration of conformity number 1243.00-05/01	
• CE mark of conformity regarding:	
- EMC regulation 89/336/EWG and	
- LV regulation 73/23/EWG	
has been fulfilled without restriction	
• Spurious emission, interference immunity according to EN 61 326, NAMUR NE21 8/98	
The following licenses and identification nos. are available for the SIPART DR21 controllers:	
• Certification of the "Germanischer Lloyd"	
Certificate No. 97 974-96 HH	
• Certificate of the "DIN CERTCO, Berlin",	
license as a temperature control and limiting device for heat generators, certification of conformity with DIN 3440:1984-07,	
register number: <b>TR 10692000 S</b>	
• TÜV-certificate of the awarding of a component identification for water level controllers, award according to the VdTÜV information brochure "Water level 100" and "Water level100/1",	
component identification no. <b>TÜV.WRS(WR).00-378K</b>	
Weight, standard controller	approx. 1.2 kg
Color	
Front module frame	RAL 7037
Front surface	RAL 7035
Material	
Housing, front frame	Polycarbonate, glass-fiber reinforced
Front foil	Polyester
Backplanes, modules	Polybutylenterephthalate

Connection technique

Power Supply  
115/230 V AC  
24 V UC  
Field signals

Three-pin plug IEC320/V DIN 49457A  
Special 2-pin plug  
Plug-in terminals for 1.5 mm<sup>2</sup> AWG 14

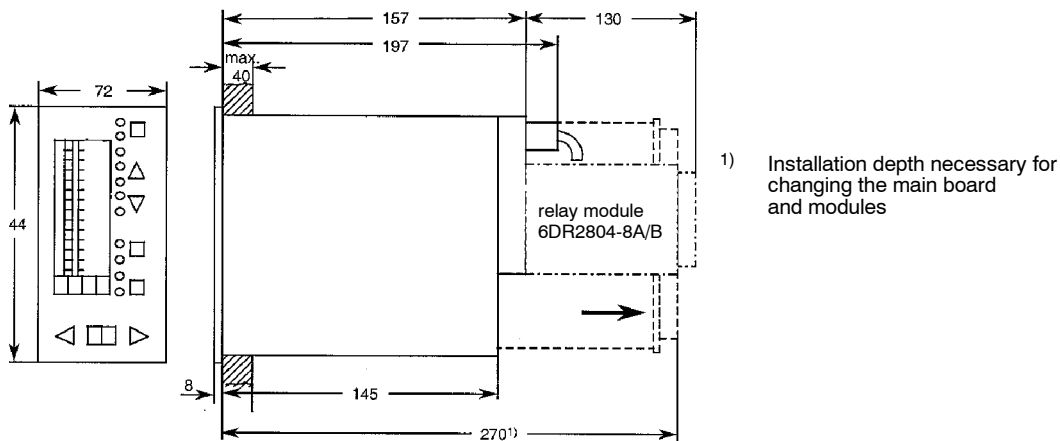

Figure 2-5 Dimensions SIPART DR21, dimensions in mm

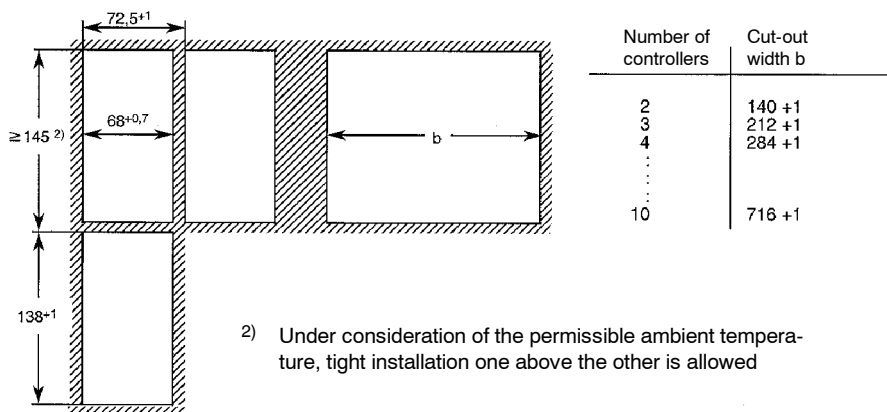

Figure 2-6 Panel cut-outs, dimensions in mm

## 2.6.2 Standard controller

### Power Supply

Rated voltage	230 V AC	115 V AC	24 V UC	
	switchable			
Operating voltage range	195 to 264 V AC	97 to 132 V AC	20 to 28 V AC	20 to 35 V DC <sup>1)</sup>
Frequency range	48 to 63 Hz			---
External current $I_{Ext}^{2)}$	200 mA			
Power consumption				
Standard controller without options without $I_{Ext}$ active power/apparent power (capacitive)	5 W/9 VA	5 W/9 VA	4 W/6 VA	4 W
Standard controller with options without $I_{Ext}$ active power/apparent power (capacitive)	11 W/15 VA	11 W/15 VA	8.5 W/12 VA	8.5 W
Standard controller with options with $I_{Ext}$ active power/apparent power (capacitive)	15 W/19 VA	15 W/19 VA	12 W/17 VA	12 W
Permissible voltage breaks based on $0.85 U_N$ and max. load Time <sup>3)</sup>	≤ 20 ms	≤ 20 ms	≤ 20 ms	≤ 20 ms

1) including harmonic

2) current transmitted from L+, DO, AO to external loads

3) The load voltages of the AO are reduced hereby to 13 V, L+ to 15 V and the DO to 14 V

Table 2-1 Power supply standard controller

### Analog inputs AI1 to AI2

#### Current

Rated signal range	0/4 to 20 mA		
Modulation range	-0.1 to 22 mA		
Input resistance			
Difference (load)	248 Ω ± 1 %		
Filter time constant	10 ms		
Zero error	see AD-converter		
Full scale error	see AD-converter		
Linearity error	see AD-converter		
Temperature influence	see AD-converter		
Static destruction limit	± 40 mA		
Parameterizable transmitter fault message			
AI1/2	0 mA to 20 mA	≤ -0.5 %;	≥ 106.25 %
	4 mA to 20 mA	≤ -2.5 %;	≥ 106.25 %
AI3/4	0/4 mA to 20 mA	≤ -2.5 %;	≥ 106.25 %

**Digital inputs DI1, DI2**

Signal status 0	$\leq 4.5 \text{ V}$ or open
Signal status 1	$\geq 13 \text{ V}$
Input resistance	$\geq 27 \text{ k}\Omega$
Static destruction limit	$\pm 35 \text{ V}$

**NOTE**

All error specifications refer to the rated signal range

**Analog outputs AO**

Rated signal range (0 to 100 %)	0 to 20 mA or 4 to 20 mA
Modulation range	0 to 20.5 mA or 3.8 to 20.5 mA
Load voltage	from $-1$ to $18 \text{ V}$
No-load voltage	$\leq 26 \text{ V}$
Inductive load	$\leq 0.1 \text{ H}$
Time constant	$10 \text{ ms}$
Residual ripple 900 Hz	$\leq 0.2 \%$
Resolution	$\leq 0.1 \%$
Load dependence	$\leq 0.1 \%$
Zero error	$\leq 0.3 \%$ <sup>1)</sup>
Full scale error	$\leq 0.3 \%$ <sup>1)</sup>
Linearity	$\leq 0.05 \%$
Temperature influence	
Zero point	$\leq 0.1 \%/10 \text{ K}$
Full scale	$\leq 0.1 \%/10 \text{ K}$
Static destruction limit	$-1$ to $35 \text{ V}$

**S-output (relay 230 V) DO7 and DO8**

- <b>Contact material</b>	Ag / Ni	
- <b>Contact load capacity</b>		
Switching voltage		
AC	$\leq 250 \text{ V}$	
DC	$\leq 250 \text{ V}$	
Switching current	<u>Contacts</u>	<u>Contacts</u>
	<u>locked</u>	<u>unlocked</u>
AC	$\leq 8 \text{ A}$	$\leq 2.5 \text{ A}$
DC	$\leq 8 \text{ A}$	$\leq 2.5 \text{ A}$
Rating		
AC	$\leq 1250 \text{ VA}$	
DC	$\leq 30 \text{ W}$ at $250 \text{ V}$	
	$\leq 100 \text{ W}$ at $24 \text{ V}$	

<sup>1)</sup> Applies for interference acc. to IEC 801-3 to  $3 \text{ V/m}$ , with  $10 \text{ V/m}$  at  $290$  to  $310 \text{ MHz}$   $\leq 4.3 \%$

Service life	
mechanical	$2 \times 10^7$ switching cycles
230 V AC 8A electrical ohmic	$10^5$ switching cycles
Spark quenching element	Series circuit 22 nF/220 $\Omega$ parallel to it varistor 420 V <sub>rms</sub>

**Digital outputs DO1 to DO2 (with wired-or diodes)**

Signal status 0	$\leq 1.5$ V
Signal status 1	+19 V to 26 V
load current	$\leq 30$ mA
Short-circuit current	$\leq 50$ mA
Static destruction limit	-1 V to +35 V

**Measuring transmitter feed L+**

Rated voltage	+20 to 26 V
load current	$\leq 60$ mA, short-circuit-proof
Short-circuit current	$\leq 200$ mA clocking
Static destruction limit	-1 to +35 V

**CPU data**

Cycle time	100 ms
Minimum integration speed	$\frac{dy}{dt} = \frac{kp \cdot xd}{tn} = \frac{0.1 \cdot 0.1 \%}{10^4 \text{ s}}$

**A/D conversion except UNI module  
6DR2800-8V**

Procedure	Successive approximation per input > 120 conversions and averaging within 20 or 16.67 ms
Modulation range	-5 % to 105 % of the modulation range
Resolution	11 bits $\underline{\Delta}$ 0.06 % of the modulation range
Zero error	$\leq 0.2$ % of the modulation range
Full scale error	$\leq 0.2$ % of the modulation range
Linearity error	$\leq 0.2$ % of the modulation range
Temperature influence	
Zero point	$\leq 0.05$ %/10 K of the modulation range
Full scale	$\leq 0.1$ %/10 K of the modulation range

**Setpoint- and manipulated variable  
adjustment**

Setting	With 2 keys (more -- less)
Speed	progressive
Resolution	1 digit
wi	0.1 % of rated range 0 to 20 mA
y	

**Parameters**

Setting	With two keys (more – less)
Speed	progressive
Resolution	
Linear parameters, %	$\leq 0.1 \%$
Linear parameters, physical	1 digit
Logarithmic parameters	128 values/octave
Accuracy	
Time parameters	$\pm 2 \%$
All others	Resolution accordingly, absolute

**Display technique**

<b>- x- and w-Digital display</b>	4digit 7-segment LED
Color	red
Digit height	7 mm
Display range	Adjustable start and end
Number range	-1999 to 9999
Overrun	<-1999:       -oFL >9999:        oFL
Decimal point	adjustable (fixed point) _.---- to -----
Refresh rate	Adjustable 0.1 to 9.9 s
Resolution	1 digit but not better than AD-converter
Display error	corresponding to AD-converter and analog inputs
<b>- x- and w-Analog display</b>	LED array vertical 30 LEDs
Color	red
x	green
w	0 to 100 %
Display range	flashing first or last LED
Overrun	cyclic
Refresh rate	1.7 % by alternate glowing of 1 or 2 LEDs,
Resolution	the center of the illuminated field serves as a pointer
<b>- y-display (digital)</b>	2digit 7-segment-LED
Color	red
Digit height	7 mm
Display range	0 to 100 %
Overrun	-9 % to 109 %, display >99 % h0 to h9
Refresh rate	Adjustable 0.1 s to 9.9 s
Resolution	1 %

### 2.6.3 Option module

#### 6DR2800-8J/R

Analog inputs AI3 (slot 1), AI4 (slot 2)

Signal converter for	Current	Voltage	Resistance potentiometer
Order number:	6DR2800-8J	6DR2800-8J	6DR2800-8R
Range start	0 or 4 mA <sup>1)</sup>	0 V or 2 V <sup>1)</sup> or 199.6 mV <sup>1)</sup>	0 Ω
Min. span (100 %)			$\Delta R \geq 0.3 R$ <sup>3)</sup>
Max. zero point suppression			$RA \leq 0.2 R$ <sup>3)</sup>
Range full scale	20 mA	10 V, 998 mV	1.1 R <sup>3)</sup>
Dynamic range	-4 to 115 %	-4 to 115 %	-4 to 115 %
Transmitter fault message MUF	-2,5 % $\geq$ MUF $\geq$ 106.25 %		
Input resistance			
Difference	49.9 Ω $\pm$ 0.1 %	200 kΩ	
Common mode	500 kΩ	$\geq$ 200 kΩ	
Permissible common mode voltage	0 to +10 V	0 to +10 V	
Supply current			5 mA $\pm$ 5%
Line resistance			
Three-wire-circuit			per < 10 Ω
Filter time constant $\pm$ 20 %	50 ms	50 ms	50 ms
Error <sup>2)</sup>			
Zero point	$\leq$ 0.3 %	$\leq$ 0.2 %	$\leq$ 0.2 %
Gain	$\leq$ 0.5 %	$\leq$ 0.2 %	$\leq$ 0.2 %
Linearity	$\leq$ 0.05 %	$\leq$ 0.05 %	$\leq$ 0.2 %
Common mode	$\leq$ 0.07 %/V	$\leq$ 0.02 %/V	-
Influence of temperature <sup>2)</sup>			
Zero point	$\leq$ 0.05 %/10 K	$\leq$ 0.02 %/10 K	$\leq$ 0.1 %/10 K
Gain	$\leq$ 0.1 %/10 K	$\leq$ 0.1 %/10 K	$\leq$ 0.3 %/10 K
Static destruction limit			
between the inp.	$\pm$ 40 mA	$\pm$ 35 V	$\pm$ 35 V
referenced to M	$\pm$ 35 V	$\pm$ 35 V	$\pm$ 35 V
	$\pm$ 500 V	$\pm$ 500 V	$\pm$ 500 V

1) Start of measuring by structuring

2) Without errors of A/D-converter

3) with  $R = RA + \Delta R + RE$  adjustable in three ranges:  $R = 200 \Omega$ ,  $R = 500 \Omega$ ,  $R = 1000 \Omega$

Table 2-2 Technical data for module 6DR2800-8J/R



**6DR2800-8V UNI-module** Analog input AI3 (slot 1)

<b>Analog input AI3</b>	<b>mV</b> <sup>1)</sup>	<b>TC</b> <sup>2)</sup>	<b>Pt100</b>	<b>R</b>	<b>R</b>
Slot 1		°C		R ≤ 600 Ω	R ≤ 2.8 kΩ
Start of scale MA	≥ -175 mV	≥ -175 mV	≥ -200 °C	≥ 0 Ω	≥ 0 Ω
Full scale ME	≤ +175 mV	≤ +175 mV	≤ +850 °C	≤ 600 Ω	≤ 2.8 kΩ
Span Δ = ME – MA	parameterizable 0 to Δmax				
Min. recommended span	5 mV	5 mV	10 K	30 Ω	70 Ω
Transmitter fault message MUF	-2.5 % ≥ MUF ≥ 106.25 % <sup>3)</sup>				
Input current	≤ 1 μA	≤ 1 μA	-	-	-
Supply current	-	-	400 μA	400 μA	140 μA
<b>Potential isolation</b>					
Test voltage	500 V AC				
Perm. common mode voltage	≤ 50 V UC	≤ 50 V UC	-	-	-
<b>Line resistance</b>					
2L: RL1+RL4	≤ 1 kΩ	≤ 300 Ω	≤ 50 Ω	-	-
3L: (RL1) = RL2 = RL4	-	-	≤ 50 Ω	-	-
4L: RL1 to RL4	-	-	≤ 100 Ω	-	-
Open loop signaling	without	≥ 500 to 550 Ω	all terminals	Open loop between Terminal 2-3	
<b>Error</b>					
Transmission	± 10 μV	± 10 μV	± 0.2 K	± 60 mΩ	± 200 mΩ
Linearity	± 10 μV	± 10 μV	± 0.2 K	± 60 mΩ	± 200 mΩ
Resolution/noise	± 5 μV	± 2 μV	± 0.1 K	± 30 mΩ	± 70 mΩ
Common mode	± 1 μV/10 V	± 1 μV/10 V	-	-	-
Internal reference point	-	± 0.5 K	-	-	-
<b>Temperature error</b>					
Transmission	± 0.05 %/10 K <sup>3)</sup>				
Internal reference point	-	± 0.1 K/10 K	-	-	-
Static destruction limit	± 35 V	± 35 V	-	-	-
Cycle time	100 ms	200 ms	300 ms	200 ms	200 ms
Filter time constant adaptive <sup>4)</sup>	<1.5 s	<2 s	<2 s	<1.5 s	<1.5 s

1) 20 mA, 10 V with measuring range plug 6DR2805-8J

2) Types, see structure switches, internal reference point (plug-in terminal block) 6DR2805-8A

3) Reference to parameterizable span Δ= ME – MA

4) In series with adaptive filter changeable by time constant t3 (onPA)

Table 2-3 Technical data for UNI-module 6DR2800-8V

**6DR2805-8J Measuring range plug 20 mA/10 V**

- **20 mA**
  - conversion to 100 mV ±0,3 %
  - Load terminal 1-2 50 Ω
  - 1-3 250 Ω
  - Stat. destruction limit ±40 mA
  
- **10 V**
  - divider to 100 mV ±0,2 %
  - Input resistance 90 kΩ
  - Statistical destruction limit ±100 V

**6DR2801-8D 2DO Relay 35 V**      Digital outputs DO3 and DO4 (slot 3)

- **Contact material** Ag / Ni
  
- **Contact load capacity**
  - Switching voltage
    - AC ≤ 35 V
    - DC ≤ 35 V
  - Switching current
    - AC ≤ 5 A
    - DC ≤ 5 A
  - Rating
    - AC ≤ 150 VA
    - DC ≤ 100 W at 24 V
    - ≤ 80 W at 35 V
  
- **Service life**
  - mechanical 2x10<sup>7</sup> switching cycles
  - electrical
    - 24 V/4 A ohmic 2x10<sup>6</sup> switching cycles
    - 24 V/1 A inductive 2x10<sup>5</sup> switching cycles
  
- **Spark quenching element**
  - Series circuit 1 μF/22 Ω parallel to it varistor 75 Vrms

**6DR2801-8E 4DO 24 V, 2DI** Digital outputs DO3 to DO6 and DI3 to DI4 (slot 3)**- Digital outputs**

Signal status 0	≤ 1.5 V or open, residual current ≤ 50 μA
Signal status 1	19 to 26 V
load current	≤ 30 mA
Short-circuit current	≤ 50 mA, clocking
Static destruction limit	-1 V to +35 V

**- Digital inputs**

Signal status 0	≤ 4.5 V or open
Signal status 1	≥ 13 V
Input resistance	≥ 27 kΩ
Static destruction limit	± 35 V

**6DR2801-8C 5DI 24 V** Digital inputs DI3 to DI7 (slot 3)

Signal status 0	≤ 4.5 V or open
Signal status 1	≥ 13 V
Input resistance	≥ 27 kΩ
Statistical destruction limit	± 35 V

**6DR2803-8P PROFIBUS-DP**

Transmittable signals	RS 485, PROFIBUS-DP-protocol
Transmittable data	Operating state, process variables, parameters and structure switches
Transmission procedure PROFIBUS-/DP-protocol	According to DIN 19245, Part 1 and Part 3 (EN 50170)
Data rate	9.6 kbit/s to 1.5 Mbit/s except 45.45 kBit/s
Station number	0 to 125
Time monitoring of the data communication	structurable on the controller in connection with DP-watchdog
Electrical isolation between Rxd/Txd-P/-N and the controller	50 V UC common mode voltage
Test voltage	500 V AC
Repeater-control signal CNTR-P	TTL-level with 1 TTL-load

Supply voltage  $V_P$  (5 V) 5 V -0.4 V/+0.2 V; short-circuit-proof  
line lengths, per segment at 1.5 Mbit/s 200 m, see ET 200-Manual 6ES5 998-3ES12 for further details

### 6DR2803-8C Serial interface

Transmittable signals	RS 232, RS 485 or SIPART BUS *) shuntable
Transmittable data	Operating state, process variables, parameters and structure switches
Transmission procedure	According to DIN 66258 A or B
Character format	10 bits (start bit, ASCII-characters with 7 bits, parity bit and stop bit)
Hamming-distance h	2 or 4
Data rate	300 to 9600 bit/s
Transmission	Asynchronous, semiduplex
Addressable stations	32
Time monitoring of the data communication	1 s to 25 s or without
Electrical isolation between Rxd/Txd and the controller	
max. common mode voltage	50 V UC
Test voltage	500 V AC

	RS 232	RS 485
Receiver input Rxd Signal level 0 Signal level 1 <sup>1)</sup> Input resistance	0 to +12 V <sup>2)</sup> -3 to -12 V <sup>2)</sup> 13 k $\Omega$	$U_A > U_B$ , +0.2 to +12 V $U_A < U_B$ , -0.2 to -12 V 12 $\Omega$
Send output Txd Signal level 0 Signal level 1 <sup>1)</sup>	+5 to +10 V -5 to -10 V	$U_A > U_B$ , +1.5 to +6 V $U_A < U_B$ , -1.5 to -6 V
Load resistance	$\leq 1.67$ mA	54 $\Omega$

1) Signal status 1 is the rest status

2) Input protected with 14 V Z-diode, higher voltages with current limiting to 50 mA possible.

### Line capacitance and lengths

at 9600 bits/s

	Line capacitance	Reference values line lengths	
		Ribbon cable without shield	Round cable with shield
RS 232 point-to-point	$\leq 2.5$ nF	50 m	10 m
RS 485 bus	$\leq 250$ nF	1,000 m	1,000 m

\*) SIPART bus operation is no longer possible!  
The bus driver is no longer available!

**6DR2804-8A/B Coupling relay 230 V**

1 relay module	6DR2804-8B
2 relay modules	6DR2804-8A
per relay module	2 relays with 1 switching contact each with spark quenching element
<b>- Contact material</b>	Silver-cadmium oxide
Switching voltage	
AC	≤ 250 V
DC	≤ 250 V
Switching current	
AC	≤ 8 A
DC	≤ 8 A
Rating	
AC	≤ 1250 VA
DC	≤ 30 W at 250 V ≤ 100 W at 24 V
<b>- Service life</b>	
mechanical	2 × 10 <sup>7</sup> switching cycles
electrical AC 220 V, ohmic	2 × 10 <sup>6</sup> /I(A) switching cycles
<b>- Spark quenching element</b>	Series circuit 22 nF/220 Ω parallel plus varistor 420 V <sub>rms</sub>
<b>- Exciter winding</b>	
Voltage	+19 to +30 V
resistance	1.2 kΩ ± 180 Ω
<b>- Electrical isolation between</b>	
Exciter winding – contacts	Safe isolation <sup>1)</sup> by reinforced isolation, air- and creep lines for overvoltage class III <sup>1)</sup> and degree of contamination 2 <sup>1)</sup>
Relay module – relay module (6DR2805-8A)	
contact – contact of a relay module	Safe isolation <sup>1)</sup> by reinforced insulation, air- and creep lines for overvoltage class II <sup>1)</sup> and degree of contamination 2 <sup>1)</sup>
	<sup>1)</sup> according to DIN EN 61010 Part 1
<b>- Type of protection</b>	
Housing	IP50 according to DIN 40050
Connections (in plugged state)	IP20 according to DIN 40050

- **Housing material** Polyamide 66
- **Mounted on rail**
  - NS 35/7.5 DIN EN 50022
  - NS 35/15 DIN EN 50035
  - NS 32 DIN EN 50035
- **Dimensioned drawing** see fig. 2-7

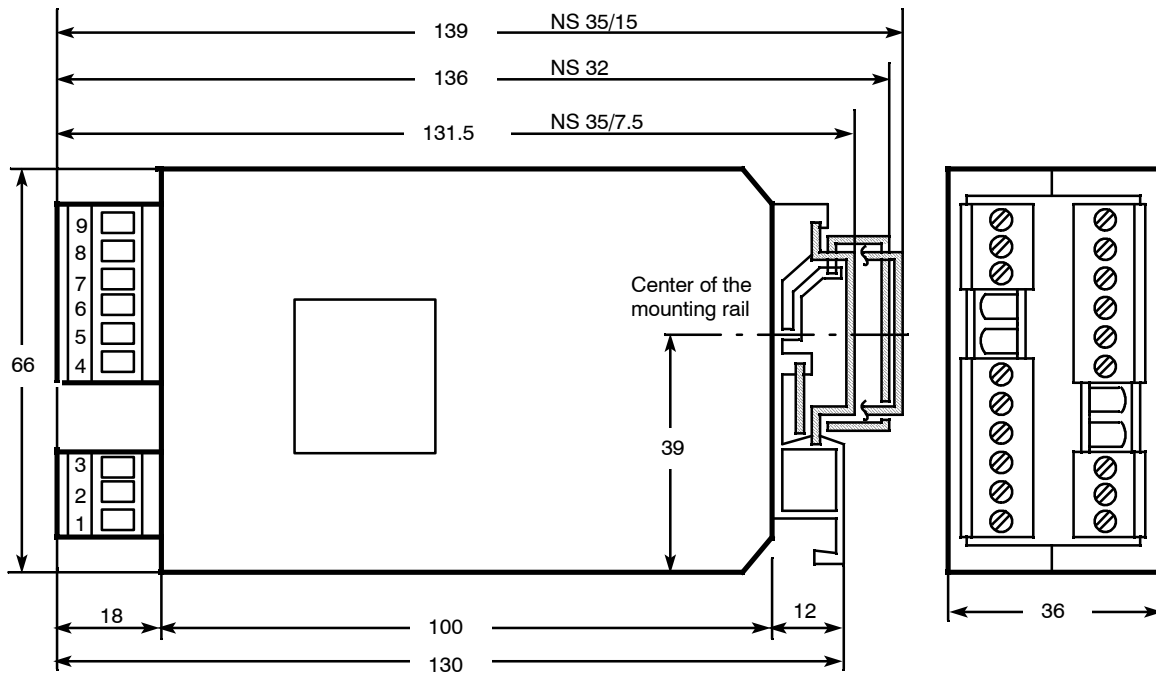

Figure 2-7 Dimensioned drawing coupling relay, dimensions in mm

## 3 Functional description of the structure switches

### 3.1 General

The controller is adapted to the respective job by structure switches. The factory setting corresponds to the most usual setting of the individual functions so that only few structure switches usually need to be set selectively during commissioning. However, it is recommendable to compare the compatibility of the individual structure switch settings with the task in any case.

The structure switches S1 and S2 are fundamentally important. With S1 the controller type is set and thus the processing of command variable, main controlled variable and auxiliary controlled variables up to control difference generation determined. With S2 the controller output structure is set and thus the processing of the automatic-manual-, safety- and tracking variables as well as the manipulated variable output determined as a K- or S-output.

The functions of structure switches S3 to S81 correspond to the logical order of signal processing. S82 and S83 describe the restart conditions, S84 to S91 the transmission procedure of the serial interface.

The structure switches are described in this order in the following description.



#### NOTE

The control elements on the front are shown on page 5 and specified by the digits in the text in brackets. The structure switches are designated by S\*\*.

### 3.2 Analog input signal processing (S3 to S21)

see fig. 3-1, page 49

Each of the maximum 4 analog inputs is fed through an AD-converter which performs the 50 or 60 Hz interference suppression (S3) by averaging over 20 or 16 2/3 ms. Then standardization to 0 to 100% calculated value takes place per channel of the signal range 0 to 20 mA or 4 to 20 mA. The UNI-module is structured with S6 > 3 and S8 determines its input signal. S9 determines the thermocouple type when a thermocouple input is chosen. The temperature unit for PT100- or thermocouple signals is determined with S10.

At the same time S4 to S7 decide whether operation is to take place with or without range monitoring (transmitter fault). A separate AD-converter routine without averaging is responsible for monitoring so that the manual mode which is possible with S50 comes into action bumplessly in the event of a transmitter fault. The monitor signals per channel on dropping below -2.5% or exceeding +106.25 % with a hysteresis of 0.25 % on the digital x/w-display. By an OR link of all single messages the group transmitter fault MUF is formed which can be assigned to the digital outputs and negated optionally (see figure 3-1, page 49 and chapter 3.8, page 111). Only the analog inputs selected with the transmitter fault monitor are monitored, displayed on the front panel (the appropriate position stays dark in the case of analog inputs not selected with transmitter fault) and signaled with the OR link. The error message is acknowledged with the Shift key (12). The fault message signal via the OR link is available until the selected analog inputs are back in the working range.

---

After range monitoring, the 4 analog inputs are each fed through a 1st order filter (parameters  $t_1$  to  $t_4$  can be set in the parameterization mode onPA). The factory setting is 1 s.

Now the root of every channel can be extracted with S11 to S14 and they can be linearized with S21. This allows non-linear process variables to be represented physically correctly as well (see chapter 3.10.4 (page 118 for function principle) setting of the 13 vertex values, see fig. 3-35, page 119).

The controllers-, manipulated- or disturbance variables to be processed for the controller types (S1) can be acquired with S15 to S20 from the 4 analog inputs.

The disturbance variable  $z$  is connected either by the D-element or directly to the controller output (S47).  $y_N$  serves as a tracking input for the manipulated variable in K-controllers (S2=0) or S-controllers with external feedback (S2=3) and  $y_R$  as a manipulated variable feedback in S-controllers with internal feedback (S2=2) or as a position feedback in S-controllers with external feedback (S2=3).

The controllers- or process variables are available for assignment to the analog output (S6) and the limit value signal (S76 to S80) and can be read in via the SES. With this input structure most control tasks can be solved in connection with the different controller types and controller output structures.



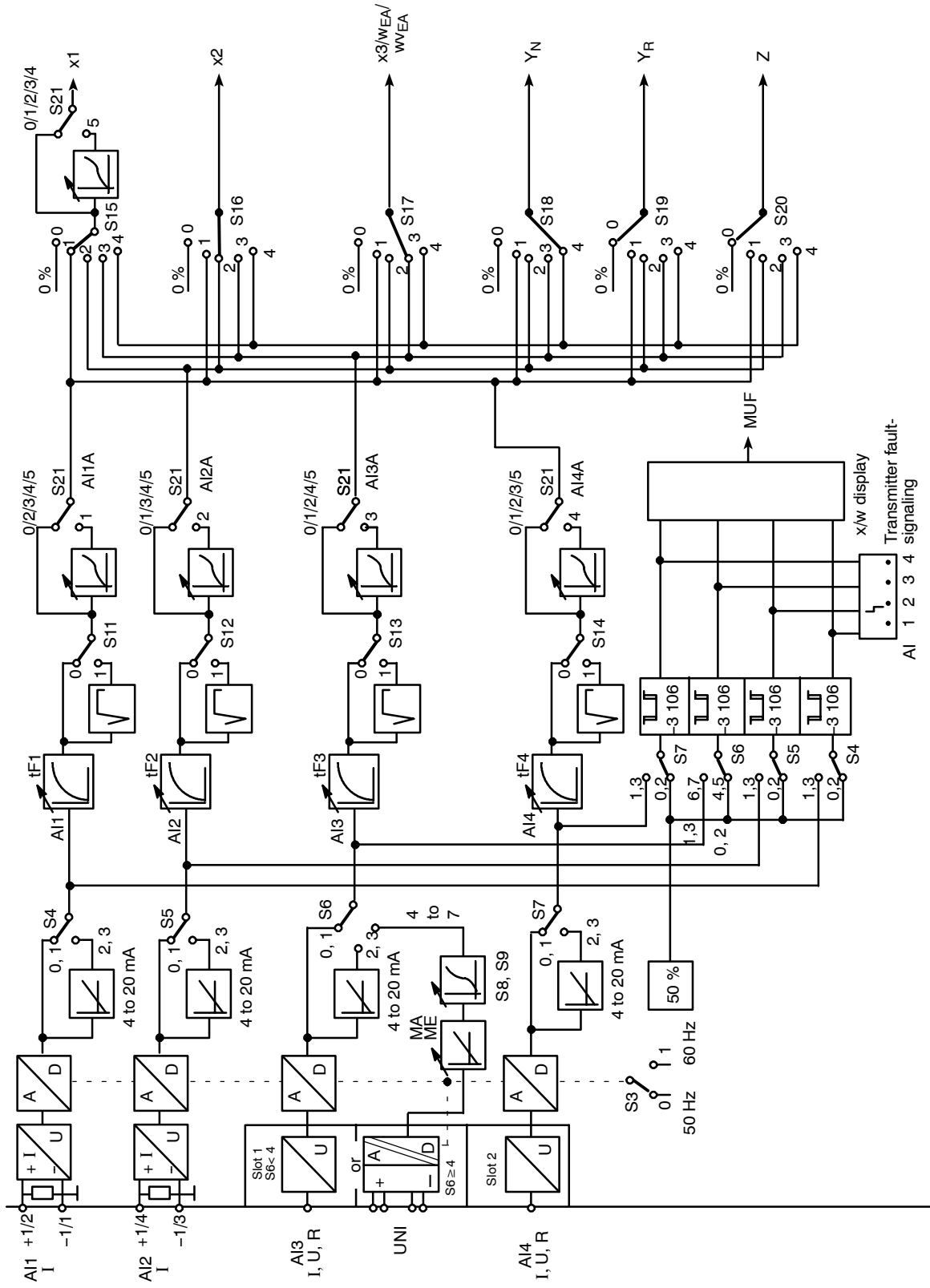

Figure 3-1 Analog input signal processing

### 3.3 Digital input signal processing (S23 to S41)

- **Assignment and direction of effect of the digital inputs (S23 to S40)**

see figure 3-2, page 52

The control signals CB, He ...bLS, bLPS, tSH are assigned by the structure switches S23 to S33, S92 to the digital inputs DI1 to DI7 or the Lo status. The High status is also possible when assigning CB (S23) and P (S27). The control signals can be negated optionally by the structure switches S34 to S40.

The digital inputs DI1 and DI2 of the standard controller can be extended by DI3 to DI7 for example with the option module 5DI (6DR2801-8C) in slot 3 (S22 = 2).

When using the module 4DO 24 V + 2DI (6DR2801-8E) it is possible to extend by two (DI3, DI4) inputs (S22=1).

When using option modules in slot 3, structure switch S22 must be set according to the assignment, otherwise there will be an error message (see chapter 5.5, page 179).

All digital inputs can be read by the SES.

- **Linking the digital inputs DI1 to DI7 with the control signals via the SES. (S41, S42, S51 and S85)**

see figure 3-3, page 53

The control signal CB (S23) may be available at the digital input (S41) either as a static signal or as a pulse (key operation on control desk). Every positive edge trips the flip-flop when selecting the pulse input. In the following descriptions the output status of the flip-flop is assumed as CB.

All control signals (bLb as of software –B3, tSH as of software –B5) can also be specified in S85 = 2, 3, (4, 5)<sup>1)</sup> via the SES and or-linked with the corresponding control signals by the digital inputs. Since the top operation hierarchy in a computer link should be with the autarchic single controller, the control signals can be switched off by the SES by rounding with  $RC = \overline{Int} \wedge CB$  via the Internal/External key (16) of the controller or via  $CB_{ES}$  (optionally time-monitored) or via  $CB_{DI}$  (central Computer Fail line).

In addition the internal flip-flop can be activated at S85 = 2 to 5 parallel to pressing the keys via  $Int_{ES}$ .

The CB-signal is formed at S85 = 2, (4)<sup>1)</sup> as an OR-function of  $CB_{ES}$  via the serial interface and  $CB_{DI}$  via a digital input so that operation can take place optionally with one signal.

<sup>1)</sup> as of software version –A5

At  $S85 = 3$ , (5)<sup>1)</sup> the OR-function is replaced by an AND-function so that the CB set by the SES can be reset via a central Computer Fail line.

At the same time, S85 switches over the sources for the external setpoint  $w_{ES}$  or  $w_{EA}$  and for the tracking manipulated variable  $y_{ES}$  or  $y_N$ . The depth of intervention is determined additionally by the serial interface. This makes it possible to specify the process variables analogly for example and the corresponding status signals via the SES.

The function  $RC = \overline{Int} \wedge CB$  (computer operation) also controls the command variable switching in the controller types  $S1 = 0$  to 4, i.e. also in SPC-operation or the disturbance variable switching in DDC-operation (see chapter 3.4, page 55).

The two controller types  $S1 = 5/6$  operate without command variable switching. The Internal key and the control signal CB are available with the link  $\overline{RC} = Int \vee \overline{CB}$  for locking operation through the serial interface (e. g. when linking to control systems).

At  $S41 = 0$  a static switchover by the logic function  $RC = \overline{Int} \wedge CB$  takes place. In the case of the preset to Int (Internal LED (17) off) you can switch statically with CB between controller values and computer values (command- and manipulated variables). The computer standby CB is displayed negated by the  $\overline{C}$ -LED (18) ( $\overline{C} = CB$ ,  $CB = 1 \triangleq \overline{C}$  LED off). The computer standby of the controller is signaled negated as a message signal  $\overline{RB} = Int$ . Computer operation RC is also signalled negated as a message signal  $RC = \overline{Int} \wedge CB$ .

At  $S41 = 1$  static switching with acknowledgement takes place. Every time the computer is recovered (CB from 0  $\rightarrow$  1) If the internal flip-flop is set to 1 (internal LED on,  $\overline{C}$  LED off), so that computer operation  $RC = \overline{Int} \wedge CB$  only becomes effective after pressing the internal key ( $Int = 0$ ).

With  $S42 = 0/2$  the internal/external key is set out of order and only internal- or external operation is pre-selected.

The control signal H is generated as an OR-function by the Manual-/Automatic key (11) with subsequent flip-flop (Hi) and the control signal He whereby He can be preset by the SES or the digital inputs in the way described above.

With the structure switch S51 Automatic-/Manual switching can be blocked at the controller front ( $S51 = 1$  only Automatic or  $S51 = 2$  only Manual. It is still possible to switch to manual operation by He in the "Only Automatic" position. The Manual LED (12) always indicates the active status (see also chapter 3.6, page 94).

At  $S51 = 0$  to 2, He is connected statically by both the SES and the digital inputs. At  $S51 = 3/4$  the connection is made dynamically, i.e. every positive edge causes manual-automatic-manual operation switching. In addition, with structure switch  $S51 = 4$  the locking of  $He_{ES}$  with  $\overline{RC} = Int \vee \overline{CB}$  is released.

1) as of software version -A5

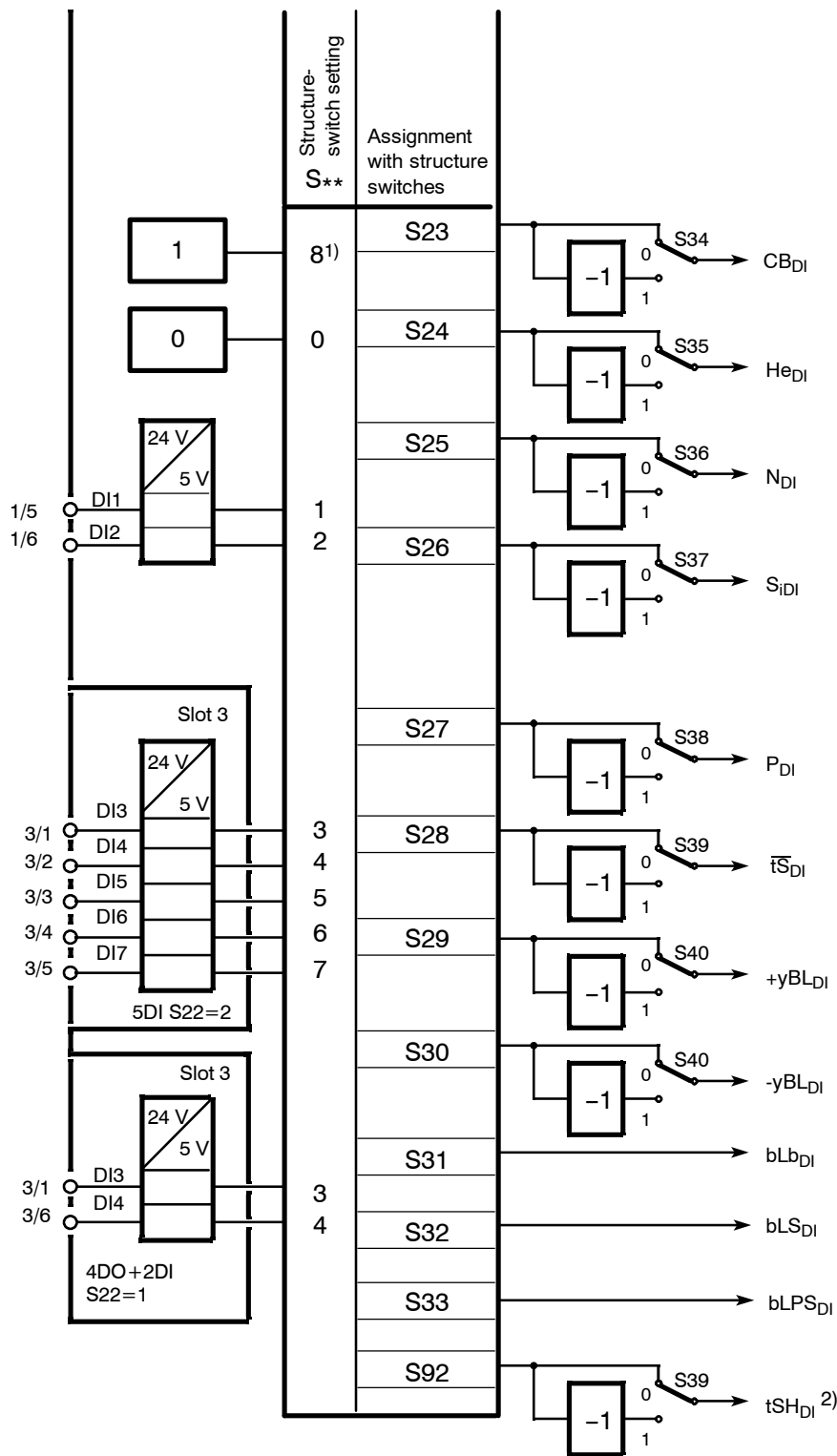
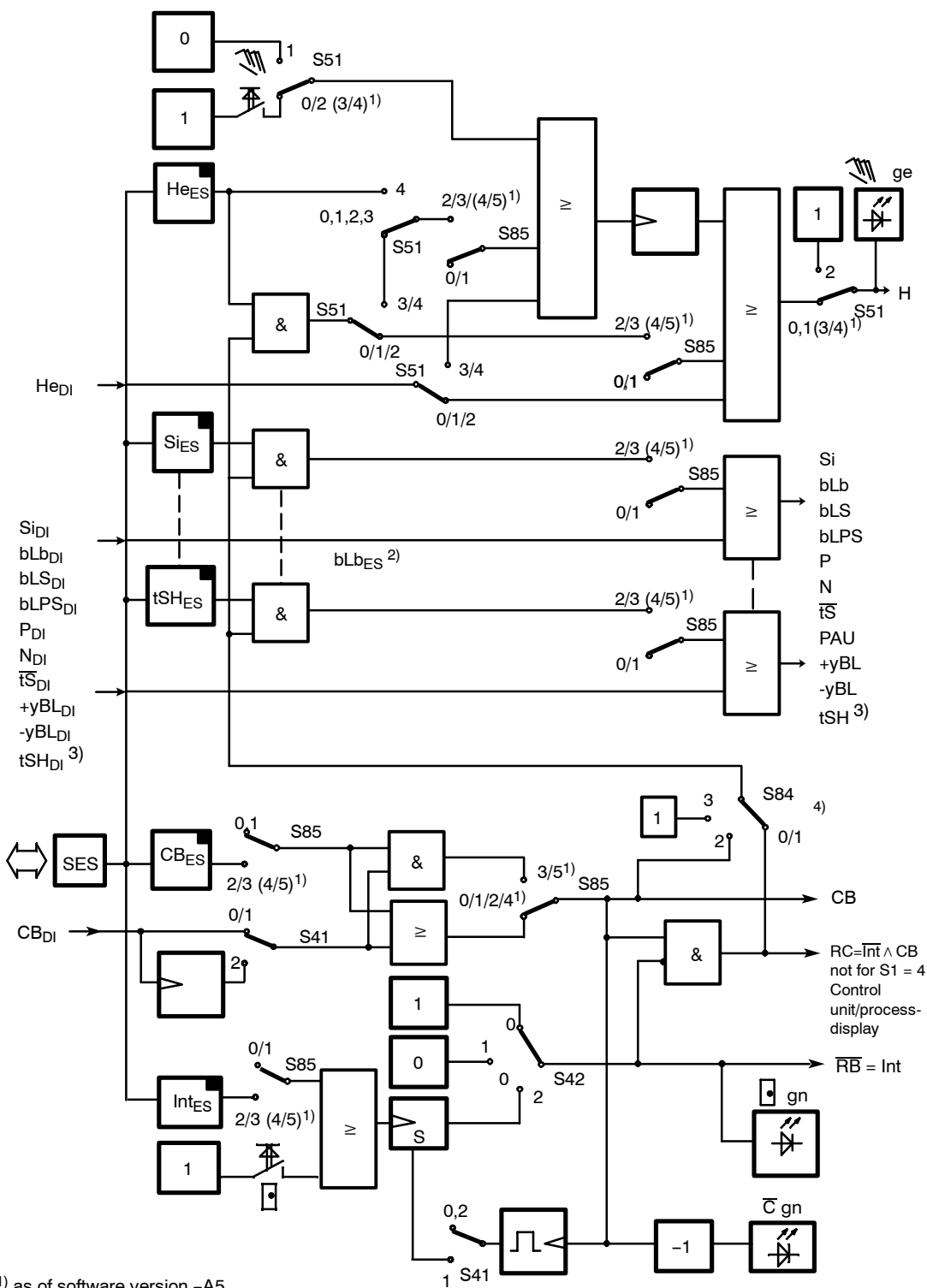

Figure 3-2 Assignment and direction of action of the digital inputs S23 to S40



1) as of software version -A5  
2) as of software version -B3  
3) as of software version -B5  
4) as of software version -C1

Figure 3-3 Linking the digital inputs DI1 to DI7 with the control signals via the SES (S41, S42, S51, S85)

● **Functional explanation of the control signals**

CB	<i>Computer-standby</i> Depending on the controller type this digital signal together with the Internal/External key effects either switching in the setpoint range or DDC-operation begins. Central computer-fail-line in SPC and DDC-operation.
He	<i>Manual external</i> This signal blocks the output of the controller and enables direct manual adjustment of the manipulated variable on the front control panel.
N	<i>Tracking</i> With this signal the output of the K-controller and the three-position-stepper controller with external position feedback is tracked to the tracking signal $y_N$ .
Si	<i>Safety operation</i> In K-controllers and three-position-stepper controllers with external position feedback, the manipulated variable adopts the parameterized safety value. In three-position-stepper controllers with internal feedback the manipulated variable runs independently of the safety setting value to a defined limit position.
bLS	<i>Blocking structuring</i> The whole configuration is blocked with the exception of the online parameterization level.
bLPS	<i>Blocking parameterization and structuring</i> The entire configuring of the instrument is blocked, this means the parameterization as well. Only the normal process operation according to the preselected controller type is permitted.
bLb	<i>Blocking operation</i> This signal blocks the entire front panel operation of the instrument.
P	<i>P-Operation controller</i> With this signal the controller is switched to P-operation.
$\bar{tS}$	<i>setpoint ramp</i> The set setpoint ramp time can be made ineffective with this signal ( $\bar{tS}$ = High $\triangleq$ ramp switched off).
tSH	<i>setpoint hold (setpoint ramp)</i> The setpoint change is stopped with this signal. The setpoint change continues when the signal is reset.
$\pm yBL$	<i>Direction-dependent blocking of the manipulated variable</i> Direction-dependent limiting of the manipulated variable by external signals, e.g. from the limit switches of the actuating drives. This limiting is effective in every operating mode.

## 3.4 Controller types (S1, S42 to S45)

### 3.4.1 General, recurrent functions

- **Manual setpoint preset  $w_i$  or nominal ratio preset  $w_{vi}$  on the control front panel.**

The internal setpoint can always be adjusted with the  $\pm \Delta w$ -keys (14, 15) when the green internal-LED (1) lights up. The adjusting facility is marked by ↗ in the tables. Exceptions to this rule are expressly mentioned in the individual controller types. The adjustment operates incrementally, in the first step with a resolution of 1 digit and then an adjustment progression so that major changes can also be performed quickly. After every interruption in the adjustment by releasing the keys, the progression starts again with the smallest adjustment step.

- **Setpoint preset  $w_i$  or nominal ratio preset  $w_{vi}$  by the SES**

Every time the internal setpoint can be adjusted by the keys (7, 8) on the control front panel, it is also possible to make a preset with the SES. Since only absolute and not incremental adjustment is possible with the SES, it is advisable to use the setpoint ramp  $tS$  to avoid steps.

In addition, the control signal  $Int$ , the automatic-manual switching and the manual manipulated variable adjustment can be set via the SES. This makes a complete, parallel process operation via the SES possible (see also chapter 3.6, page 94 ).

- **Source for the external setpoint (S85)**

The external setpoint  $w_E$  may come from two different sources depending on the controller type.

External setpoint as an absolute value via the analog inputs ( $w_{EA}$ )	S85 = 0, 1, (4, 5) <sup>1)</sup> or
external setpoint as an absolute value via the SES ( $w_{ES}$ )	S85 = 2, 3

- **Setpoint ramp  $tS$**

With the parameter  $tS$  (oFPA), the adjustment speed of the active setpoint  $w$  (in the ratio controller S1 = 3 the active nominal ratio) can be set over 0 to 100 %. At  $tS = oFF$  the adjustment speed moves towards  $\infty$ . With the control signal  $\bar{tS} = 1$  the set setpoint ramp is switched off (the setpoint then changes suddenly).

With the setpoint ramp, sudden setpoint switchings to the untracked variables  $SH$ ,  $w_i$ ,  $w_{ES}$  at S45 = 1 and  $w_{EA}$ , can be avoided.

<sup>1)</sup> as of software version –A5

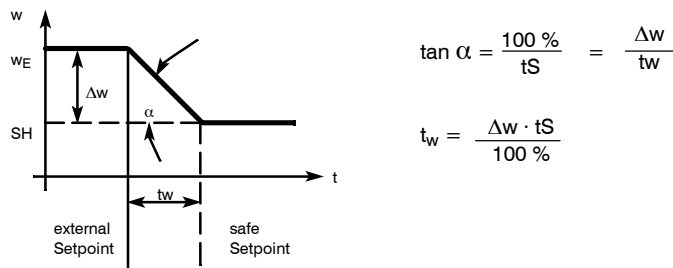

Figure 3-4 Setpoint switching with ramp

The setpoint change/setpoint ramp can be stopped with the control signal tSH. The setpoint change continues when the signal is reset.

- **Setpoint limits SA, SE**

With the parameters SA and SE (oFPA) the effective setpoint  $w$  can be limited to minimum value (SA) and maximum value (SE) in the range from -10 to 110 %.

Exception: Ratio controller (S1 = 3)

- **Tracking of the ineffective setpoint to the active setpoint (S45)**

Normally the ineffective setpoint is tracked to the effective setpoint so that the setpoint switching is bumpless. The internal setpoint ( $w_i$ ) and the external setpoint can be tracked via the SES ( $w_{ES}$ ). The safety setpoint SH cannot be tracked.

The external setpoint  $w_{EA}$  through the analog inputs is only indirectly trackable by tracking the feeding instrument to the internal setpoint.

At S45 = 1 the tracking is suppressed. This switch setting is always required especially in follow-up controllers if the internal setpoint represents a kind of safety function or if multiple setpoint operation is to be run in the fixed setpoint controller (S1 = 0).

- **x-tracking (S43)**

With the structure switch S43 = 1, x-tracking (ratio controller xv-tracking) can be switched on. This means that the setpoint is tracked to the actual value or the nominal ratio is tracked to the actual ratio and therefore a control difference  $x_d$  is reset to 0. The tracking always takes place when there is no automatic operation ( $\bar{A}$ ). This is the case in manual mode (H), tracking mode (N), DDC-mode and in operation with safety manipulated variable (Si):  
 $\bar{A} = H \vee N \vee Si$

x-tracking in direction-dependent blocking operation is not possible because the P-step produced by resetting the driving control error to blocking direction would immediately cancel the blocking.

x-tracking takes place without the set setpoint ramp tS. By tracking the setpoint to the actual value (nominal ratio to actual ratio), the control difference  $x_d = 0$  and automatic operation starts absolutely bumplessly. Since it can normally be assumed that, especially in manual operation and in DDC-operation, the actual value has been driven to the desired value during manual- or DDC-operation, the tracked setpoint then corresponds to the rated value.



x-tracking only takes full effect if the tracking of the inactive setpoint is locked onto the active setpoint ( $S45 = 0$ ) so that not only the active setpoint  $w$  but also the setpoint source which is supplying after switching to automatic operation is tracked.

At  $S45 = 1$  (without tracking) the control difference during the  $\bar{A}$ -operation is 0 but the old, untracked setpoint becomes effective again after switching to automatic operation. With the setpoint ramp  $tS$  this step-shaped setpoint change takes place via a time ramp.

This combination is always useful when it is not guaranteed during  $\bar{A}$ -operation (especially in safety mode) that the actual value will be driven to the desired rated value by the actuating manipulation and the tracking variable would not be correct in full x-tracking.

- **Constants c1 to c7**

Linking of the process variables with the constants is possible depending on the controller type, whereby the constants  $c1$  to  $c3$  are used for the control variable links, the constants  $c4$  and  $c5$  for the command variable links.

The constants are set in the parameterization mode onPA.

The constant  $c6$  serves for proportioning the disturbance variable connection  $z$  to the controller output  $y_a$  (see figure 3-7, page 62). It can be set in the parameterization mode onPA.

The constant  $c7$  is used in P-controller operation as a factor for increasing the  $K_p$ -value. (P/PI-switchover, see figure 3-21, page 92).

- **Control signals for the setpoint switching**

If available in the single controller types, the setpoint switching takes place depending on the control signals  $Int$  (Internal/External key) and  $CB$  (Computer standby) as an AND-function  $RC = \bar{Int} \wedge CB$  and its negation. The status of the control signal  $CB$  and the Internal key (16) is indicated by the  $\bar{C}$  LED (18) and the Internal LED (17).

With  $S42$  the Internal/External key (16) can be set out of function and can block in the positions Internal or External (see figure 3-3, page 53). The factory setting is  $S42 = 0$  (only Internal).

With  $S23$ , the  $CB$ -signal can be set to Low or High or assigned to a digital input, (see figure 3-2, page 52). The factory setting is  $S23 = 8$ ,  $CB = High$ .

The setpoint switching can be varied freely with these structuring possibilities.

● **Actual value- and setpoint display**

A red and a green analog display with 1.7 % resolution are arranged on the front module. The green display is assigned to the setpoint, the red display to the actual value. A red, 4-digit digital display is used for displaying both the setpoint- and the actual value. Since only one display is available, the displayed variable is switched using the key (6). The scope of the display is controlled by the structure switch S81. The type of displayed variable is identified by the signal lamps (4) and (5).

The two analog displays always indicate the active setpoint and the current actual value. The difference between the two displays is the control difference  $x_d$  or the control error  $x_w = -x_d$ . The digital actual value-setpoint display also displays the current actual value/setpoint except in the ratio controllers (ratio controller actual ratio/setpoint ratio). The digital display shows the setpoint before the setpoint ramp (ratio controller: nominal ratio after the setpoint ramp).

The following symbols are used in the block diagrams below to simplify the representation:

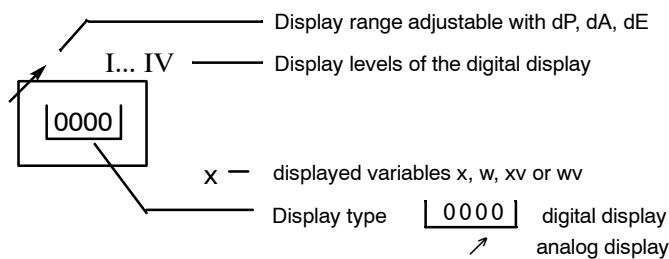

● **Display range**

The *digital display* for  $x$  or  $w$  is a four-digit 7-segment display. The display range for the  $x$ -and  $w$ -display is set together with the parameter dP (decimal point), dA (start value) and dE (end value) in the structuring mode oFPA.

With dA the numeric value is set which is to be displayed at arithmetic value 0 (corresponding to 0 % display in the analog displays). With dE the numeric value is set which is to be displayed at arithmetic value 1 (corresponding to 100 % display in the analog displays). With dP the decimal point is set as a fixed point. If the start value is set less than the end value, an increasing display is given with increasing arithmetic values and vice versa. The number range for the start- and end value respectively is from -1999 to 9999, outside these ranges, -oFL and oFL is displayed in the case of overmodulation in the process operation level. The factory setting is 0.0 to 100.0 %.

With the refresh rate parameter dr (onPA) the digital displays can be settled down in the case of restless process variables. Non-linear process variables can be represented physically correctly by the linearization.

The display range set with dP, dA and dE is transferred depending on the controller type (S1) to the parameters and setpoints which can be assigned to the displayed variable:

With the appropriate assignment, this also applies for the limit value alarms A1 to A4, see chapter 3.10.3, page 117.

The *analog displays* have a fixed display range of 0 to 100 %. The overshoot or undershoot is displayed by the flashing 100 % or 0 %-LED. This is displayed by one or two, alternately lit LEDs. The centre point of the light field represents the "pointer". This display technique doubles the resolution. If a falling characteristic ( $dE < dA$ ) is set for the digital displays, the analog displays are switched in direction of effect except for in the ratio controllers.

### y-display

A 2-digit red digital display is available for the y-display additionally. The corresponding adjustment keys and status-LEDs are allocated to each other in color and space (see also chapter 3.6, page 94 ).

#### 3.4.2 Fixed setpoint controller with 2 independent setpoints (S1 = 0)

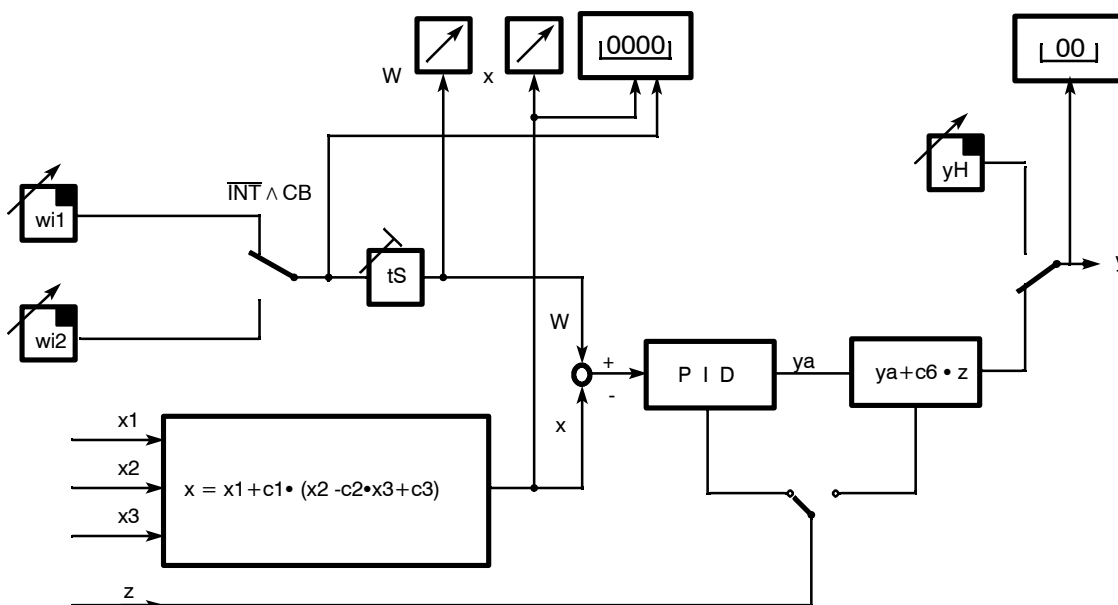

Figure 3-5 Control principle S1 = 0

This controller type can be used as a fixed setpoint controller with 2 independent setpoints (two batch mode) or as a fixed setpoint controller with 1 setpoint, by blocking the Internal/External-switching (factory setting). By linking the inputs  $x_1, x_2, x_3$  with the constants  $c_1, c_2, c_3$  it can be used as a one-, two- or three-component controller.

Switching between the two setpoints which can be set separately on the front panel takes place dependent on the control signals  $\overline{INT}$  and  $CB$  according to table 3-1, page 60. Signaling of the active setpoint takes place on the LEDs Internal and  $\overline{C}$ . As soon as a LED lights,  $w_2$  is active.

Control commands Digital inputs			Alarm signals				Active w at S43=		Explanations
H	N	Si	Front	Front LED	Digital outputs		0	1	
	CB	internal	internal	$\overline{C}$	$\overline{RB}$	$\overline{RC}$			
0	1	0	0	0	0	0	wi1	wi1 (n) <sup>1)</sup>	switchover with CB, Int=0 ← switchover with Int, CB=1 ←
0	0	0	0	1	0	1	wi2	wi2 (n)	
0	1	1	1	0	1	1	wi2	wi2 (n)	
0	0	1	1	1	1	1	wi2	wi2 (n)	
1	1	0	0	0	0	0	wi1	x	switchover with CB, Int=0 ← switchover with Int, CB=1 ←
1	0	0	0	1	0	1	wi2	x	
1	1	1	1	0	1	1	wi2	x	
1	0	1	1	1	1	1	wi2	x	

1) tracking takes place at S45 = 0 and S43 = 1 to the control variable x, the tracking does not apply for switchover wi1/wi2 at S45 = 1 automatic mode starts with wi=x (xd=0), the active setpoint runs to the old set value via the possibly set setpoint ramp tS

2) Factory setting fixed setpoint controller with 1 setpoint (S42 = 0: only Internal, Int = 1, S23 = 8: CB = 1)  $\overline{RB} = \text{Int}$   
 $\overline{RC} = \text{Int} \vee \overline{CB}$

■ Factory setting

Table 3-1 Switching between wi1 and wi2

With the Shift key (6) the digital x/w-display can be switched between the display levels I to IV depending on the position of S81.

In display level II the active w can be displayed, in display level III the main control variable x1. The inactive setpoint is displayed in the display level IV. The displayed active or inactive setpoint can also be adjusted (see table 3-2).

The active setpoint- and actual value is displayed on the analog displays.

Structure switches	Position	Function			
S81	[0] 1 2 3 4 5 6 7	<b>Switching the w/x-digital display</b>			
		Display order			
		I	II	III	IV
		x/xv	w/wv	-	-
		x/xv	w/wv	x1/xv	-
		x/xv	w/wi1/wv	-	wE/wvE/wi2
		x/xv	w/wi1/wv	x1/xv	wE/wvE/wi2
		x/xv	-	-	-
		-	w/wv	-	-
		-	-	x1/xv	-
xv	wv	x1	w		
Identification of the displayed variables by the w- or x-signal lamp: 1 = steady light, 0.5 = flashing light, 0 = off					
Display order					
I	II	III	IV	x-signal lamp w-signal lamp	
1	0	0.5 (0 at S81=6)	0		
0	1	0	0,5		

Table 3-2 Display levels (S81)

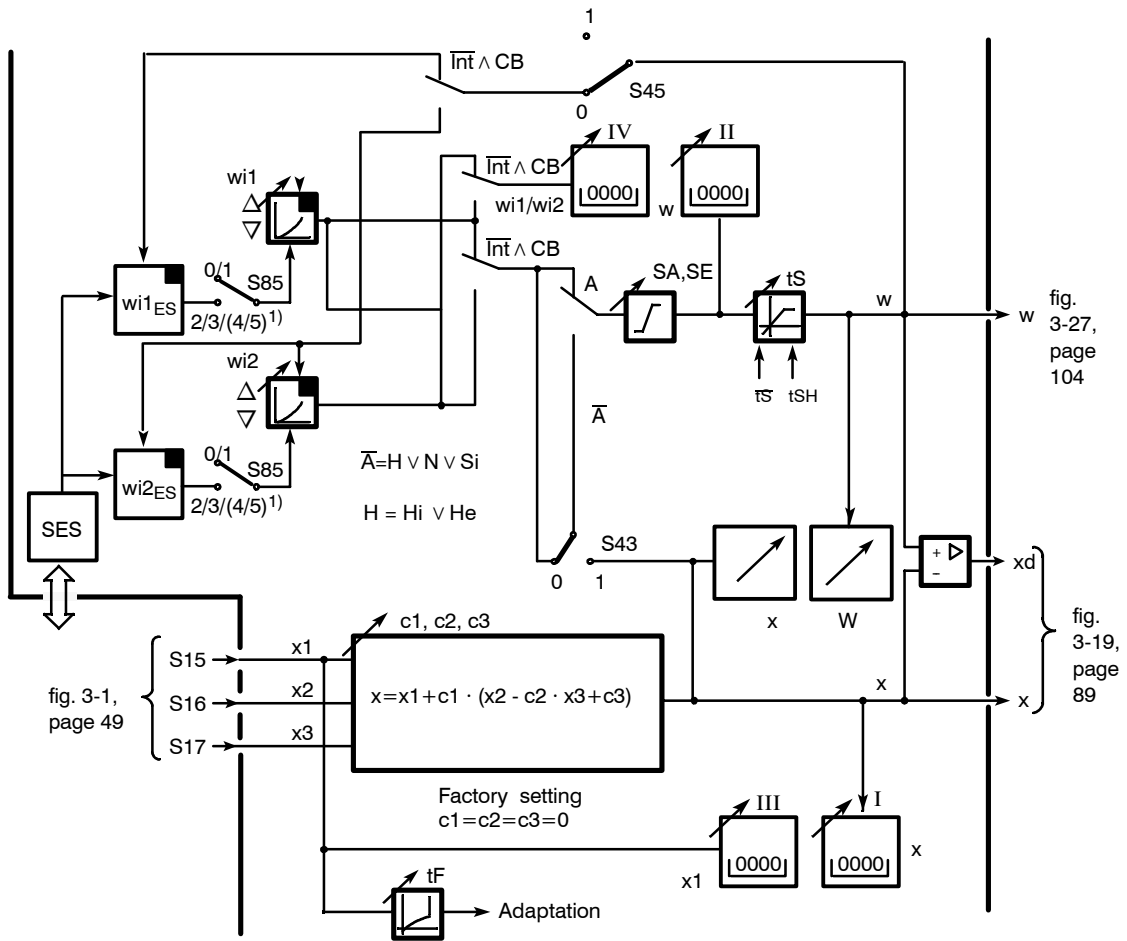

Note: S51=4 is recommended for this controller

1) as of software version -A5

Figure 3-6 Block diagram S1 = 0, fixed setpoint controller with 2 independent setpoints

### 3.4.3 Slave controller, synchronized controller, SPC-controller with Int/Ext-switching (S1 = 1)

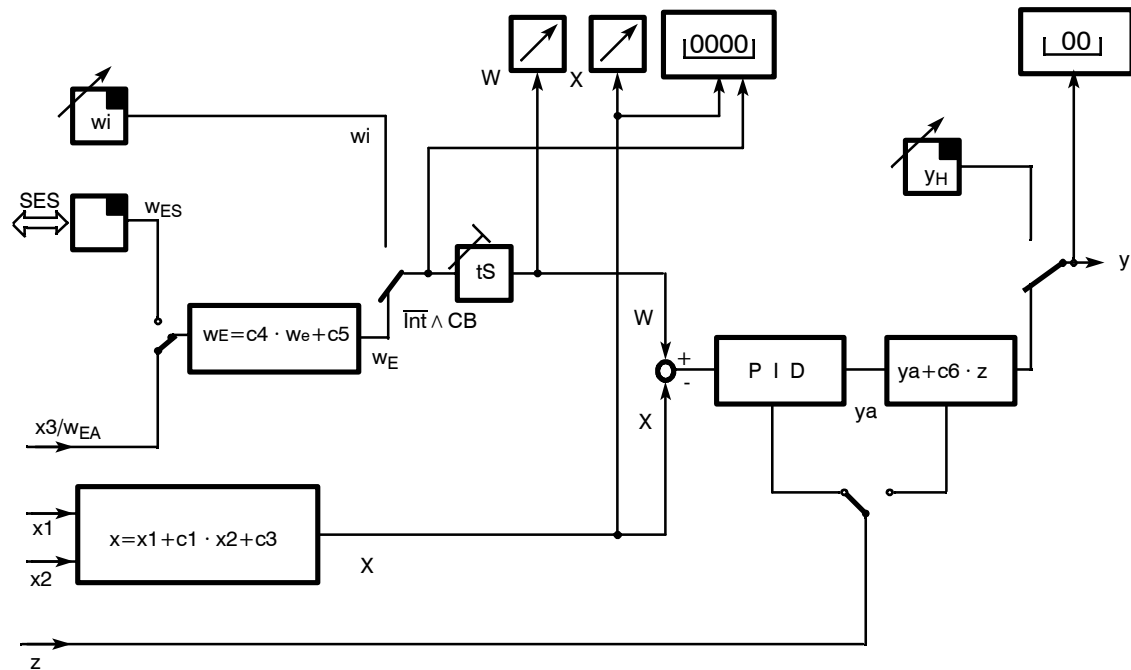

Figure 3-7 Control principle S1 = 1

In this controller type you can switch between the internal setpoint  $w_i$  and the external setpoint  $w_E$  depending on the control signals CB and the Internal-/External key (16) (see table 3-4, page 65 and table 3-5, page 66).

The external setpoint can be set via the analog input  $w_{EA}$  or via the SES ( $w_{ES}$ ) (selection by S85).

This controller type is used for cascade controls with 2 separate controllers (master- and slave controllers), for synchronized controls, fixed setpoint controls with external setpoint preset under console conditions with external setpoint generator and SPC-controls (setpoint control).

- **SPC-controls**

Here a process computer takes over command of the setpoint during computer operation  $RC = \overline{Int} \wedge CB = 1$ . In the case of computer failure (CB from 1  $\rightarrow$  0) the controller takes over either the last computer setpoint (tracked wi) or the safety setpoint SH (selection via S44).

- **Cascade controls**

A command controller, e.g. a fixed setpoint controller (with the main controlled variable) feeds the external setpoint of a slave controller with its manipulated variable (with the auxiliary controlled variable) and this the final control element. This gives faster control of the main controlled variable in the event of changes in the auxiliary controlled variable, e.g. furnace temperature control (furnace temperature, main controlled variable) with different flow of the medium to be heated (auxiliary controlled variable).

- **Slave controls**

A command controller feeds several synchronized controllers simultaneously whose individual setpoints can be set in a ratio to each other by the constants c4 and c5 and then drag the controlled variables accordingly (controlled variable synchronization).

- **Control signals for the setpoint switching**

The setpoint switching takes place via the logic link  $RC = \overline{Int} \wedge CB$  and its negation (see table 3-4, page 65 and table 3-5, page 66). Both control signals can be set statically to 1 or 0 (int via S49, CB via S24) in addition to their normal functions as Shift key or control signal with the states 1 and 0, see fig. 3-2, page 52 and fig. 3-3, page 53.

The factory setting is  $Int = 1$  (S42 = 0) and  $CB=1$  (S23 = 8), **so that the internal setpoint wi is always active and cannot be switched in the factory setting**

With this setting option it is possible to make the setting only dependent on Int (S42=2, S23= 8) or only dependent on CB (S42=1, S23=1 to 7) as a slave controller with Internal/External-switching. If the switching option is blocked in External position (S42=1, S23=8), the controller operates as a slave controller without Internal/External-switching.

● **Display of the external setpoint  $w_E$**

With the Shift key (6) the digital x/w-display can be switched between the display levels I to IV depending on the position of S81.

In display level II the active w can be displayed, in display level III the main control variable x1. The external setpoint  $w_E$  is displayed in display level IV. The displayed active or inactive setpoint can also be adjusted (see table 3-3).

The active setpoint- and actual value are displayed on the analog displays.

Structure switches	Position	Function				
S81	[0] 1 2 3 4 5 6 7	<b>Switching the w/x-digital display</b>				
		Display order				
		I	II	III	IV	
		x/xv	w/wv	-	-	
		x/xv	w/wv	x1/xv	-	
		x/xv	w/wi1/wv	-	$w_E/wvE/wi2$	
		x/xv	w/wi1/wv	x1/xv	$w_E/wvE/wi2$	
		x/xv	-	-	-	
		-	w/wv	-	-	
		-	-	x1/xv	-	
xv	wv	x1	w			
Identification of the displayed variables by the w- or x-signal lamp: 1 = steady light, 0.5 = flashing light, 0 = off						
Display order						
I	II	III	IV	x-signal lamp w-signal lamp		
1	0	0.5 (0 at S81=6)	0			
0	1	0	0,5			

Table 3-3 Display levels (S81)

● **Operation with 2 or 3 setpoints**

If tracking of the inactive setpoint to the active setpoint is blocked with S45 = 1, a multiple setpoint operation (switching between  $w_i$ ,  $w_E$  and SH is achieved (see table 3-4, page 65) and table 3-5, page 66.

● **Controlled variable processing**

A 2-component control is implemented (disturbance variable connection). With factors c1 and c3 the main controlled variable x1 can connect the auxiliary controlled variable x2 with weighting.



Control signals			Message signals				active w at				Explanations	Com- puter- failure	
Digital inputs		Front	Front		Digital outputs								
H √ N √ Si	CB <sup>1)</sup>	In- ter- nal	In- ter- nal LED	$\bar{C}$ LED	$\bar{RB}$ <sup>4)</sup>	$\bar{RC}$ <sup>4)</sup>	S43=0 S44=0	S43=1 S44=0	S43=0 S44=1	S43=1 S44=1			
0	1	0	0	0	0	0	$w_E(n)^{2)}$		$w_E(n)^{2)}$ $SH^3)$ or $w_i(n, \nearrow)$		Automatic mode, SPC-mode Automatic mode, computer switched off, computer in SPC-standby Automatic mode, computer on standby, controller not in SPC-standby <sup>5)</sup> Automatic mode, computer switched off, computer in SPC- standby		
0	0	0	0	1	0	1	$w_i(n, \nearrow)$						
0	1	1	1	0	1	1	$w_i(n, \nearrow)$			$w_i(n, \nearrow)$			
0	0	1	1	1	1	1	$w_i(n, \nearrow)$			$w_i(n, \nearrow)$			
1	1	0	0	0	0	0	$w_E(n)^{2)}$	x	$w_E(n)^{2)}$ $SH^3)$ or $w_i(n, \nearrow)$	x	Manual-, tracking- or safety mode <sup>5)</sup>		
1	0	0	0	1	0	1	$w_i(n, \nearrow)$	x					x
1	1	1	1	0	1	1	$w_i(n, \nearrow)$	x		$w_i(n, \nearrow)$			x
1	0	1	1	1	1	1	$w_i(n, \nearrow)$	x		$w_i(n, \nearrow)$			x

- 1) The table is shown for static CB-switching without acknowledgement (S41 = 0).
- 2) Source for  $w_E$  at S85 = 0, 1, (4, 5 as of software version -A5) is  $w_{EA}$  or at S85 = 2, 3  $w_{ES}$  (SES). The external setpoint fed in through the SES ( $w_{ES}$ ) is tracked. Tracking is not possible when the external setpoint is fed in via  $w_{EA}$ .
- 3) SH can only be reached after  $w_E$ , if Int = 0 and CB goes from 1 → 0 (computer failure). If CB = 0 and Int is switched from 1 → 0,  $w_i$  is still active. Since SH is not tracked, switching over to SH can take place with the setpoint ramp tS.
- 4) By OR-linking with the digital outputs H, N and the control signal Si no computer standby or computer operation can be signaled in manual-, tracking- or safety operation.
- 5) Factory setting
- (n) tracked to the value active before switching, therefore bumpless switching
- $\nearrow$  adjustable
- Factory setting

Table 3-4 Slave-/synchronized-/SPC-controller with Internal-/External switching S1 = 1 with tracking of the inactive setpoint to the active S45 = 0

Control signals		Message signals					active w at				Explanations
Digital inputs		Front	Front		Digital outputs						
H √ N √ Si	CB <sup>1)</sup>	Internal	Internal LED	$\bar{C}$ LED	$\bar{R}\bar{B}$ <sup>4)</sup>	$\bar{R}\bar{C}$ <sup>4)</sup>	S43=0 S44=0	S43=1 S44=0	S43=0 S44=1	S43=1 S44=1	
0	1	0	0	0	0	0	$w_E^{2)}$		$w_E^{2)}$		Automatic mode <sup>5)</sup>
0	0	0	0	1	0	1	$w_i(\nearrow)$		SH <sup>3)</sup> or $w_i(\nearrow)$		
0	1	1	1	0	1	1	$w_i(\nearrow)$		$w_i(\nearrow)$		
0	0	1	1	1	1	1	$w_i(\nearrow)$		$w_i(\nearrow)$		
1	1	0	0	0	0	0	$w_E^{2)}$	x	$w_E^{2)}$	x	Manual-, tracking- or safety mode <sup>5)</sup>
1	0	0	0	1	0	1	$w_i(\nearrow)$	x	SH <sup>3)</sup> or $w_i(\nearrow)$	x	
1	1	1	1	0	1	1	$w_i(\nearrow)$	x	$w_i(\nearrow)$	x	
1	0	1	1	1	1	1	$w_i(\nearrow)$	x	$w_i(\nearrow)$	x	

- 1) The table is shown for static computer switching without acknowledgement (S41 = 0).  
 2) Source for  $w_E$  at S85 = 1, 2, (4, 5 as of software version -A5) is  $w_{EA}$  or at S85 = 3, 4  $w_{ES}$ . Switching between the setpoints can take place with the setpoint ramp tS.  
 3) SH can only be reached after  $w_E$ , if Int = 0 and CB goes from 1 → 0 (computer failure). If CB = 0 and Int is switched from 1 → 0,  $w_i$  is still active. Since SH is not tracked, switching over to SH can take place with the setpoint ramp tS.  
 4) By OR-linking with the digital outputs H, N and the control signal Si no computer standby or computer operation can be signaled in manual-, tracking- or safety operation.  
 5) Factory setting  
 $\nearrow$  adjustable  
 ■ Factory setting

Table 3-5 Slave-/synchronized-/SPC controller with Internal-/External switching (SPC-controller), S1 = 1 without tracking of the active setpoint to the active setpoint S45 = 1, 2 or 3 setpoint operation

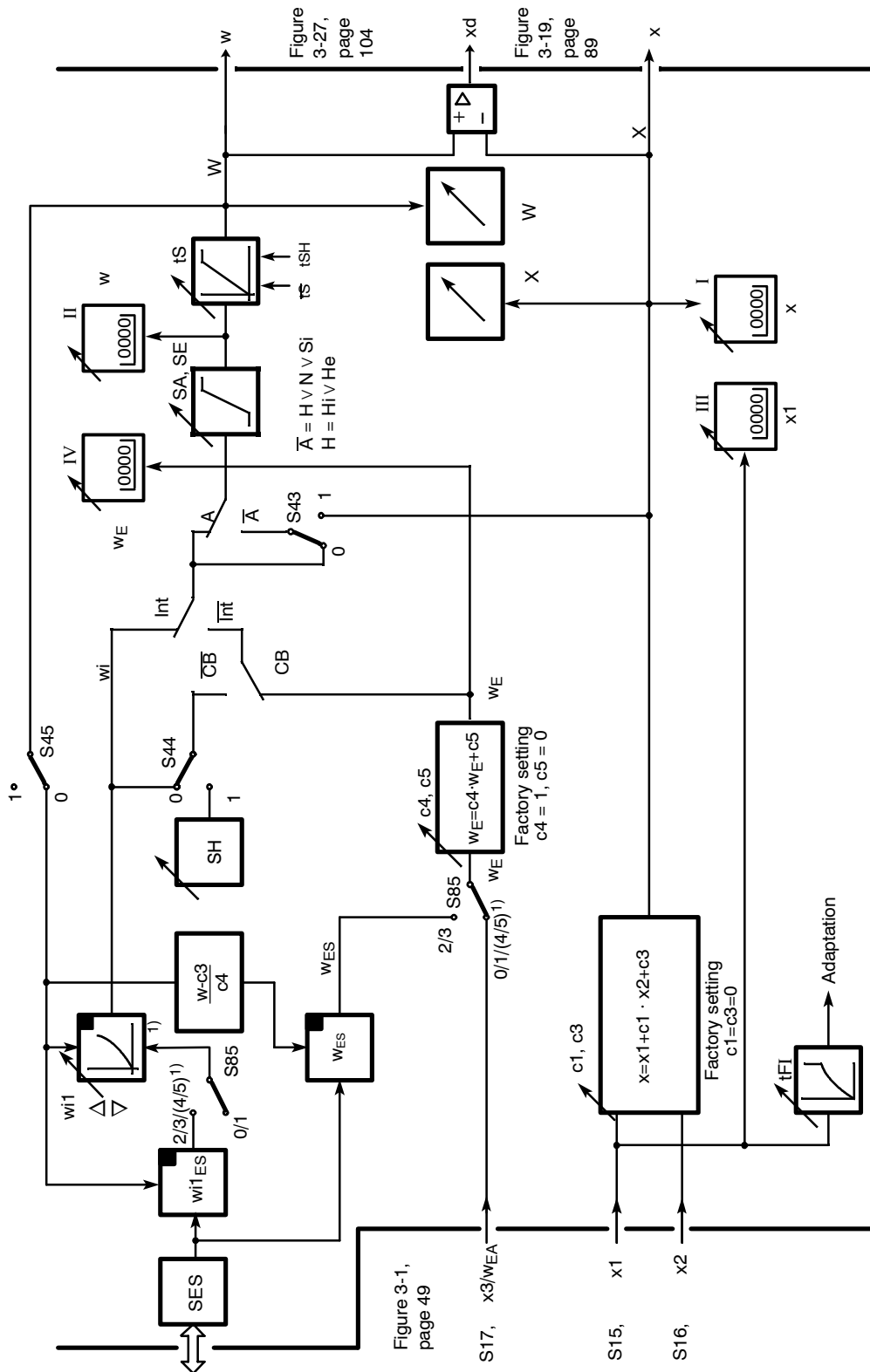

Figure 3-8 Block diagram S1 = 1 slave controller, synchronized controller, SPC-controller

### 3.4.4 DDC-Fixed setpoint controller (S1 = 2)

The DDC-controller has the job of taking over the control circuit as bumpless as possible in the case of a computer failure. During DDC operation- the process computer takes over the control function, the computer is in stand-by-mode and is tracked to the computer manipulated variable. If necessary the control difference is set to zero by x-tracking for absolutely bumpless switching.

In K-controller circuits, the actuating current can be output parallel by the computer periphery to achieve full redundancy. In this case the actuating current of the K-controller is switched off during computer operation (S52 = 1). If the actuating current of the computer is also to be switched off during controller operation, the two currents simply need to be added by OR-diodes. This OR-diode is integrated in the current outputs of the SIPART-controllers.

If the U/I-converter of the K-controller is to be used during computer operation to feed the final control element, the actuating current cutoff must be cancelled (S52 = 0).

The DDC-mode corresponds to tracking mode of the other controller types with the difference that the switching to tracking mode takes place not via the control signal N but as a function of the control signal CB and the Internal/External key:

$$\text{DDC-mode} \triangleq \text{RC} = \overline{\text{int}} \wedge \text{CB} = 1$$

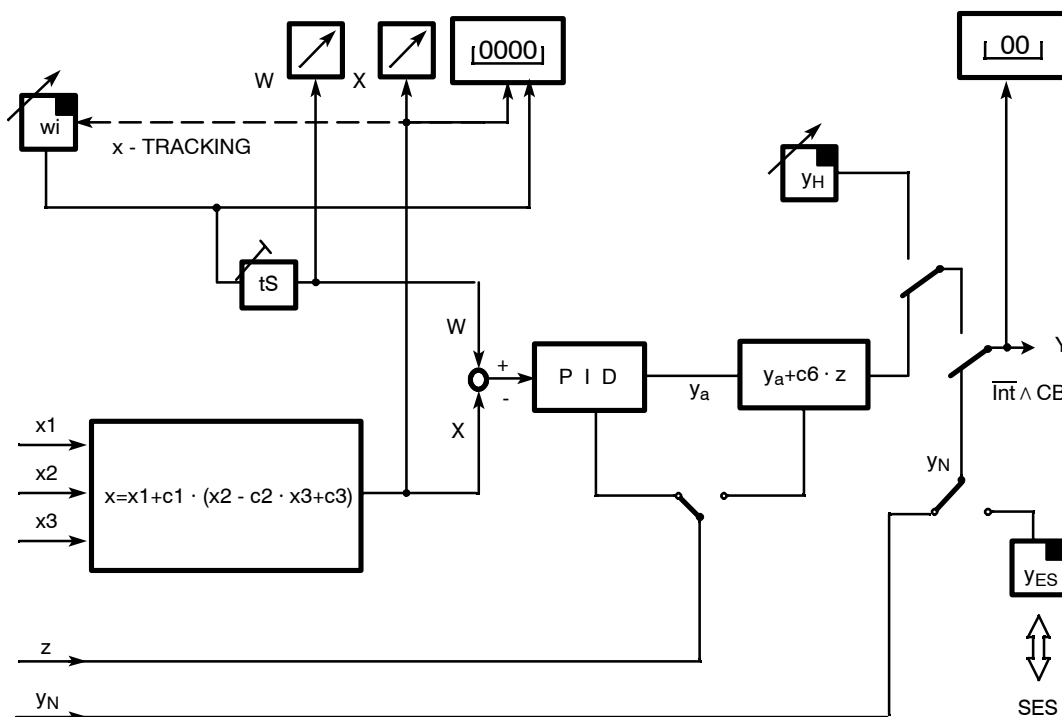

Figure 3-9 Control principle S1 = 2

The DDC-mode is signaled like the tracking mode in the other controller types by the lit  $y$ -External-LED. The status of the control signal CB and the Internal/External key is displayed by the LEDs  $\bar{C}$  and Internal. During the DDC-mode the setpoint is prepared by tracking to the computer failure. The setpoint is always displayed which would become active after the computer failure.

With S50 a choice is made between  $x$ -tracking and  $w_i$ , with S44 the safety setpoint is preset.

With S49 the priority between DDC-mode and manual mode is determined. If DDC-mode has priority over manual mode, you can select with the manual-automatic switching whether operation is to continue after a computer failure in automatic- or manual mode. If you need to intervene manually in computer operation, you have to switch to Internal-mode in addition to switching over to manual mode, then the LEDs Internal (17) and Manual (12) light up, the LED  $y$ -External (13) goes out, the non-lit LED  $\bar{C}$  (18) still indicates computer standby.

If manual mode has priority over DDC-mode you can switch directly from computer operation to manual operation. Then the Manual LED (12) lights, the  $y$ -External LED (13) goes out, the dark LEDs Internal (17) and  $\bar{C}$  (18) still indicate computer standby of the controller or computer standby.

Automatic mode is always switched to here in the event of a computer failure.

- **DDC-control unit**

The DDC-control unit function is obtained with S49 = 0 and with S51 = 2 (manual mode only). In computer operation the manipulated variable is fed through  $y_N$ , manual operation is always active after a computer failure. If you want to switch over to manual operation during computer operation, the computer operation must be switched off with the Internal key (16).

The actual value can be indicated on the actual value display.

SH as a flag pointer or  $w_i$  can be indicated on the setpoint display.

Digital inputs	Control signals		Message signals					Effective y	Effective w with				Explanations	Computer failure	
	Si	H 1)	CB3)	Front LED					S43=0 S44=0	S43=1 S44=0	S43=0 S44=1	S43=1 S44=1			
				Internal	C	H	y-external								Digital outp.
		Internal													
0	0	1	0	0	0	0	1	0	0	0	0	SH	SH	DDC mode, automatic mode prepared	
0	0	0	0	1	0	0	0	0	1	wi (n.)	wi (n.)	wi (n.)	wi (n.)	Automatic mode, computer switched off, controller ready	
0	0	1	1	0	0	0	0	1	1	wi (n.)	wi (n.)	wi (n.)	wi (n.)	Automatic mode, computer ready, controller not ready	
0	0	0	1	1	0	0	0	1	1	wi (n.)	wi (n.)	wi (n.)	wi (n.)	Automatic mode, computer switched off, controller not ready	
0	1	1	0	0	0.5 5)	0	1	0	0	wi (n.)	x	SH	x	DDC mode, manual mode ready	
0	1	0	0	1	1	0	0	1	1	wi (n.)	x	wi (n.)	x	Manual mode, computer switched off, controller ready	
0	1	1	1	0	1	0	0	1	1	wi (n.)	wi (n.)	wi (n.)	wi (n.)	Manual mode, computer ready, controller not ready	
0	1	0	1	1	1	1	0	1	1	wi (n.)	wi (n.)	wi (n.)	wi (n.)	Manual mode, computer switched off, controller not ready	
1	0	1	0	0	0	0	1	0	0	wi (n.)	x	wi (n.)	x	Safety mode, computer ready, controller ready	
1	0	0	0	1	0	0	1	0	1	wi (n.)	x	wi (n.)	x	Safety mode, computer switched off, controller ready	
1	0	1	1	0	0	0	1	1	1	wi (n.)	wi (n.)	wi (n.)	wi (n.)	Safety mode, computer ready, controller not ready	
1	0	0	1	1	0	0	1	1	1	wi (n.)	wi (n.)	wi (n.)	wi (n.)	Safety mode, computer switched off, controller not ready	
1	1	1	0	0	0.5 5)	0	1	0	0	wi (n.)	x	wi (n.)	x	Safety mode, computer ready, controller ready	
1	1	0	0	1	0.5 5)	1	0	1	1	wi (n.)	x	wi (n.)	x	Safety mode, computer switched off, controller ready	
1	1	1	1	0	0.5 5)	1	1	1	1	wi (n.)	wi (n.)	wi (n.)	wi (n.)	Safety mode, computer ready, controller not ready	
1	1	0	1	1	0.5 5)	1	1	1	1	wi (n.)	wi (n.)	wi (n.)	wi (n.)	Safety mode, computer switched off, controller not ready	

Footnote explanation, see page 72

Table 3-6 DDC controller, S1 = 2, manual operation has priority over DDC operation S49 = 1

Digital inputs		Control signals		Message signals					Effective y	Effective w with				Explanations	Computer failure
				Front LED		Digital outp.				S43=0 S44=0	S43=1 S44=0	S43=0 S44=1	S43=1 S44=1		
Si	H 1)	CB3)	Internal	Internal	C	H	y-external	RB4)	RC4)					wi (n,)	x
										0	0	1	0		
0	0	0	0	1	0	0	0	0	1	wi (n,)	wi (n,)	wi (n,)	wi (n,)	wi (n,)	wi (n,)
0	0	1	1	0	0	0	0	1	1	wi (n,)	wi (n,)	wi (n,)	wi (n,)	wi (n,)	wi (n,)
0	0	0	1	1	0	0	0	1	1	wi (n,)	wi (n,)	wi (n,)	wi (n,)	wi (n,)	wi (n,)
0	1	1	0	0	0	1	0.5 <sup>5)</sup>	0	0	wi (n,)	x	wi (n,)	wi (n,)	wi (n,)	x
0	1	0	0	1	1	1	0	0	1	wi (n,)	x	wi (n,)	wi (n,)	wi (n,)	x
0	1	1	1	0	1	0	0	1	1	wi (n,)	wi (n,)	wi (n,)	wi (n,)	wi (n,)	wi (n,)
0	1	0	1	1	1	1	0	1	1	wi (n,)	wi (n,)	wi (n,)	wi (n,)	wi (n,)	wi (n,)
1	0	1	0	0	0	0	1	0	0	wi (n,)	x	wi (n,)	wi (n,)	wi (n,)	x
1	0	0	0	1	0	1	0	0	1	wi (n,)	x	wi (n,)	wi (n,)	wi (n,)	x
1	0	1	1	0	0	0	1	1	1	wi (n,)	wi (n,)	wi (n,)	wi (n,)	wi (n,)	wi (n,)
1	0	0	1	1	1	0	1	1	1	wi (n,)	wi (n,)	wi (n,)	wi (n,)	wi (n,)	wi (n,)
1	1	1	0	0	0	0.5 <sup>5)</sup>	1	0	0	wi (n,)	x	wi (n,)	wi (n,)	wi (n,)	x
1	1	0	0	1	0.5 <sup>5)</sup>	1	0.5 <sup>5)</sup>	0	1	wi (n,)	x	wi (n,)	wi (n,)	wi (n,)	x
1	1	1	1	0	0.5 <sup>5)</sup>	1	0.5 <sup>5)</sup>	1	1	wi (n,)	wi (n,)	wi (n,)	wi (n,)	wi (n,)	wi (n,)
1	1	0	1	1	0.5 <sup>5)</sup>	1	0.5 <sup>5)</sup>	1	1	wi (n,)	wi (n,)	wi (n,)	wi (n,)	wi (n,)	wi (n,)

Footnote explanation, see page 72

Table 3-7 DDC controller, S1 = 2, manual operation has priority over DDC operation S49 = 1

**Notes to table 3-9 and table 3-7**

1) Manual operation can be achieved by:

Control signals		Message signals	
Digital input He	Front Hi	Front Manual LED	Digital output H
0	0	0	0
1	0	0,9 <sup>6)</sup>	1
0	1	1	1
1	1	1	1

Table 3-8 Generation of the control signal  $H = Hi \vee He$

2) In DDC-operation the setting current is switched off at  $S52 = 1$ . Source for  $y_E$  at  $S85 = 0, 1, (4, 5$  as of software version  $-A05)$ ,  $y$  is  $i_N$ . At  $S85 = 2, 3$ ,  $y$  acts  $ES$  (SES). The external manipulated variable fed in through the SES ( $y_{ES}$ ) is tracked. When feeding in via  $y_N$  the feeding instrument must be tracked.

3) The table is shown for static computer switching without acknowledgement,  $S41 = 0$ .

4) By OR-linking of the digital output H with the control signal  $S_i$  no computer standby or computer operation can be signaled in manual – or safety mode.

5) 0.5 = Flashing rhythm 1 : 1

6) 0.9 = Flashing rhythm 0.1 off, 0.9 on

(↗) = adjustable

(n) = is followed up to the value active before switching, therefore bumpless switching

The control signal Track (N) has no function in DDC-controllers. The tables apply for  $S45 = 0$  (with tracking of the inactive setpoint to the active setpoint). At  $S45 = 1$  (without tracking) and x-tracking, automatic operation starts with  $w_i = x$  ( $x_d = 0$ ), the active setpoint runs to the old set value  $w_i$  via the possibly set setpoint ramp  $t_S$ .



- **Display levels**

With the Shift key (6) the digital x/w-display can be switched between the display levels I to IV depending on the position of S81.

In display level II the active w can be displayed, in display level III the main control variable x1. The inactive setpoint is displayed in the display level IV. The displayed active or inactive setpoint can also be adjusted (see table 3-9).

The active setpoint- and actual value is displayed on the analog displays.

Structure switches	Position	Function				
S81	[0] 1 2 3 4 5 6 7	<b>Switching the w/x-digital display</b>				
		Display order				
		I	II	III	IV	
		x/xv	w/wv	-	-	
		x/xv	w/wv	x1/xv	-	
		x/xv	w/wi1/wv	-	wE/wvE/wi2	
		x/xv	w/wi1/wv	x1/xv	wE/wvE/wi2	
		x/xv	-	-	-	
		-	w/wv	-	-	
		-	-	x1/xv	-	
		xv	wv	x1	w	
		Identification of the displayed variables by the w- or x-signal lamp: 1 = steady light, 0.5 = flashing light, 0 = off				
Display order						
I	II	III	IV			
1	0	0.5 (0 at S81=6)	0			
0	1	0	0,5			

Table 3-9 Display levels (S81)

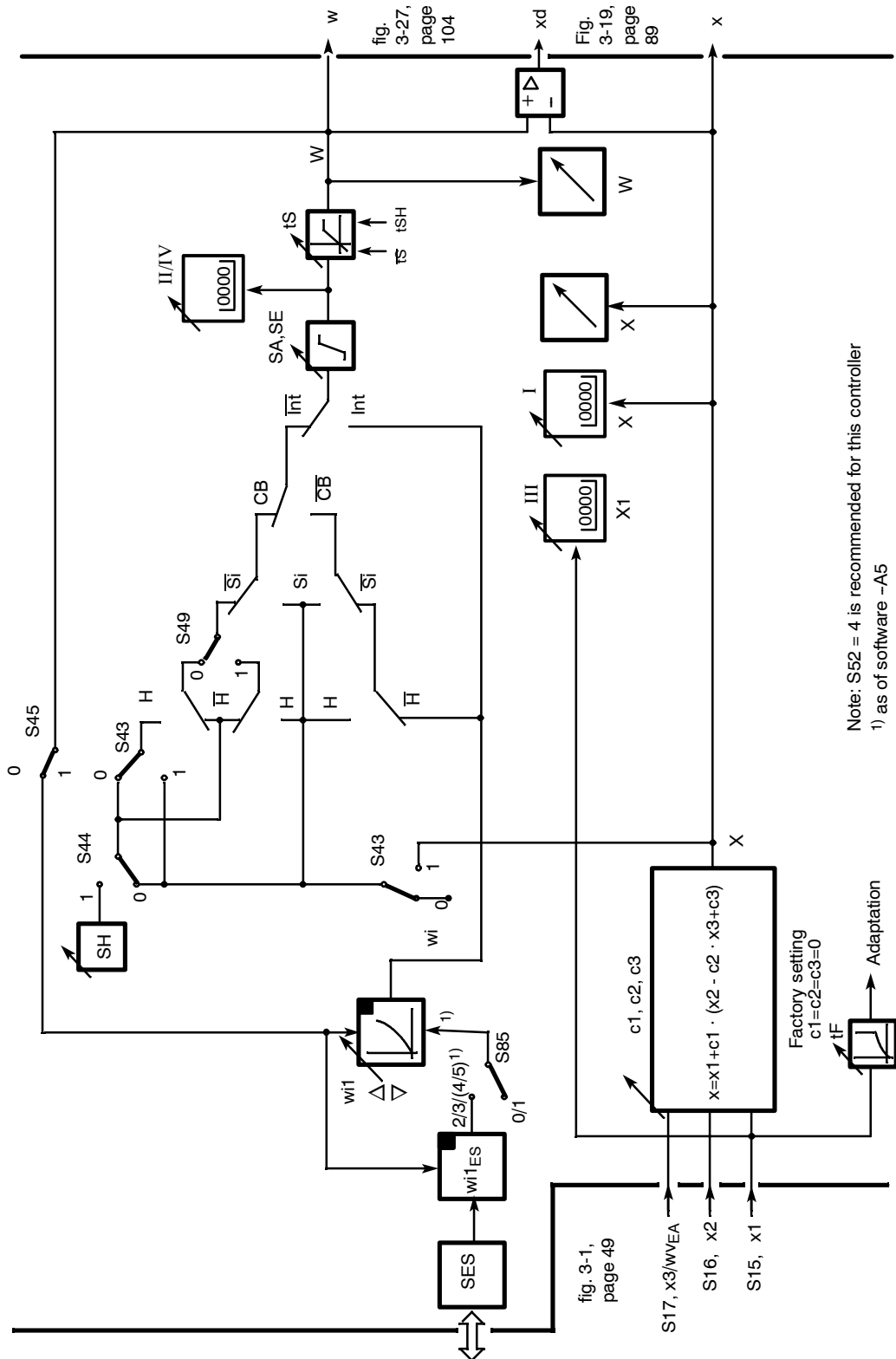

Figure 3-10 Block diagram S1 = 2, DDC fixed setpoint controller

### 3.4.5 Controlled ratio controller (S1 = 3)

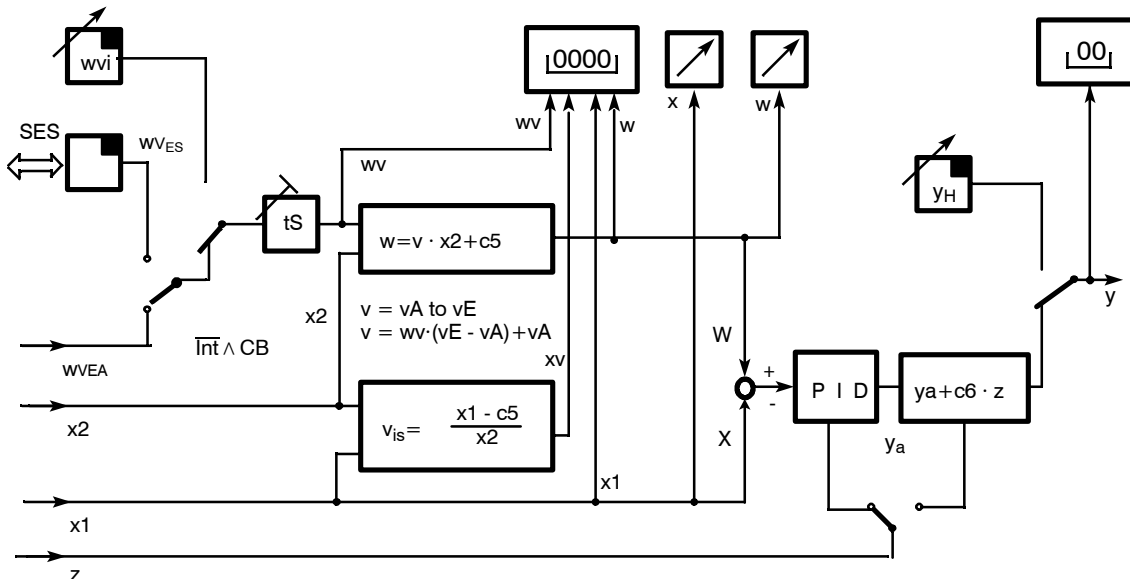

Figure 3-11 Control principle S1 = 3

In a ratio control the commanding process variable  $x_2$  is weighted with the adjustable ratio factor and a basic value  $c_5$  added if necessary. The result forms the setpoint  $w$  for the following controlled process variable  $x_1$ .

$$w = v \cdot x_2 + c_5$$

With  $xd = w - x_1$  the result is  $xd = v \cdot x_2 + c_5 - x_1$

In the controlled state ( $xd = 0$ ) the result is  $v = \frac{x_1 - c_5}{x_2}$ , i.e. in the controlled state and at  $c_5 = 0$   $\frac{x_1}{x_2}$  behaves according to the set ratio factor  $v$ .

A typical application are combustion rules where a fuel volume  $x_1$  belongs to every air volume  $x_2$  to guarantee optimum combustion.

The ratio factor range  $v = v_A$  to  $v_E$  is determined with the parameters  $v_A$  and  $v_E$  in the structuring mode oFPA in the range from 0.0 to 9.999 (factory setting  $v_A = 0$ ,  $v_E = 1$ ). In addition a basic value  $c_5$  (parameterization mode onPA) can be connected in the range from  $-1.999$  to 9.999 (factory setting = 0.0).

The standardized nominal ratio  $wv$  ( $wvi$  or  $wv_E$ ) in the range from 0 to 1 is converted to the ratio factor range.

$$v = wv (v_E - v_A) + v_A$$

With  $w = v \cdot x_2 + c_5$  the result is  $w = [wv (v_E - v_A) + v_A] x_2 + c_5$

In the ratio controller the standardized nominal ratio  $wv$  and the standardized actual ratio  $xv$  are displayed on the digital  $x/w$ -displays respectively in display levels I and II. A physical display is possible with dA, dE, dP. The controlled variable  $x_1$  and the evaluated commanding process variable  $w$  are displayed on the analog  $x$ - and  $w$ -displays respectively so that a direct control

difference monitoring is possible at all times. At S81 = 7, x1 and w can be displayed on the digital x/w-display in the levels III and IV. A physical display is possible with Pd, Ad, Ed.

At S81 = 2 or 3, the digital x/w-display can be switched to the external nominal ratio  $wv_E$  (display level IV). The digital x/w-display indicates the actual ratio xy in display levels I and III. Switching between wvi and  $wv_E$  takes place in the same way as in the slave controller S1 = 1.

The actual ratio is gained by back calculating the ratio formula with the current process variables x1, x2:

$$v_{is} = \frac{x1-c5}{x2}$$

with  $v_{ist} = xv (vE - vA) + vA$  the result is for  $xv = \frac{v_{is}-vA}{vE-vA}$  or  $xv = \frac{\frac{x1-c5}{x2} - vA}{vE-vA}$

xv is displayed and is required for x-tracking-mode. For the xv-display, x1 and x2 are limited to +0.5 % so that the display does not become too restless for small x1 and x2 or flip from positive to negative in the case of negative x2. The linearization of the commanding process variable x2 or the following process variable x1 is possible (S21).

The linearization then acts on the analog displays and the ratio formation and therefore indirectly on the digital displays for nominal- and actual ratio. The ratio controller has no nominal ratio limiting because the ratio factor range already marks the limit.

With the Shift key (6) the digital x/w-display can be switched between the display levels I to IV depending on the position of S81.

In display level II the active nominal ratio wy can be displayed, in display level I/III the actual ratio xy. The external setpoint  $wy_E$  is displayed in display level IV. The displayed active or external nominal ratio can also be adjusted.

The active setpoint- and actual value is displayed on the analog displays (see table 3-10).

Structure switches	Position	Function			
S81	[0] 1 2 3 4 5 6 7	<b>Switching the w/x-digital display</b>			
		Display order			
		I	II	III	IV
		x/xv	w/wv	-	-
		x/xv	w/wv	x1/xv	-
		x/xv	w/wi1/wv	-	wE/wvE/wi2
		x/xv	w/wi1/wv	x1/xv	wE/wvE/wi2
		x/xv	-	-	-
		-	w/wv	-	-
		-	-	x1/xv	-
		xv	wv	x1	w
		Identification of the displayed variables by the w- or x-signal lamp: 1 = steady light, 0.5 = flashing light, 0 = off			
Display order					
I	II	III	IV		
1	0	0.5 (0 at S81=6)	0		
0	1	0	0,5		
			x-signal lamp		
			w-signal lamp		

Table 3-10 Display levels (S81)

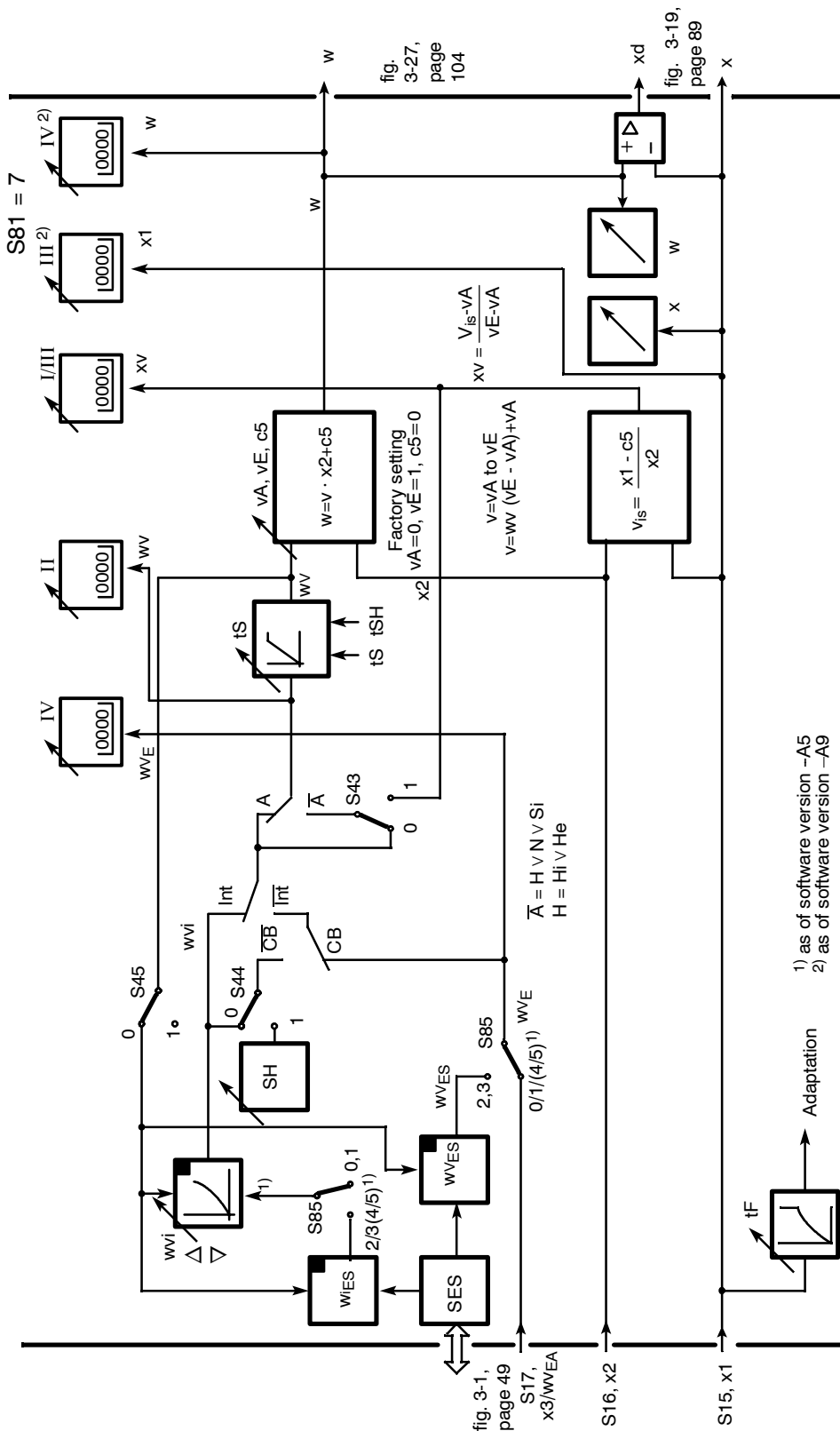

Figure 3-12 Block diagram S1 = 3 controlled ratio controller

The ratio controller behaves like the slave controller S1 = 1 with respect to switching of the set-point ratio  $wv$  so that the information and tables there apply accordingly. The variables  $w_i$  and  $w_E$  must be replaced by  $w_{vi}$  and  $w_{vE}$ . This controller type can also be used as a ratio controller with fixed ratio (manually adjustable) or with commanded ratio factor.

A fixed ratio factor is used for example in simple combustion rules, (see example) where the ratio factor is reset manually if necessary for varying fuels. If it is possible to measure the effects of the ratio factor (combustion quality, pollutants in the flue gas) a commanded ratio controller is used. Here a master controller adjusts the ratio factor (ratio cascade) with the combustion quality as a control variable.

Another application for ratio cascades are concentration controls, e.g. pH-value-controls. The pH-value is the controlled variable of the command controller, the flow of alkali and acid the commanded process variable and the following (controlled) process variable of the ratio controller.

● **Example of a ratio control**

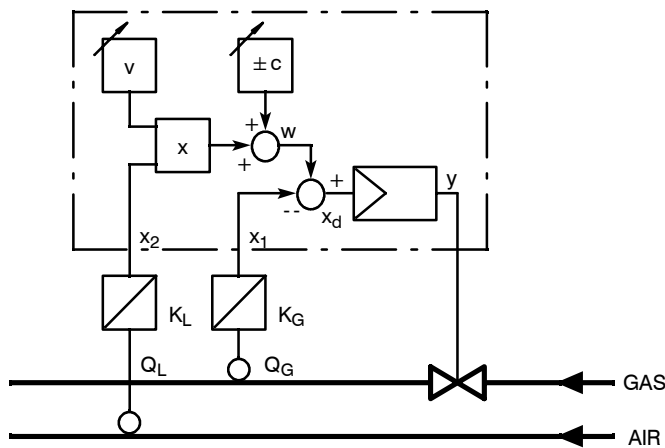

Figure 3-13 Control diagram ratio control

In a combustion control the air-/gas flow should be in a constant ratio. The command variable (commanding process variable) is the air flow  $Q_L$  which is preset in the range 0 to 12000 m<sup>3</sup>/h as a signal 4 to 20 mA. The controlled variable (following process variable) is the gas flow  $Q_G$  with a measuring range 0 to 3000 m<sup>3</sup>/h which is also available as a 4 to 20 mA signal. In an ideal combustion the air-/gas ratio is

$$L_{\emptyset ideal} = \frac{Q_L}{Q_G} = 4.$$

$\frac{Q_L}{Q_G} = L_{\emptyset} \cdot \lambda$  The air factor  $\lambda$  is then 1 and should be adjustable in the range from 0.75 to 1.25 on the controller.

The ratio factor  $v$  (at  $x_d = 0$ ) is determined partly by the transmission factors  $K$  of the transmitters (measuring ranges).

$$x_1 = Q_G \cdot K_G \quad \text{with the values from the example} \quad K_G = \frac{100\%}{3000 \text{ m}^3/\text{h}}$$

$$x_2 = Q_L \cdot K_L \quad K_L = \frac{100\%}{12,000 \text{ m}^3/\text{h}}$$

$$v = \frac{x_1}{x_2} = \frac{Q_G}{Q_L} \cdot \frac{K_G}{K_L} \quad \text{with} \quad \frac{Q_G}{Q_L} = \frac{1}{L_0 \cdot \lambda}$$

$$v = \frac{1}{L_0 \cdot \lambda} \cdot \frac{K_G}{K_L}$$

With the values from the example

$$v = \frac{1}{\lambda} \cdot \frac{1}{4} \cdot \frac{100\% \cdot \text{h} \cdot 12,000 \text{ m}^3}{3,000 \text{ m}^3 \cdot 100\% \cdot \text{h}}$$

the result is  $v = \frac{1}{\lambda}$  i.e. the choice of the transmitter ranges has been made so

that  $\frac{K_G}{K_L} = \frac{1}{L_0}$  corresponds to

The desired adjustment range of  $\lambda$  gives:

$$v_A = \frac{1}{\lambda_E} = \frac{1}{1,25} = 0,8 \quad v_E = \frac{1}{\lambda_A} = \frac{1}{0,75} = 1,333$$

$v_A$  and  $v_E$  are set in the structuring mode oFPA. By setting the nominal ratio  $wv$  from 0 to 1 the ratio factor  $v$  can now be adjusted from 0.8 to 1.33 or the air factor  $\lambda$  from 1.25 to 0.75.

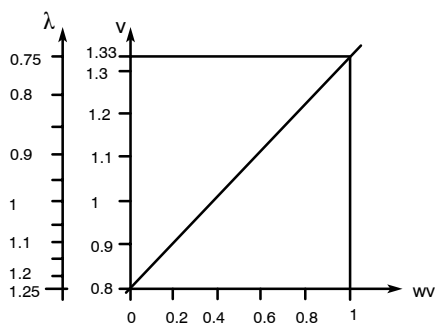

Figure 3-14 Relationship ratio factor  $v$  and air factor  $\lambda$  to standardized nominal ratio  $wv$

If the combustion is also to take place at small flow volumes with excess air, the constant  $c$  must be set negative. Figure 3-14 shows the gas-/air ratio in the controlled state at different air factors  $\lambda$  and  $c = 0$  as well as at  $\lambda = 1$  and  $c < 0$ , i.e. with excess air.

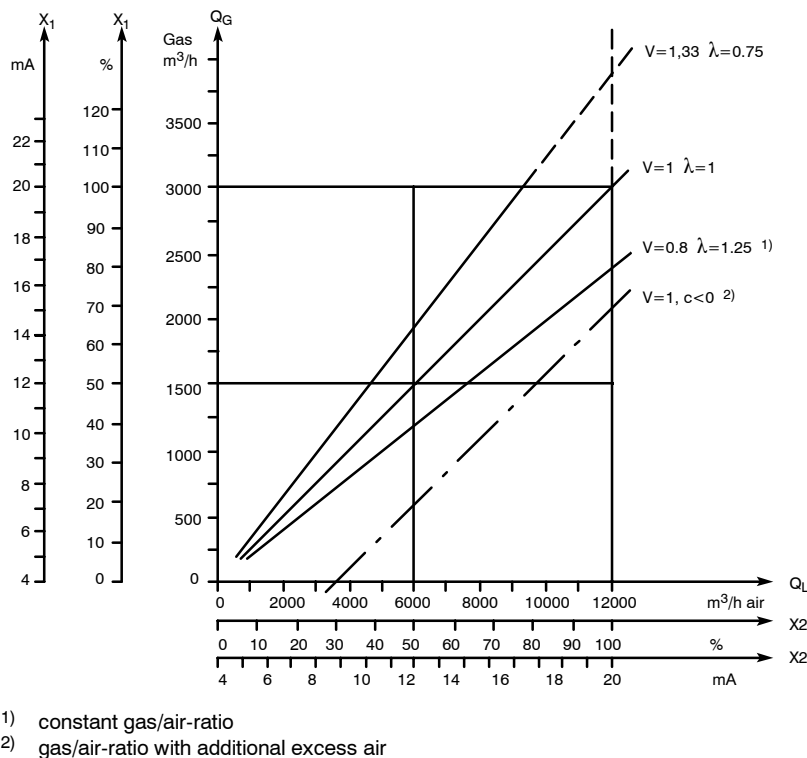

Figure 3-15 Display of gas-/air ratio in controlled status

### 3.4.6 Control unit/process display (S1 = 4)

The following functions are possible in this configuration:

Process display and control unit. The configuration is identical for both applications. The input wiring for both is illustrated in figure 3-16, page 82.

- **Process display, two-channel analog display with parallel, switchable digital display (S85 = 0/1 and S42 = 1)**  
 see figure 3-16, page 82

The process variables are assigned to the green analog display by  $w_{EA}$  and to the red analog display by  $x_2$ .

The display range of the analog display is 0 to 100 %. The four-digit digital x/w-display is connected in parallel to the analog display by the Shift key (6) to the positions I and II one after another.

The display range of the digital display is set for both display positions together with the parameters  $dA$ ,  $dE$ ,  $dP$  in the oFPA configuring mode. The linearizer (S21) which can be assigned to the analog input then acts on both the analog- and the digital display. If this is not desirable, the linearizer can also be assigned to  $x_1$  by  $S21 = 5$  and connect the same analog



input (AI1 to AI4) by S15 (x1) and S16 (x2). In this case the unlinearized process variable is displayed in display order position II and the linearized process variable in position III.

Of course it is also possible to use the x1-display channel separately from the two analog displays as a third display channel.

Another display channel is available with the two-digit y-display via  $Y_R$ .

- **Process display, one-channel analog display with parallel, digital display and displayed limit values**

see fig. 3-16, page 82

The red analog display is fed via x2, a parallel physical digital display is possible by assigning x1 via S15 to the same analog input if the linearizer is assigned to x1 by S21 = 5 and the display range is set by dA, dE to oFPA-mode.

Of course it is also possible to use the x1-display channel separately from the two analog displays as a second display channel.

A third display channel is available with the two-digit y-display via  $y_R$ .

Via S80 = 5/6 the limit values A1, A2 or A1 to A4 can be displayed on the green analog display with a resolution of 3 %. When assigning the limit values to the displayed process variable in the red analog display, the position of the process variable to the limit values can be read. If a limit value responds, this is signaled by the corresponding alarm lamp (20) and the flashing alarm-LED on the green bargraph. The alarms can be labeled on the replaceable scale (21).

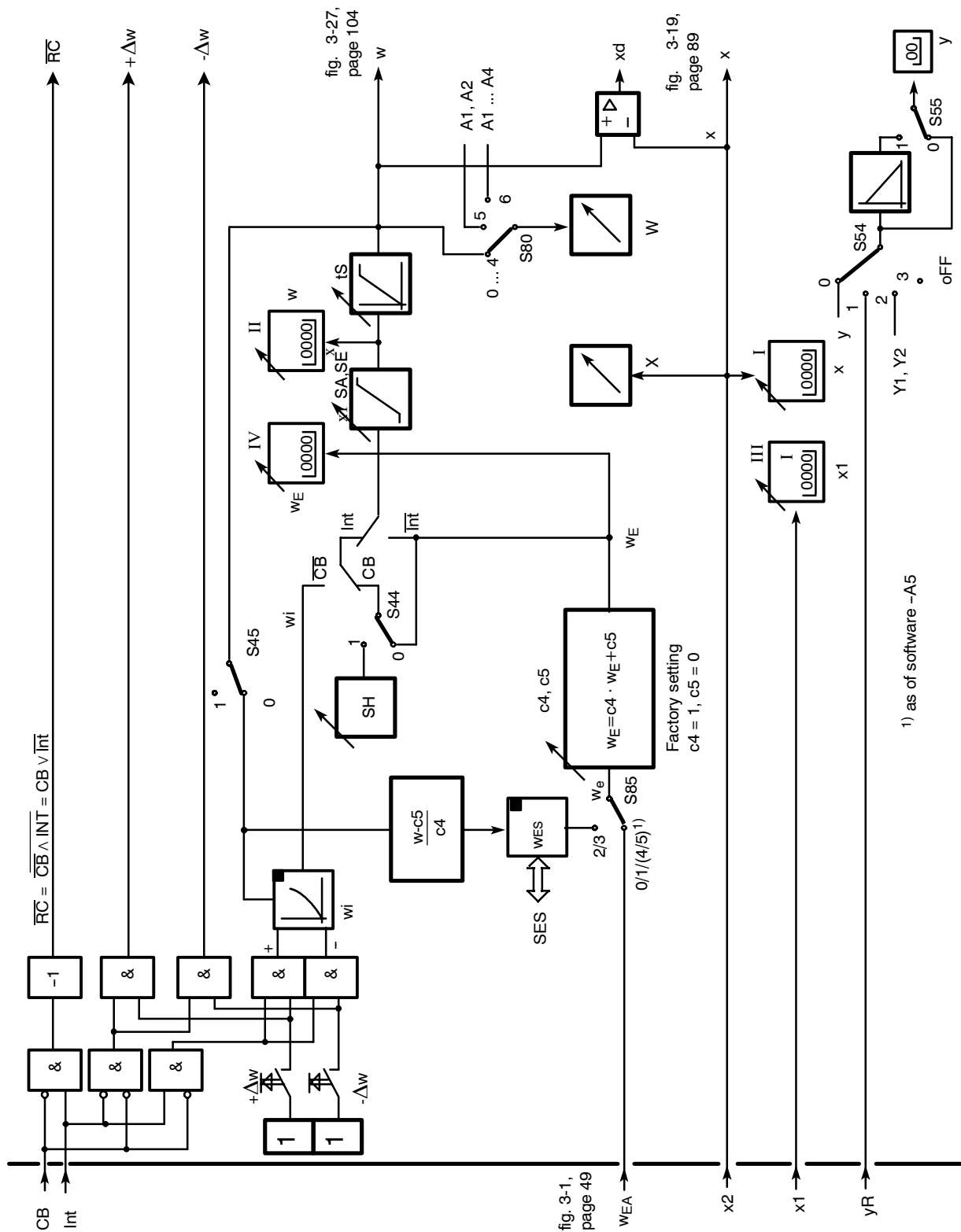

Figure 3-16 Block diagram control unit/process display (S1 = 4) setpoint generator S/K, manual control station S/K

- **Control units**

The integrated control unit function always includes a setpoint generator and a manual control station in the following versions:

- trackable K-setpoint generator
- S-setpoint generator
- trackable K-manual control station (S2 = 0)
- S-two-position control unit with 2 outputs (heating/cooling) (S2 = 1)
- S-three-position manual control unit internal feedback (S2 =2)
- S-three-position manual control unit external feedback (S2 =3)

The ability to combine setpoint generator- and manual control station type depends on the application. Either the setpoint generator or the manual control station can use the K-output, the remaining function must have an S-output.

- **Setpoint generator** see figure 3-16, page 82

S- and K-setpoint generators are installed parallel. In the S-setpoint generator, the switching outputs  $\pm \Delta w$  can be locked depending on the Internal key (16) and the control signal CB, the status message is output by the signal lamps Int and C, see table 3-7, page 71. The feedback of the setpoint adjusted incrementally by the switching outputs takes place via the w-display (input  $w_{EA}$ , the switching is blocked in position Ext, S42 = 1).

In the K-setpoint generator the tracking of the internal setpoint is controlled dependent on the Internal key (16) and the control signal CB, see table 3-7, page 71. The tracking variable is fed in via  $w_{EA}$ . The active setpoint is output by assignment of w to the analog output AO (S56 = 2/3).

With the Shift key (6) the digital x/w-display can be switched between the display levels I to IV depending on the position of S81. The controlled variable is displayed in the display level I. In display level II the active w can be displayed, in display level III the controlled variable x1. The inactive setpoint is displayed in the display level IV. The displayed active or external setpoint can also be adjusted (see table 3-11, page 84).

The active setpoint- and actual value is displayed on the analog displays.

Structure switches		Position	Function				
S81		[0] 1 2 3 4 5 6 7	<b>Switching the w/x-digital display</b>				
			Display order				
			I	II	III	IV	
			x/xv	w/wv	-	-	
			x/xv	w/wv	x1/xv	-	
			x/xv	w/wi1/wv	-	wE/wvE/wi2	
			x/xv	w/wi1/wv	x1/xv	wE/wvE/wi2	
			x/xv	-	-	-	
			-	w/wv	-	-	
			-	-	x1/xv	-	
xv	wv	x1	w				
Identification of the displayed variables by the w- or x-signal lamp: 1 = steady light, 0.5 = flashing light, 0 = off							
Display order							
I	II	III	IV	x-signal lamp w-signal lamp			
1	0	0.5 (0 at S81=6)	0				
0	1	0	0,5				

Table 3-11 Display levels (S81)

Control signals		Message signals				active w at		Effect of the $\pm \Delta w$ -keys on		wired or Int $\vee$ CB
Digital in-puts	Front	Front		Digital outputs		S44=0	S44=1	wi	$\pm \Delta w/BA$	
CB <sup>1)</sup>	Internal	Internal LED	$\overline{C}$ LED	$\overline{RB}$	$\overline{RC}$ <sup>5)</sup>					
0	0	0	1	0	1	<sup>3)</sup> we(n) <sup>2)</sup>	<sup>3)</sup> we(n) <sup>2)</sup>	no	yes	0 <sup>7)</sup>
1	0	0	0	0	1	<sup>3)</sup> we(n) <sup>2)</sup>	<sup>3)</sup> we(n) <sup>2)</sup>	no	no	1
0	1	1	1	1	0	<sup>3)</sup> wi(n, <sup>↗</sup> )	<sup>3)</sup> wi(n, <sup>↗</sup> )	yes	no	1
1 <sup>6)</sup>	1 <sup>6)</sup>	1 <sup>6)</sup>	0 <sup>6)</sup>	1 <sup>6)</sup>	1 <sup>6)</sup>	<sup>3)</sup> we(n) <sup>2)6)</sup>	SH <sup>4)6)</sup>	no <sup>6)</sup>	no <sup>6)</sup>	1 <sup>6)</sup>

- 1) The table is shown for static CB-switching without acknowledgement (S41 = 0).
- 2) Source for  $w_E$  at S85 = 0, 1, (4, 5 as of software version -A5), is  $w_{EA}$ , which is assigned by S17 or at S85 = 2, 3  $w_{ES}$ , which is fed in via the SES.
- 3) Tracking only takes place at S45=0 and only  $w_{ES}$  and  $w_i$  to the active setpoint. When feeding in via  $w_{EA}$  the feeding instrument must be tracked.
- 4) Only to be used as a flag pointer when no analog feedback is possible from the fed instrument.
- 5)  $\overline{RC}$  = no K-setpoint generator operation,  $w_i$  not adjustable.
- 6) Factory setting
- 7) wired-or-connection of Int =  $\overline{RB}$  and CB supplies Int  $\vee$  CB  
 No S-setpoint optentiometer operation,  $\Delta w$ -keys not active
- (n) tracked to the value active before switching, therefore bumpless switching
- <sup>↗</sup> adjustable

Table 3-12 Setpoint switching setpoint generator S/K, S1 = 4 process display/control unit

- **Manual control station (S2 = 0, 1, 2, 3)**

see figure 3-17, page 86 and figure 3-18, page 87

The controller output structures which can be configured by S2 are used for the manual control station function whereby automatic operation is replaced by the "Hold manipulated variable" mode. All other operating modes are identical with the controller functions. The last manipulated variable before switching to this operating mode is transferred to this hold operation and the  $\pm \Delta y$ -keys are inactive. If, in this operating mode, the manipulated variable output is to be tracked e.g. in 2-wait operation, the tracking operation must be activated by the control signal N and the input yN.

If only manual control function without switching is desired, the instrument must be blocked in manual mode with S51 = 2.

The following figures only show 2 examples. For the other variations, see the block diagrams of the controller-output structures (fig. 3-22, page 96, figure 3-23, page 97 and figure 3-25, page 100 to figure 3-28, page 105).

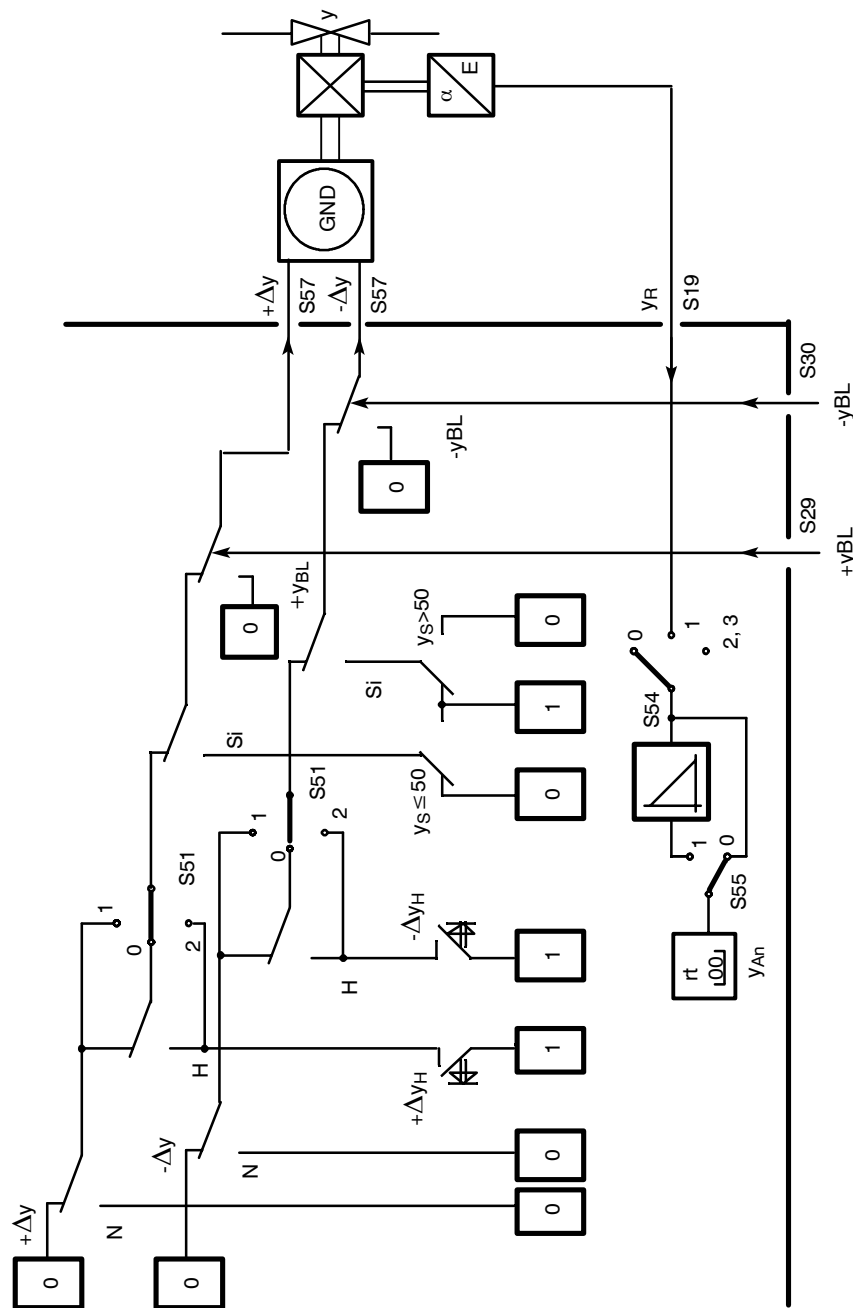

Block diagrams for S49 = 0 and manual control station S with ext. feedback (S2=3) see controller output structures figure 3-27, page 104

Figure 3-17 Block diagram control unit/process display (S1 = 4) manual control station S with internal feedback S2 = 2 (manual operation has priority over tracking S49 = 1)

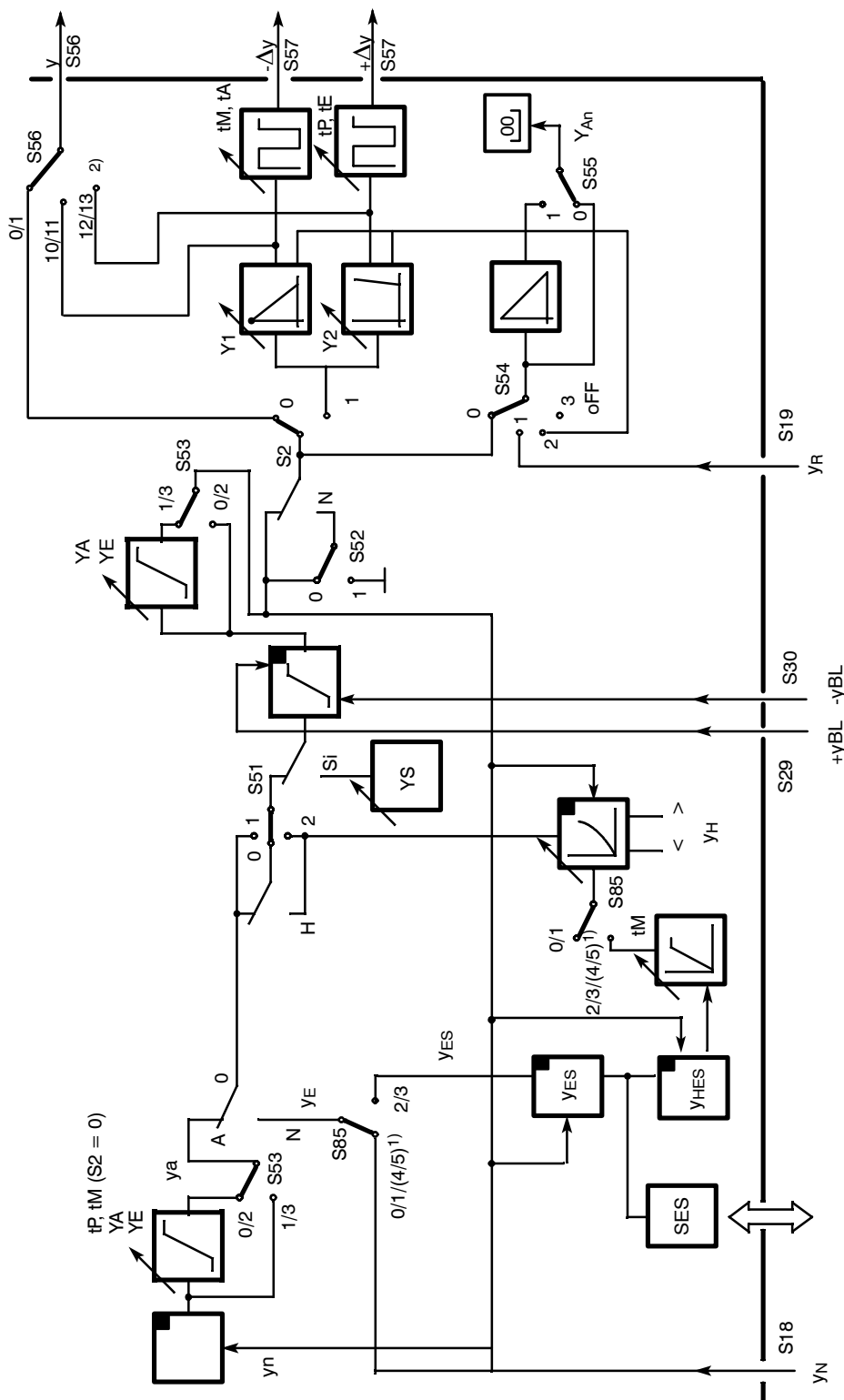

1) as of software version -A5  
2) as of software version -B2

Block diagram for S49 = 0, see controller output structures figure 3-28, page 105

Figure 3-18 Block diagram control unit/process display (S1 = 4) manual control station with K-output  
S2 = 0/two-position output S2 = 1 (manual operation has priority over tracking S49 = 1)

Control signals					Message signals				active y at	Explanations
Digital inputs				Front	Front		Digital outputs			
$\pm y_{BL}$	Si	N	Hi <sup>7)</sup>	Hi <sup>8)</sup>	H LED	y-Ext. LED	H	Nw		
0	0	0	0	0	0	0	0	0	$y_a(n)$	Hold operation
0	0	0	1	0	0,9 <sup>4)</sup>	0	1	0	$y_H(n, \nearrow)$	Manual mode
0	0	0	0	1	1	0	1	0	$y_H(n, \nearrow)$	Manual mode
0	0	0	1	1	1	0	1	0	$y_H(n, \nearrow)$	Manual mode
0	0	1	0	0	0	1	0	1	$y_E(n)^{1)}$	Tracking operation
0	0	1	1	0	0,5 <sup>5)</sup>	1	1	1	$y_E(n)$	Tracking operation
0	0	1	0	1	0,5 <sup>5)</sup>	1	1	1	$y_E(n)$	Tracking operation
0	0	1	1	1	0,5 <sup>5)</sup>	1	1	1	$y_E(n)$	Tracking operation
1	0	as above			0,5 <sup>5)6)</sup>	1	as above	0	$\pm y_{BL}^{2)}$	$\pm$ Blocking operation
1	1	as above			0,5 <sup>5)6)</sup>	1	as above	0	$\pm y_{BL}^{2)}$	$\pm$ Blocking operation
0	1	as above			0,5 <sup>5)6)</sup>	1	as above	0	$y_S^{3)}$	Safety operation

Table 3-13 Output switching manual control station S/K (S1 = 4)  
 Tracking operation has priority over manual operation (S49 = 0)

Control signals					Message signals				active y at	Explanations
Digital inputs				Front	Front		Digital outputs			
$\pm y_{BL}$	Si	N	Hi <sup>7)</sup>	Hi <sup>8)</sup>	H LED	y-Ext. LED	H	Nw		
0	0	0	0	0	0	0	0	0	$y_a(n)$	Hold operation
0	0	0	1	0	0,9 <sup>4)</sup>	0	1	0	$y_H(n, \nearrow)$	Manual mode
0	0	0	0	1	1	0	1	0	$y_H(n, \nearrow)$	Manual mode
0	0	0	1	1	1	0	1	0	$y_H(n, \nearrow)$	Manual mode
0	0	1	0	0	0	1	0	1	$y_E(n)^{1)}$	Tracking operation
0	0	1	1	0	0,9 <sup>4)</sup>	0,5	1	1	$y_H(n, \nearrow)$	Manual mode
0	0	1	0	1	1	0,5 <sup>5)</sup>	1	1	$y_H(n, \nearrow)$	Manual mode
0	0	1	1	1	1	0,5	1	1	$y_H(n, \nearrow)$	Manual mode
1	0	as above			0,5 <sup>5)6)</sup>	1	as above	0	$\pm y_{BL}^{2)}$	$\pm$ Blocking operation
1	1	as above			0,5 <sup>5)6)</sup>	1	as above	0	$\pm y_{BL}^{2)}$	$\pm$ Blocking operation
0	1	as above			0,5 <sup>5)6)</sup>	1	as above	0	$y_S^{3)}$	Safety operation

- 1) Source for  $y_E$  at S85 = 0, 1, (4, 5 as of software version -A5),  $y_{iN}$  as an absolute value assigned via S18. At S85 = 2, 3,  $y_{ES}$  via the SES. The external manipulated variable through which SES ( $y_{ES}$ ) is fed in is tracked. When feeding in via  $y_N$  the feeding instrument must be tracked. At S-output with internal feedback, a  $y_E$ -selection is not possible, here the last y before switching is held.
  - 2) Blocking operation acts direction-dependently, changes to the opposite direction are possible.
  - 3) Function  $y_E$  in S-controllers with internal feedback (S2 = 1) drive open- or closed otherwise parameterizable safety setting value.
  - 4) 0.9 flashing rhythm 0.1 off, 0.9 on
  - 5) 0.5 = flashing rhythm 1:1
  - 6) only if HiHe = 1
  - 7) for S51  $\neq$  3,4
  - 8) As of software version -A7 the signals He<sub>DI</sub> and He<sub>ES</sub> with S51 = 3, 4 have dynamic effect (0/1-edge). They then act like the Hi-signal (see figure 3-3, page 53)
- (n) tracking takes place to the value active before switching, therefore bumpless switching  
 $\nearrow$  adjustable

Table 3-14 Output switching manual control station S/K (S1 = 4)  
 Manual operation has priority over tracking operation (S49 = 1)



**3.4.7 Fixed setpoint controller with one setpoint (control system coupling)**  
(S1 = 5) <sup>1)</sup>

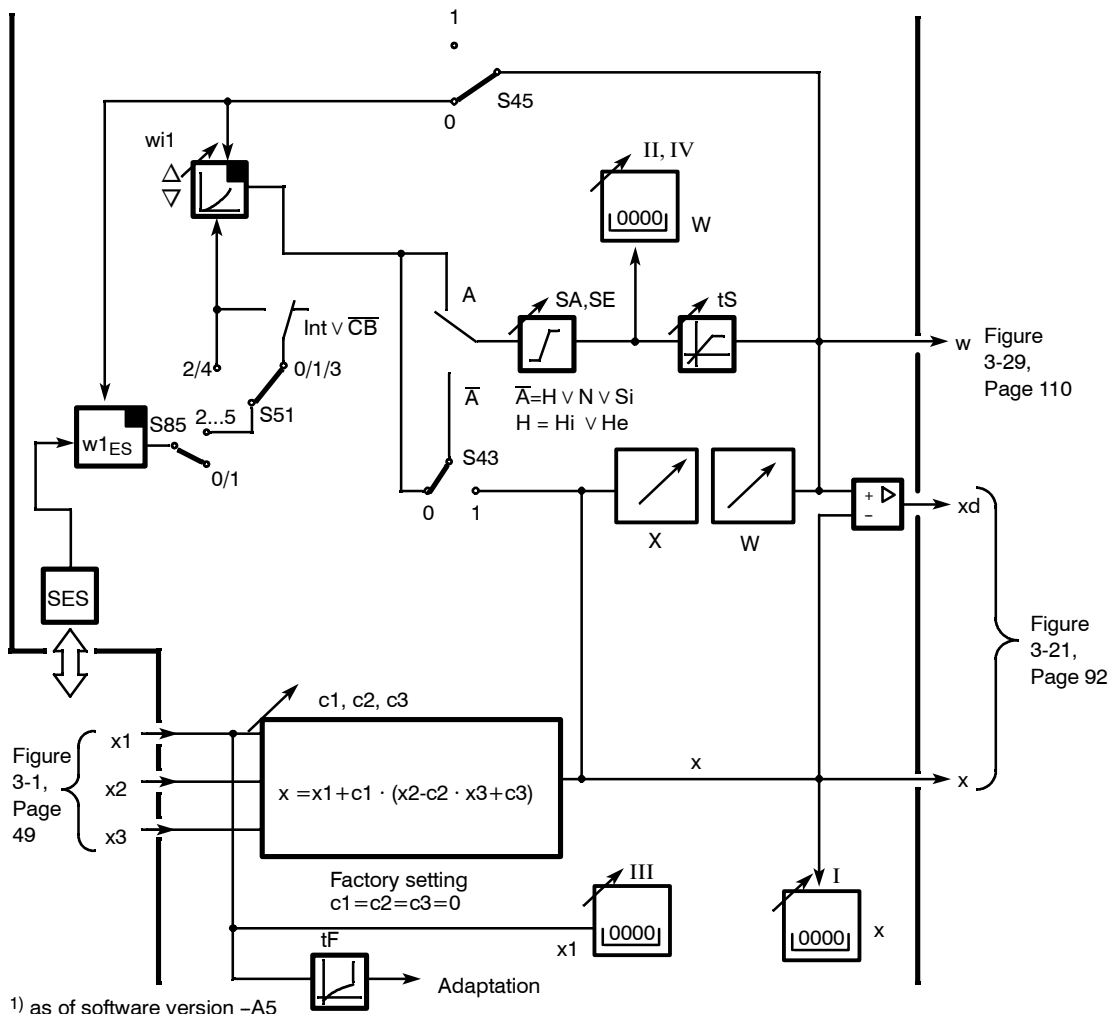

Figure 3-19 Block diagram S1 = 5, fixed setpoint controller with one setpoint for control system coupling

This fixed setpoint controller is designed specially for coupling to the control system. The control interventions by signals Int and CB are available for locking the control system operation via SES. With Int v CB the setpoint signal w<sub>ES</sub> is separated and manual intervention via H<sub>eES</sub> at S51 = 3 is suppressed.

The other wiring of the input function is almost identical with the structure S1 = 0 (see chapter 3.4.2, page 59). (Due to the control system control possible at S1 = 5, only an internal setpoint can be implemented here)

S51 = 3 is expressly recommended for this connection.

### 3.4.8 Slave controller without Int/Ext -switching (control system coupling) (S1 = 6) <sup>1)</sup>

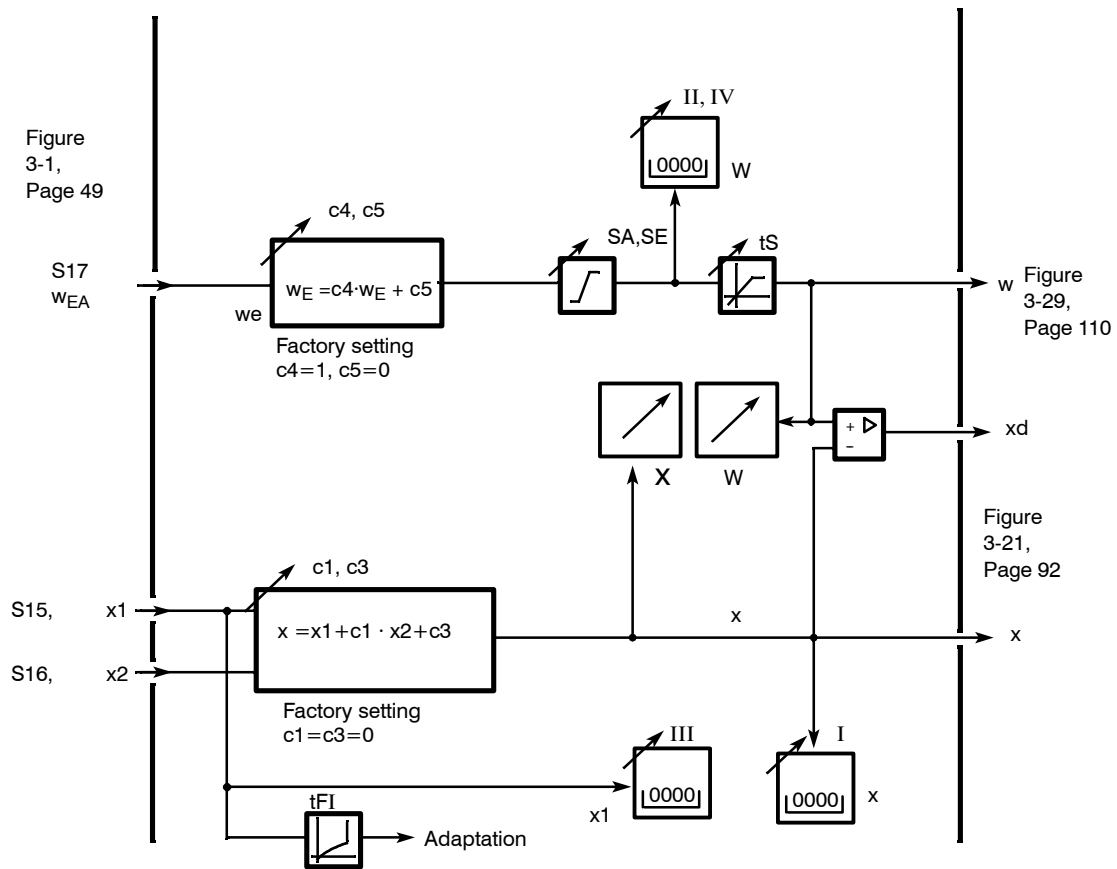

<sup>1)</sup> as of software version -A5

Figure 3-20 Block diagram S1 = 6, slave controller for control system coupling

This slave controller is designed specially for the control system coupling. It differs from the structure S1 = 1 (see chapter 3.4.3, page 62) in that the setpoint switching to via Int and CB is omitted and thus these control signals are available for locking the control system operation via the SES. With Int  $\vee$   $\overline{CB}$  manual intervention via He<sub>ES</sub> at S51 = 3 is suppressed.

The other functions are unchanged in relation to S1 = 1. S51 = 3 is expressly recommended for this connection.

## 3.5 Control algorithm

### • Control algorithm

The PID-control algorithm is implemented as an interaction-free parallel structure and follows the ideal controller equations whilst neglecting the filter constants and the cycle time.

#### - P-controller

$$y_a = \pm K_p \cdot x_d + y_o \quad \text{or} \quad \frac{y_a}{x_d} = \pm K_p$$

#### - PI-controller

$$y_a = \pm K_p \left( x_d + \frac{1}{T_n} \int_0^t x_d dt \right) + y_o(t) \quad \text{or} \quad \frac{y_a}{x_d} = \pm K_p \left( 1 + \frac{1}{j\omega \cdot T_n} \right)$$

#### - D-element connection (zD-part)

The D-element connection can be added optionally.

$$\frac{y_a}{E} = \pm K_p \frac{j\omega \cdot T_V}{1 + j\omega \cdot \frac{T_V}{V}}$$

The input variable E for the D element is  $x_d$ ,  $x$ ,  $x_1$ ,  $-z$ , or  $+z$  depending on the setting of S47.

#### - z-connection

The z-part can be added optionally to the controller output  $y_a$ .

$$y_a = \pm c_6 \cdot z \quad \text{or} \quad \frac{y_a}{z} = \pm c_6$$

### • Controller direction of effect

The controller direction of effect is set with S46. It must always have the opposite behavior (negative follow-up) to the controlled system (including final control element and transmitter).

S46= 0, normally acting controller (+K<sub>p</sub>, rising x causes falling y) for normally acting systems (rising y causes rising x)

S46=1, reversing controller (-K<sub>p</sub>, rising x causes rising y) for reversing systems (rising y causes falling x).

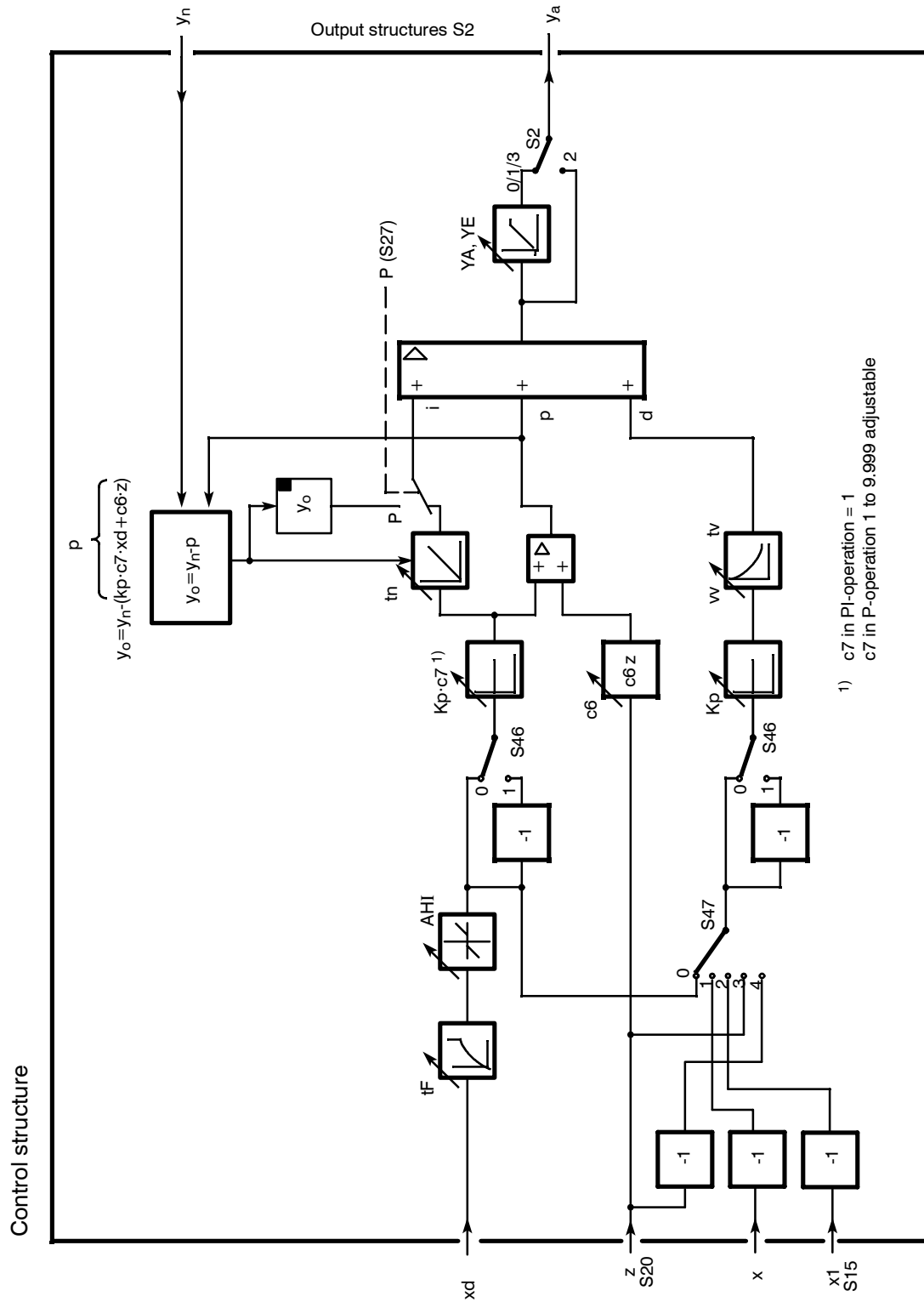

Input signal processing figure 3-1, page 49 and controller types S1

Figure 3-21 Block diagram controller structure

- **Operating point  $y_o$  for P-controllers**

The operating point  $y_o$  of the P-controller can be set either automatically or as a parameter (onPA).

**Automatic working point ( $Y_o = \text{Auto}$ )**

Whenever there is no automatic operation (manual-, tracking-, safety- or blocking operation) the operating point  $y_o$  is tracked so that switching to automatic operation is bumpless. This gives an automatic setting of the operating point  $y_o$  in manual mode:

$$y_o = y_H - (K_p \cdot c_7 \cdot (w - x_H) + c_6 \cdot z)$$

If the actual value in manual mode ( $x_H$ ) is driven to the desired setpoint  $w$  by the appropriate manual manipulated variable  $y_H$ , the operating point  $y_o$  is identical to the manual manipulated variable  $y_H$ .

$$y_o = y_H \text{ or } y_o = y_H + c_6 \cdot z.$$

**Fixed working point ( $Y_o = 0 \text{ to } 100 \%$ )**

The controller operates in all operating modes with the working point set as a permanent parameter.

- **manipulated variable limit YA, YE**

The manipulated variable limit with the parameters YA and YE is only active in automatic operation or in all operating modes depending on the switch position of S53. The limits of these parameters are at -10 and +110 %. However, it should be taken into account that the controller neither outputs negative actuating currents nor detects any negative position feedback signals.

If the manipulated variable  $y_a$  reaches one of the limits YA or YE in the limited operating mode, further integration is aborted to avoid integral saturation. This ensures that the manipulated variable can be changed immediately after reversing the polarity.

In manual-, tracking-(DDC) or safety operation, the manipulated variable  $y$  at S53 = 0 (limiting only in automatic operation) can be driven out of the limiting range. When switching to automatic operation the last manipulated variable is then transferred bumplessly but only changes in the manipulated variable in the direction of the YA to YE range are subsequently executed.

The manipulated variable limiting is possible at K-, two-position-and three-position-stepper-controllers with external position feedback (S2 = 0, 1, 3).

- **Bumpless switching to automatic mode**

If there is no automatic operation (manual-, tracking, safety- or active blocking operation) the I-part or the operating point  $y_o$  (only at  $Y_o = \text{Auto}$ ) is tracked so that the switching to automatic operation is bumpless. Any still active D-part is set to zero.

- **P-PI-switching**

With the control signal  $P = 1$ , the controller is switched from PI-to P-behavior, at  $Y_o = \text{Auto}$ , the switching is bumpless.

### 3.6 Controller output structures (S2, S49 to S55)

The controller structures follow four different controller output structures depending on structure switch S2.

S2=0	K-controller
S2=1	Two-position controller with 2 S-outputs heating/cooling, optionally one K-output
S2=2	S-controller with internal feedback
S2=3	S-controller with external feedback

- **S2=0: continuous (K) controller** (figure 3-22, page 96 and figure 3-23, page 97)

To control proportional active actuators (e.g. pneumatic actuators or I/P-transformers) or as command controllers in cascades.

**actuating time  $t_P, t_M$  (onPA)**

The setting speed of the automatic manipulated variable is set with the parameters  $t_P$  and  $t_M$ . In the oFF position, no limiting takes place, in positions 1 to 1000 s the minimum actuating time for 0 to 100 % manipulated variable is preset. Whereby  $t_P$  acts during increase and  $t_M$  during decrease of the manipulated variable. The P-, I- and D-part as well as the disturbance variable  $z$  is limited in the rise speed.

This setting speed limit is used:

- to avoid integral saturations in the actuating times of the following actuator  $> 1$  s
- to avoid hard output surges of the P-, D- and z-part.

In this case it must be taken into account that the control time is greater.

- **S2 = 1: two-position controller, with 2 S-outputs heating/cooling; optionally one K-output**

This output structure is identical to the K-output structure in its switching options (see figure 3-22, page96 and figure 3-23, page97).

The controller can be operated exclusively as a two-position controller (both outputs as switching outputs) or as a controller with one K-output and one switching output.

The output variable can only adopt two states for every switching output +  $\Delta y$ , - $\Delta y$ . Switching on or switching off. The relationship between switching on- and switching off is defined as

$$\text{setting ratio} = \frac{\text{switch-on duration}}{\text{switch-on duration} + \text{switch-off duration}}$$

Switch on duration and switch off duration together give the period duration.

The setting range  $y$  from 0 to 100 % can be divided into two sub-ranges. The range Y1 with a falling characteristic for cooling, the range 100% Y2 with rising characteristic for heating. Two pulse stages are connected in series which transform the two sub manipulated variables into pulse-pause ratio. It is possible to use the manipulated variable limiting of  $y$  with the parameters  $yA$  and  $yE$ , the setting ratio 1 is then not reached. Since the minimum pulse duration or -pause can be set by  $tA$  or  $tE$ , further limiting is not normally necessary. A dead zone can bset between these two sub manipulated variables. By changing Y1 or Y2 (oFPA) the dead zone is preset and the slope adapted to the cooling- or heating aggregate.

Factory setting  $Y1 = Y2 = 50\%$  corresponds to dead zone = 0 %.

Every sub manipulated variable can be assigned a different period duration  $tP$  and  $tM$  (onPA). In every chapter the setting ratio 0 to 1 is run through, whereby the shortest switch on- or switch off duration is set with  $tE$  and  $tA$  (onPA). The period duration must be set so that the respective best compromise between the minimum permissible switch on duration of the actuator (e.g. contactor, solenoid valve, fan, cooling compressor), the switching frequency and the resulting curve of the controller variable is found.

With structure switch S56 one of the outputs Y1 and Y2 can be switched to the analog output (as of software version -B2).

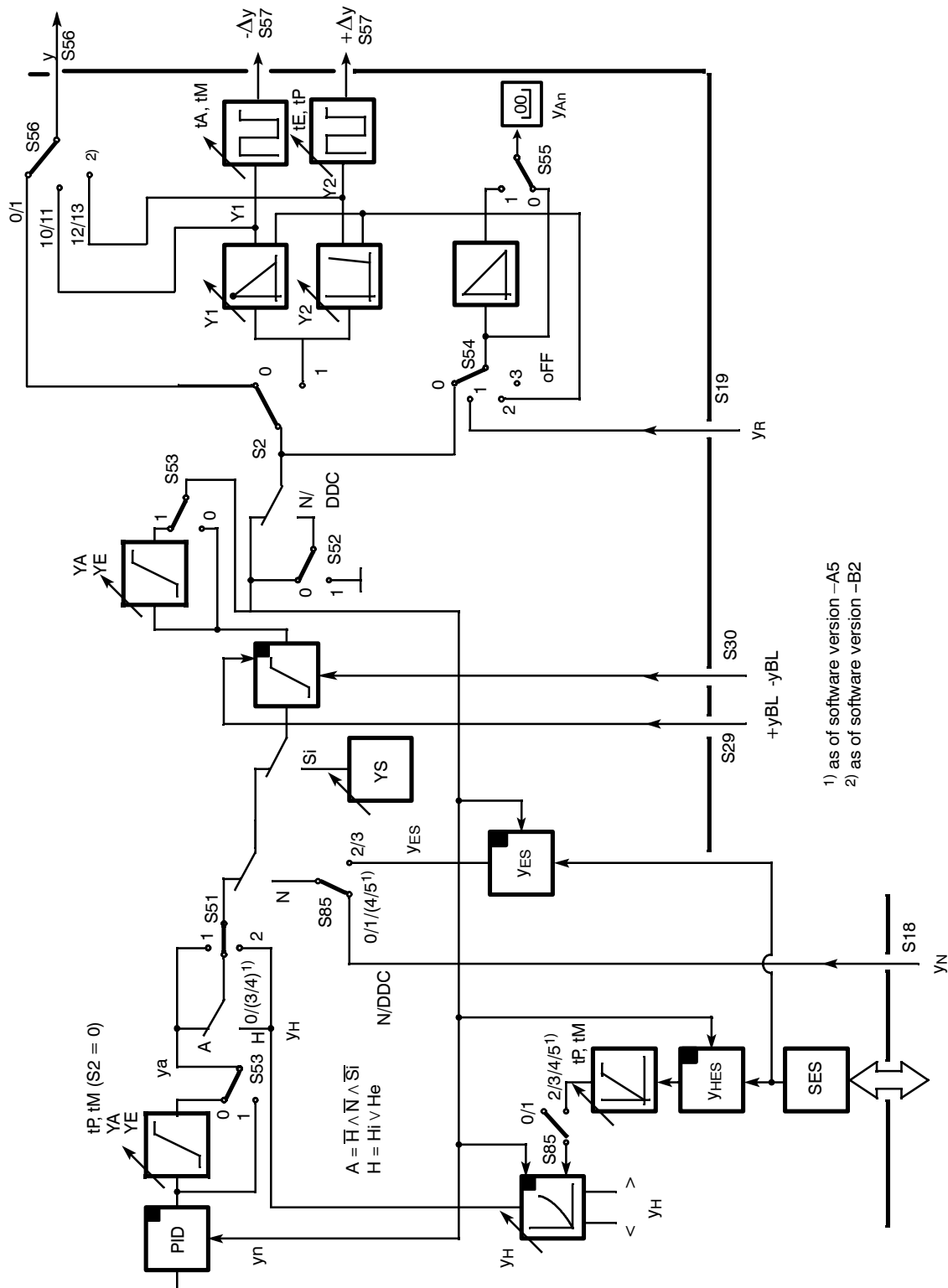

Figure 3-22 Block diagram K-controller S2 = 0 or two-position output S2 = 1  
 Tracking (DDC) has priority over manual operation S49 = 0



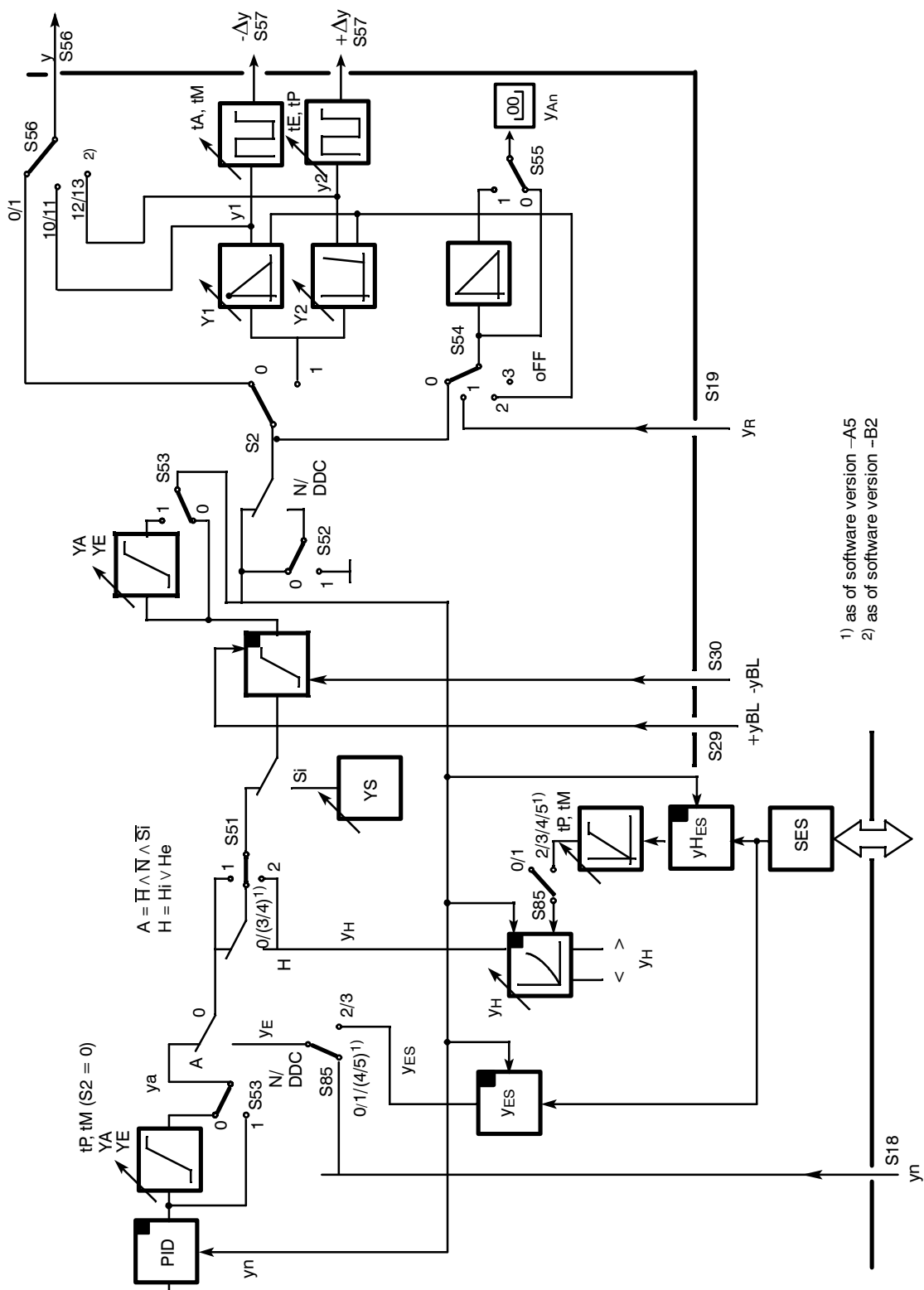

Figure 3-23 Block diagram K-controller S2 = 0 or two-position output S2 = 1  
 Manual operation has priority over tracking operation S49 = 1

**Y-display:**

In switch position S54=2 the setting ranges heating/cooling are displayed with their setting ratio [%]. Switching of the output stages is visible as a point in the display (10) and indicates the setting range heating/cooling.

The  $\pm \Delta y$ -outputs can be assigned to the appropriate digital outputs with the structure switch S57.

The analog output is assigned by the structure switch S56.

$y = 0$  to  $Y1$  (cooling  $-\Delta y$ )  
 period duration  $tM$  from 0 to 1000 s  
 minimum pulse pause, -length:  $tA$

$y = Y2$  to 100% (heating  $+\Delta y$ )  
 period duration  $tP$  from 0 to 1000s  
 minimum pulse pause, -length:  $tE$

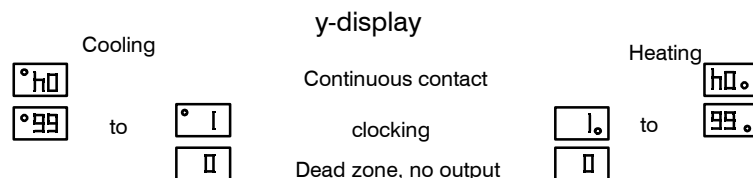
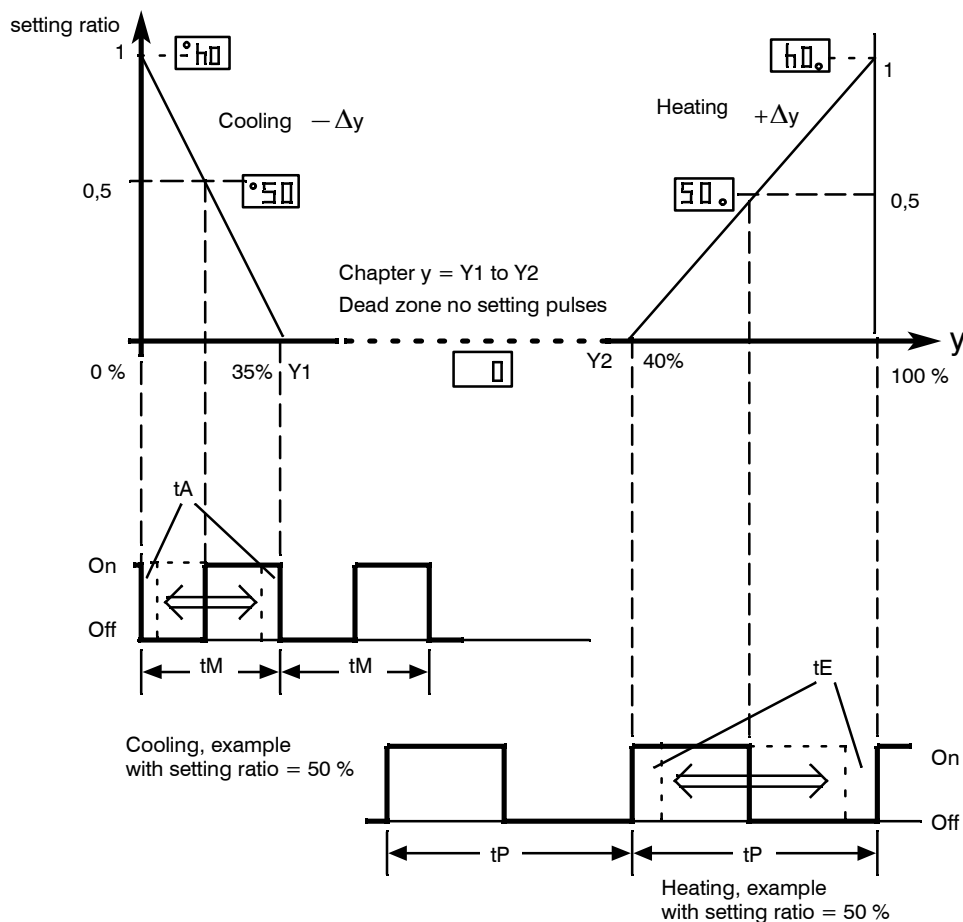

Figure 3-24 Setting ratio, actuating pulses of two-position controller

- **S2 = 2: Three-position step controller (S) with internal feedback**

see figure 3-25, page 100 and figure 3-26, page 101

To control I-acting motorized actuating drives.

In S-controllers with internal feedback the K-controller is followed by an internal position controller. The positioning control circuit consists of a comparator with following three-position switch with hysteresis and an integrator in the feedback. The I-function of the actuator is simulated by the integrator with adjustable actuating time  $t_Y$  (parameterization mode onPA) which replaces the position feedback. To ensure the internal integrator and the K-controller output do not drift apart or into saturation in time, both are set back rhythmically by the same amount (synchronized). The y-output is only a relative manipulated variable. It is therefore not possible to perform a manipulated variable limiting of YA and an absolute value preset of YE und YS. The safety manipulated variable YS is specified as a direction-dependent continuous contact. At  $Y_S \leq 50\%$  (oFPA)  $-\Delta y$  switches, at  $Y_S > 50\%$ ,  $+\Delta y$  switches to continuous contact so that the end positions of the actuator represent the safety position. The position controller has an adjustable minimum pulse length ( $t_E$ ) and-pause ( $t_A$ ) with which the response threshold of the position controller is set indirectly:

- Switching on  $A_{ee} = 2 \cdot \frac{100\% \cdot t_E}{t_Y}$
- Switching off  $A_{ea} = \frac{100\% \cdot t_E}{t_Y}$
- Hysteresis  $A_{ee} - A_{ea} = \frac{100\% \cdot t_E}{t_Y}$
- Pause  $A_a = \frac{100\% \cdot t_A}{t_Y}$
- $t_Y = t_P, t_M$  set actuating time (parameterization mode onPA)

$A_{ee}$  must be set up after a pulse pause at least as a deviation until an actuating pulse with length  $t_E$  is output.  $A_{ea}$  can remain as a constant control error of the position control circuit.

$A_a$  can be set up after an actuating pulse as a deviation until an actuating pulse is output in the same or opposite direction. When time  $t_A$  has expired, the position controller reacts accordingly to the set  $t_E$ .

Setting criteria of  $t_A$  and  $t_E$ , see chapter 6.3, page 183.

The position feedback  $y_R$  is only used to display the manipulated variable in S-controllers with internal feedback. If it is not connected, S54 is set to 3, the y-display (9) is then dark.

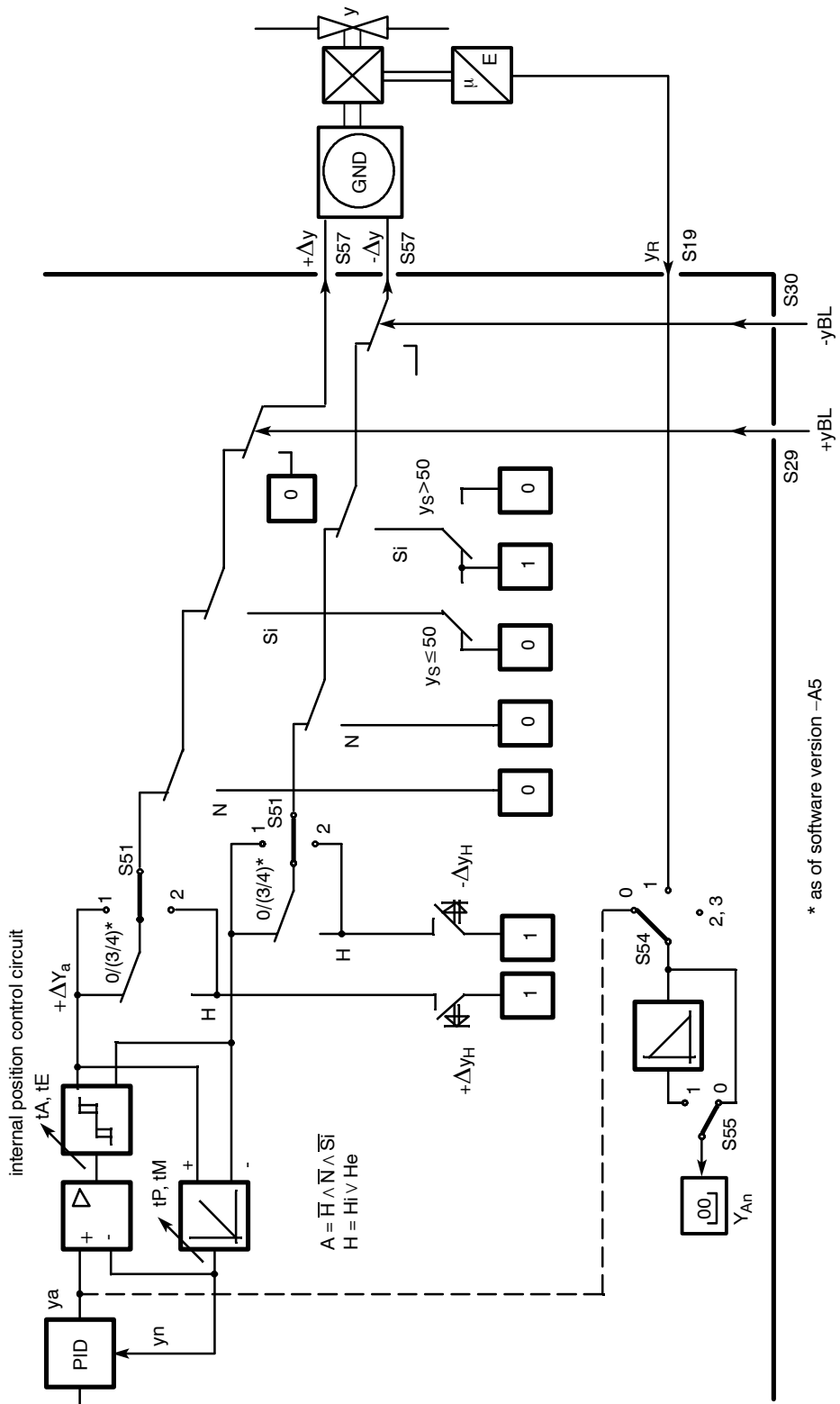

Figure 3-25 Block diagram  
 S-controller with internal feedback S2 = 2  
 Tracking (DDC) has priority over manual operation S49 = 0

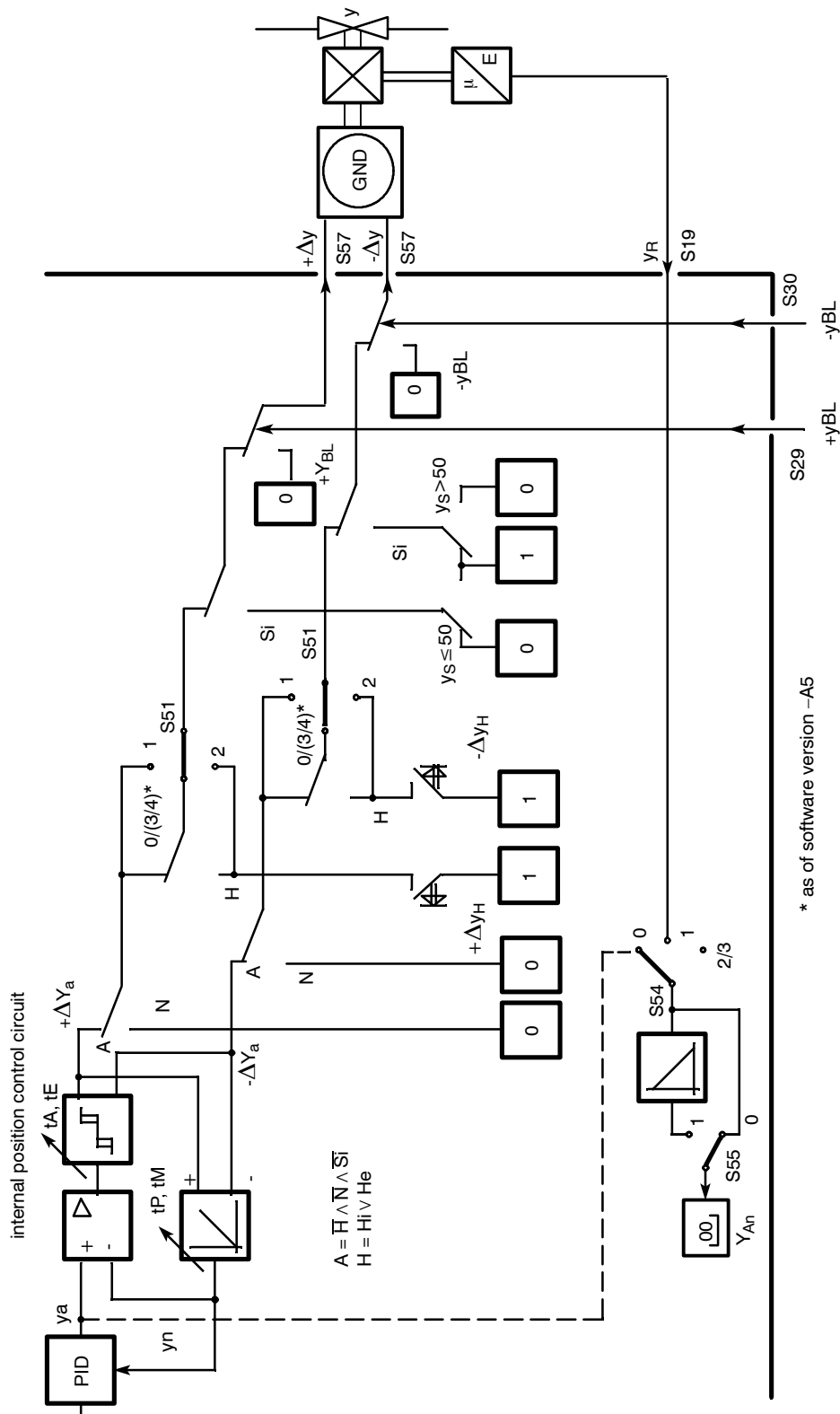

Figure 3-26 Block diagram  
 S-controller with internal feedback S2 = 2  
 Manual operation has priority over tracking (DDC) S49 = 1

● **S2 = 3: Three-position step controller (S) with external feedback**

see figure 3-27, page 104 and figure 3-28, page 105

To control I-acting motorized actuating drives.

In S-controllers with external feedback the "internal position control circuit" is replaced by a real position controller (with the K-controller output  $y$  as a setpoint and the position feedback  $y_R$  as an actual value). As a result a manipulated variable limiting of  $y_a$  and an absolute value preset of  $y_E$  and  $y_S$  are now possible.

With the absolute value preset of  $y_E$  it is also possible to preset the manual manipulated variable via the SES as an absolute value  $y_{ES}$  in tracking operation.

Here too the response threshold of the position controller is preset with the parameters  $t_E$  (minimum turn-on duration) and  $t_A$  (minimum turn-off duration) in connection with  $t_P$  and  $t_M$  (actuating time positive/negative direction) which are all set in the parameterization mode onPA:

- Switching on  $A_{ee} = 4 \frac{100 \% \cdot t_E}{t_Y}$
- Switching off  $A_{ea} = 3 \frac{100 \% \cdot t_E}{t_Y}$
- Hysteresis  $A_{ee} - A_{ea} = \frac{100 \% \cdot t_E}{t_Y}$
- Pause  $A_a = \frac{100 \% \cdot t_A}{t_Y}$

$t_Y = t_P, t_M$  set actuating time (parameterization mode onPA)

If a control deviation of  $x_{ds} \geq A_{ee}$  is set up, the three-position switch switches direction-dependently to continuous contact.  $x_{ds}$  is reduced by the negative follow-up of the position control circuit until  $x_{ds} < A_{ea}$  is reached. The continuous contact is now switched off. After the pause time  $t_A$  pulses of length  $t_E$  are output with subsequent pause time  $t_A$  until  $x_{ds} \leq -A_{ee}$  is reached.

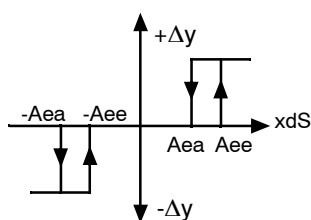

These single pulses are also output if  $x_{ds}$  coming from zero does not reach  $A_{ee}$ . These single pulses which are not fully transformed into the path change (rotational movement) additionally settle the control circuit, i.e. in theory (without lag) the single pulses would switch off at 0.25 or 0.5  $A_{ee}$ . The opposite direction can only occur at appropriate control deviation after the pause time  $t_A$ .

---

The manual adjustment is made as an incremental adjustment by far overranging of the three-position switch so that manual adjustment is also possible when the position feedback is interrupted. (Only at S54=1 or 3)

To simplify commissioning of the position control circuit, the manual manipulated variable is preset absolutely at S54=0 (manipulated variable of the K-controller) so that the setpoint of the position control circuit is changed continuously by the manual manipulated variable in this structure switch position to enable optimization (see chapter 6.2, page 183 ). It should be taken into account here that the manual manipulated variable which is also displayed is changed faster by the actuating time  $t_Y$  than the active manipulated variable on the actuator and a lag therefore takes place. The controlling status can be monitored on the  $\Delta y$ -LEDs (9) in the y-display. After optimization, S54 should be set to 1 to display the active manipulated variable via the position feedback  $y_R$ .

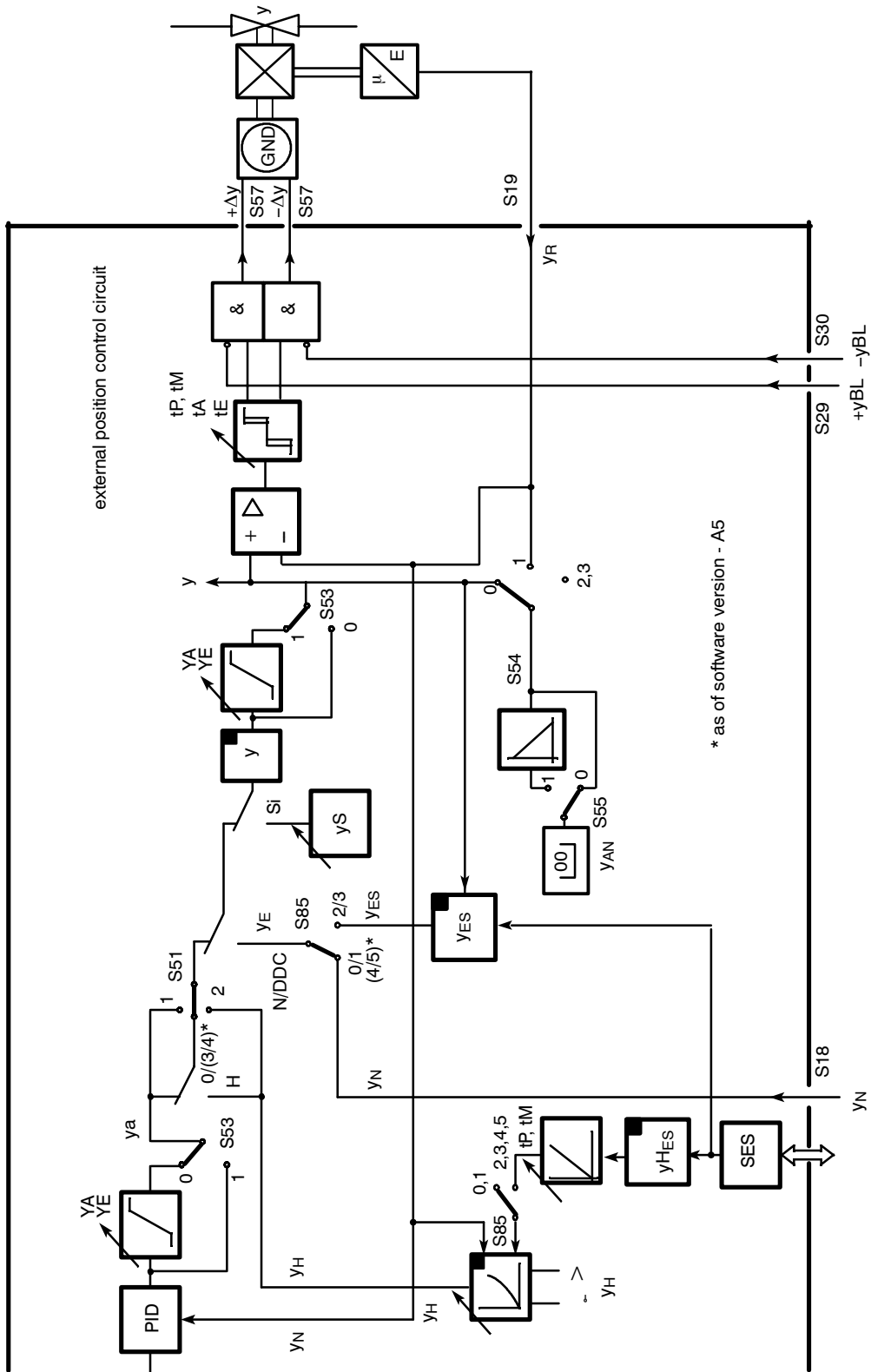

Figure 3-27 Block diagram S-controller with external feedback  $S2 = 3$   
 Tracking (DDC) has priority over manual operation  $S49 = 0$



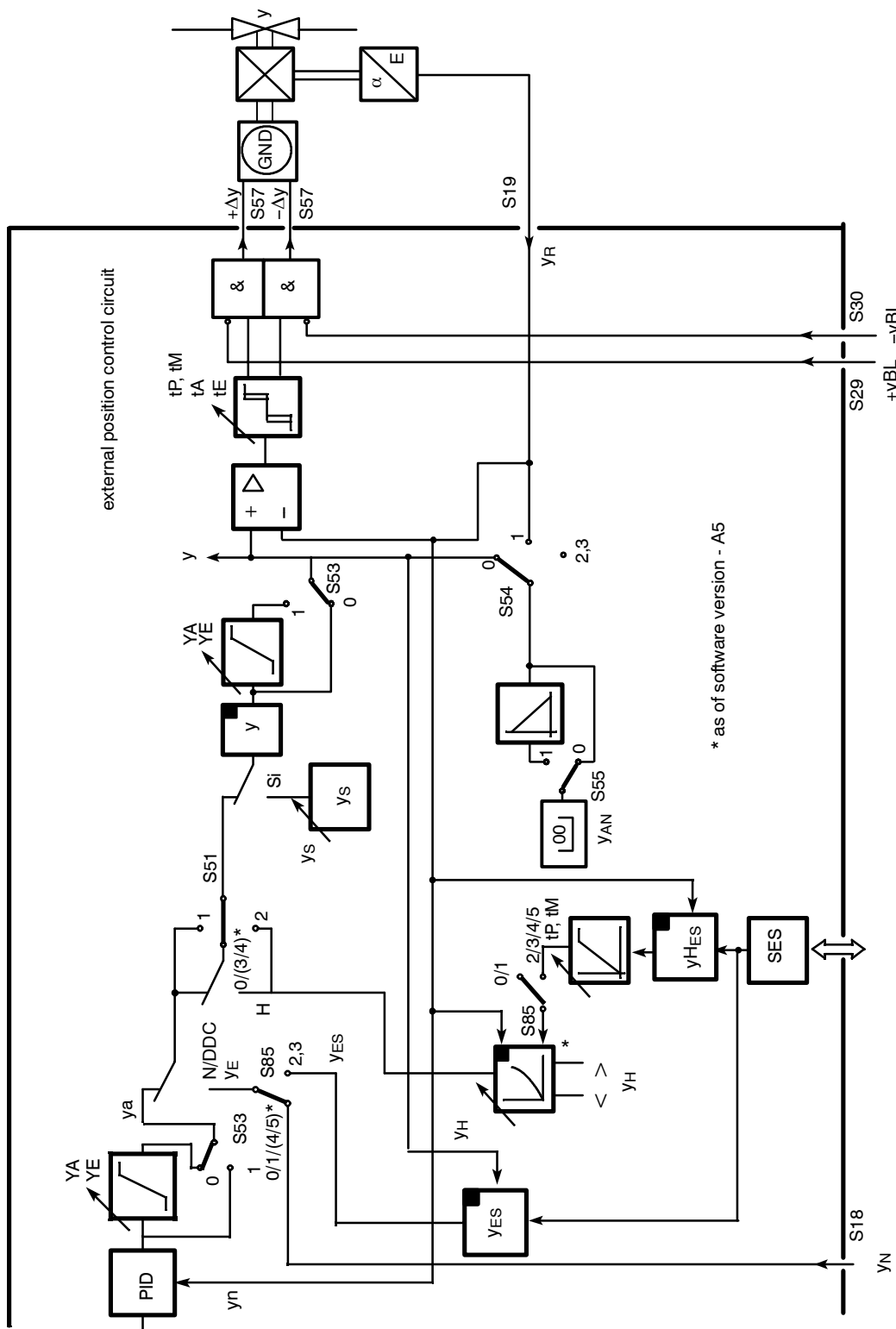

Figure 3-28 Block diagram S-controller with external feedback S2 =3  
 Manual operation has priority over tracking (DDC) S49 = 1

Control signals					Message signals				active y	Explanation
Digital inputs			Front		Front		Digital outputs			
$\pm y_{BL}$	Si	N	He <sup>7)</sup>	Hi <sup>8)</sup>	H LED	y-Ext. LED	H	Nw		
0	0	0	0	0	0	0	0	0	$y_a(n)$	Automatic mode
0	0	0	1	0	0,9 <sup>4)</sup>	0	1	0	$y_H(n), (\nearrow)$	Manual mode
0	0	0	0	1	1	0	1	0	$y_H(n), (\nearrow)$	Manual mode
0	0	0	1	1	1	0	1	0	$y_H(n), (\nearrow)$	Manual mode
0	0	1	0	0	0	1	0	1	$y_E(n)^{1)}$	Tracking operation
0	0	1	1	0	0,5 <sup>5)</sup>	1	1	1	$y_E(n)$	Tracking operation
0	0	1	0	1	0,5 <sup>5)</sup>	1	1	1	$y_E(n)$	Tracking operation
0	0	1	1	1	0,5 <sup>5)</sup>	1	1	1	$y_E(n)$	Tracking operation
1	0	as above			0,5 <sup>5)6)</sup>	1	as above	0	$\pm y_{BL}^{2)}$	$\pm$ Blocking mode
1	1	as above			0,5 <sup>5)6)</sup>	1		0	$\pm y_{BL}^{2)}$	$\pm$ Blocking mode
0	1	as above			0,5 <sup>5)6)</sup>	1		0	$y_S^{3)}$	Safety operation

Table 3-15 Output switching of all controller types except DDC-fixed setpoint controller (S1 = 2)  
 Tracking operation has priority over manual operation (S49 = 0)

Control signals					Message signals				active y	Explanation
Digital inputs			Front		Front		Digital outputs			
$\pm y_{BL}$	Si	N	He <sup>7)</sup>	Hi <sup>8)</sup>	H LED	y-Ext. LED	H	Nw		
0	0	0	0	0	0	0	0	0	$y_a(n)$	Automatic mode
0	0	0	1	0	0,9 <sup>4)</sup>	0	1	0	$y_H(n), (\nearrow)$	Manual mode
0	0	0	0	1	1	0	1	0	$y_H(n), (\nearrow)$	Manual mode
0	0	0	1	1	1	0	1	0	$y_H(n), (\nearrow)$	Manual mode
0	0	1	0	0	0	1	0	1	$y_E(n)^{1)}$	Tracking operation
0	0	1	1	0	0,9 <sup>4)</sup>	0,5 <sup>5)</sup>	1	0	$y_H(n), (\nearrow)$	Manual mode
0	0	1	0	1	1	0,5 <sup>5)</sup>	1	0	$y_H(n), (\nearrow)$	Manual mode
0	0	1	1	1	1	0,5 <sup>5)</sup>	1	0	$y_H(n), (\nearrow)$	Manual mode
1	0	as above			0,5 <sup>5)6)</sup>	1	as above	0	$\pm y_{BL}^{2)}$	$\pm$ Blocking mode
1	1	as above			0,5 <sup>5)6)</sup>	1		0	$\pm y_{BL}^{2)}$	$\pm$ Blocking mode
0	1	as above			0,5 <sup>5)6)</sup>	1		0	$y_S^{3)}$	Safety operation

Table 3-16 Output switching of all controller types except DDC-fixed setpoint controller (S1 = 2)  
 Manual operation has priority over tracking operation (S49 = 1)

- 1) Source for  $y_E$  is at S85=0,1 (4, 5 as of software version -A5)  $y_N$ , at S85=2, 3  $y_{ES}$  via the SES. The external manipulated variable fed in through the SES ( $y_{ES}$ ) is tracked. When feeding in via  $y_N$  the feeding instrument must be tracked.
- 2) Blocking operation acts direction-dependently, changes to the opposite direction are possible.
- 3) Function  $y_S$  in S-controllers with internal feedback (S2 = 1) drive open- or closed otherwise parameterizable safety setting value.
- 4) 0.9 flashing rhythm 0.1 off, 0.9 on
- 5) 0.5 flashing rhythm 1:1
- n Tracked to the value active before switching, therefore bumpless switching
- $\nearrow$  adjustable
- 6) only if  $Hi \vee He$
- 7) for S51  $\neq$  3, 4
- 8) As of software version -A7 the signals  $He_{DI}$  and  $He_{ES}$  with S52 = 3, 4 have dynamic effect (0/1-edge). They then act like the Hi-signal (see figure 3-3, page 53)

- **Automatic mode ( $y = y_a$ )**

The automatic mode is switched on with the Automatic/Manual key or in the case of dynamic switching (S51= 3,4) <sup>1)</sup> via He (yellow manual LED (8) off). All other control signals He, N (DDC), Si and  $\pm yBL$  must be 0. The automatic manipulated variable is connected through to the controller output.

- **Manual mode ( $y = y_H$ )**

Manual operation is switched on by the Automatic/Manual key (yellow manual LED(12) on) or the control signal He as an OR function. The control signal He acts statically in the structure switch positions S51 = 0,1 static. At S51 = 3,4 it is dynamic, i.e. every positive edge causes a switching process. The control signals Si and  $\pm yBL$  must be 0. If tracking operation has priority over manual operation (S49=0), the control signal N (DDC) must also be 0. Otherwise tracking operation or safety- or blocking operation become active, the manual-LED then flashes in 0.5 rhythm as an identification. The manual manipulated variable is switched through to the controller output. The manual manipulated variable is preset in K-controllers as an absolute value, in S-controllers as a positioning increment.

- **Tracking-(DDC)-operation ( $y = y_E$ )**

The tracking operation is switched on by the control signal N (in DDC-mode by the control signal CB and the Internal/External, see chapter 3.4.4, page 68). The control signals Si and  $\pm yBL$  must be 0. If manual mode has priority over tracking mode (S49 = 1) the control signal  $H = H_i \vee H_e$  must be 0.

The external manipulated variable  $y_E$  is connected through to the controller output. The source for  $y_E$  at S85 = 0, 1, (4, 5 as of software version -A05), is preset as an absolute value  $y_N$ . With S85 = 2, 3 the absolute value becomes active as an external manipulated variable via the SES ( $y_{ES}$ ).

In S-controllers with internal feedback (S2 = 2), absolute value presets of the manipulated variable and thus the tracking operation are not possible.

- **Safety operation ( $y = YS$ )**

The safety operation is switched on by the control signal Si. The control signal  $\pm yBL$  must be 0. The safety manipulated variable YS is through connected which can be set as a parameter in the structuring mode oFPA in the range from -10 to 110 %. In S-controllers with internal feedback (S2 = 2) absolute value preset of the manipulated variable is not possible. When safety operation is active, at  $YS \leq 50\%$   $-\Delta y$  continuous contact and at  $YS > 50\%$   $+\Delta y$  continuous contact is output so that the actuator drives to the end positions.

<sup>1)</sup> as of software version - A05

- **Direction-dependent blocking operation**

Blocking operation is controlled by the control signals  $\pm yBL$ . All other control signals have no function. If a control signal is applied the manipulated variable output is blocked direction-dependently, i.e. only changes in the opposite direction are allowed. If both control signals are applied simultaneously, the output is blocked absolutely. The direction-dependent blocking is necessary especially in S-controllers with internal feedback and actuators with limit stop switches to avoid integral saturation. If the control circuit is opened on reaching the end position of the actuator, further integration of the controller must be prevented in order to be able to react immediately in the event of control difference reversal.

As described above, the control signals  $\pm yBL$  have priority over Si and H or N. Priority of H or N can be selected via S49. All these operating modes have priority over automatic operation.

Signaling of the switching states is made by the LEDs Manual (12) and y-external (13). When manual mode is active or preselected (if the priority operating modes are active), the manual LED lights up.  $He = 1$  is signaled by a flashing rhythm of 0.9 (control signal) if  $Hi = 0$  (i.e. is in automatic mode by the manual/automatic switching). When switching the control signal  $He$  from 1  $\rightarrow$  0 the automatic mode becomes active.

Tracking-(DDC), safety-and blocking operation is signaled by the y-External LED. Flashing rhythm 0.5 indicates that in "manual operation priority over tracking operation", manual operation is active but tracking operation is prepared and after switching to automatic operation also becomes active.

- **Blocking of the manual/automatic switching (S51)**

With S51 the manual/automatic switching can be blocked in the operating mode Automatic mode only or Manual mode only. The other operating modes are still possible. Then, tracking mode is only possible if tracking has priority over manual mode (see figure 3-22, page 96).

- **Manual mode in the case of a transmitter fault (S50)**

With S50 manual mode can be switched to when the transmitter group fault message occurs (see chapter 3.2, page 47). Manual operation starts at  $S50=1$  with the last y or at  $S50 = 2$  with the parameterized YS. In both cases the manual manipulated variable can be adjusted with the  $\pm \Delta y$  keys after switching.

- **Source and direction of effect of the y-display (S54, S55)**

With S54 the y-display is switched to the different display sources or switched off. The absolute manipulated variable y or the split range-manipulated variables  $y_1$  and  $y_2$  in two-position controllers heating/cooling or the position feedback-signal  $y_R$  in three-position-S-controllers can be displayed.

With S55 the display direction rising/falling can be selected (see chapter 6.1), page 181.

- **Control system coupling via the serial interface**

As of software version A5 in addition to the DDC controller (S1 = 2) the SPC controller (S1 = 1) a parallel process operation is possible in all controller types via the serial interface. The control signals  $Int$  and  $Hi$  (via  $He_{ES}$  at S51 = 3/4, see chapter 3.3, page 50) and the process variables  $w_i$  and  $y_H$  can be written at S85  $\geq$  2 via the serial interface so that switching from internal to external setpoint and Automatic/Manual switching is possible in all controller types. If the internal setpoint  $w_i$  or the manual manipulated variable  $y_H$  is active it can also be changed by the SES or the adjusting keys on the front panel. Since the SES can only adjust absolutely and not incrementally, it is advisable to use the setpoint ramp (tS) or the dynamic manipulated variable with tP and tM to avoid steps.

This parallel operation using the serial interface can be locked at S51 = 3 by  $\overline{RC} = Int \vee \overline{CB}$  (see figure 3-3, page 53). This locking facility for the operation via SES on the controller front is only useful in the controller types fixed setpoint controller with a setpoint (S1 = 5) and follow-up controller without Internal/External switching (S1 = 6) because in all other controller types both the Internal key and the control signal CB have other additional functions.

At S51 = 4 this locking facility is omitted and operation is always parallel to the front keys.

To avoid simultaneous actuation by the controller front and the SES the last switching action can be read on the process control system. For this, a status bit is set when writing  $Int_{ES}$  and  $He_{ES}$  which is only reset when the front keys  $Int$  or  $Hi$  are actuated. By requesting the status bit, the process control system can issue a warning when the last operation took place via the front.

If the last operation took place via the SES the warning SES flashes for 3 s in the x/w display when the Internal key or the Manual key is pressed. This initial pressing of the keys does not activate a switching function, only when the keys are pressed again is the desired switching function triggered.

At S84 = 1 writing of status signals  $Si_{ES}...$  to  $...tSH_{ES}$  is locked by  $/RC$ .

If the last operation took place via the serial interface the warning SES flashes for 3 s in the x/w display when the internal key or the manual key is pressed. This initial pressing of the keys does not activate a switching function, only when the keys are pressed again is the desired switching function triggered.

At S84 = 2 writing of status signals  $Si_{ES}...$  to  $...tSH_{ES}$  is locked by CB.

At S84 = 3\*) the status signals  $Si_{ES}...$  to  $...tSH_{ES}$  are always available via the serial interface (siehe figure 3-3, page 53).

\*) as of software version C1

### 3.7 Analog output signal processing (S56)

The controller-internal variables are assigned to the analog output AO/ly by structure switch S56, whereby every controller variable can be structured to 0 or 4 to 20 mA.

The bipolar process variable xd is output with an offset of 50 % (10 mA or 12 mA).

#### Analog output ly assignment and current range

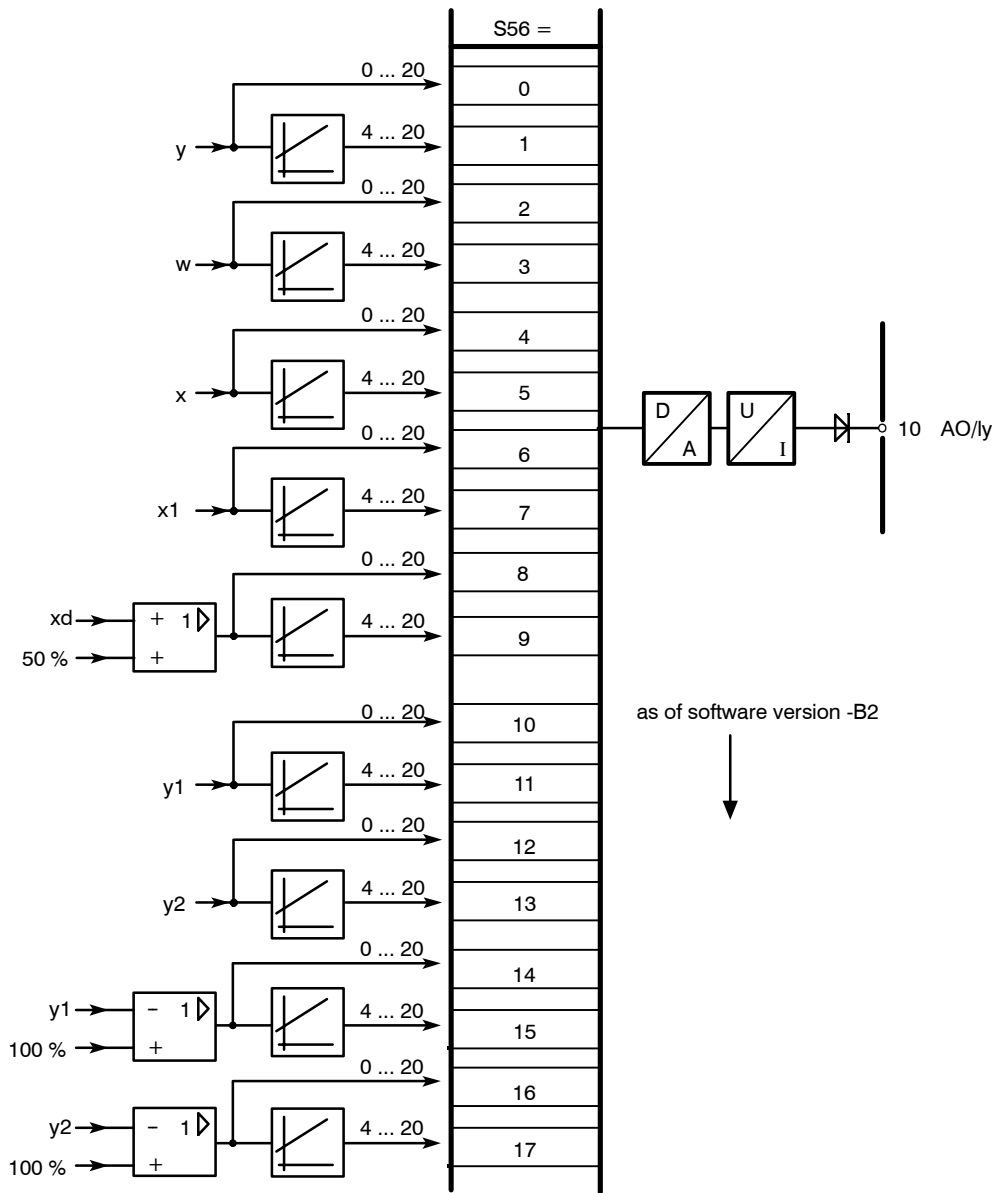

Figure 3-29

### 3.8 Digital output signal processing (S57 to S75)

The message signals  $\overline{RB}$ ,  $\overline{RC}$  ... MUF,  $+\Delta w$  and  $-\Delta w$  are assigned to the digital outputs DO1 to DO8 by the structure switches S58 to S68 and can be negated optionally with the structure switches S69 to S75 (except  $+\Delta w$  and  $-\Delta w$ ) (see figure 3-30, page 112).

The digital outputs DO1, DO2 and DO7, DO8 of the standard controller can be extended with the options modules 4DO 24 V +2DI (6DR2801-8E) or 2DO-relay 35 V (6DR2801-8A) in slot 3 to a maximum 6 or 8 digital outputs respectively. When using 4DO 24 V +2DI in slot 3 by DO3 to DO6, when using 2DO-relay 35 V in slot 3 by DO3 and DO4.

When using options modules in slot 3, structure switch S22 must be set according to the assignment, otherwise there will be error messages (see chapter 5.5, page 179).

The control signals  $\pm \Delta y$  (positioning increments of the S-controllers) are not negatable but they can be assigned to one of the binary outputs DO1, DO2, DO7 or DO8. The setting of S57 has priority over assignments with S58 to S68. The assigned digital outputs for  $\pm \Delta y$  are not stored in "ST5" and "BABE" (refresh-time approx. 20 ms). Description of ST5 and BABE: see operating instructions "Serial SIPART 6DR190x Bus Interface".

On assigning different control signals to the same digital output an OR-function of the control signals is produced (exception at  $\pm \Delta y$ ).

Unassigned digital outputs (switch position 0) are low and can be set by SES at S85 = 2. All digital outputs have wired-or-diodes.

#### ● Functional explanation of the digital message signals.

$\overline{RB}$	<i>No computer standby of the controller</i> This signal indicates that the controller is in internal operation, i.e. not in computer standby.
$\overline{RC}$	<i>Computer operation</i> This signal indicates the negated computer operation $\overline{RC} = \overline{Int} \wedge \overline{CB}$ and controls the setpoint switching or DDC-operation.
H	<i>Manual mode</i> The controller is in manual mode, triggered either by manual/automatic-switching on the front of the controller (Hi) or by the digital input signal He if the control signals Si, $\pm yBL$ and N (with tracking over manual operation priority) are Low.
Nw	<i>Tracking operation</i> The controller is in tracking mode when the control signals Si, $\pm yBL$ and H (in manual over tracking operation priority) are Low and the control signal N is High.
A1/A2	<i>Alarm 1 and 2</i> indicate response of the limit value alarms A1 and A2.
A3/A4	<i>Alarm 3 and 4</i> indicates response of the limit value alarms A3 and A4.
MUF	<i>Transmitter fault</i> The instruments's analog input signals can be monitored for exceeding of the measuring range. This signal gives a group alarm if an error is detected.
$\pm \Delta y$	<i>positioning increments for the <math>\Delta y</math>-adjustment in S-controllers</i>
$\pm \Delta w$	<i>positioning increments for the <math>\Delta w</math>-adjustment, only for control unit/process display (S1 = 4)</i>

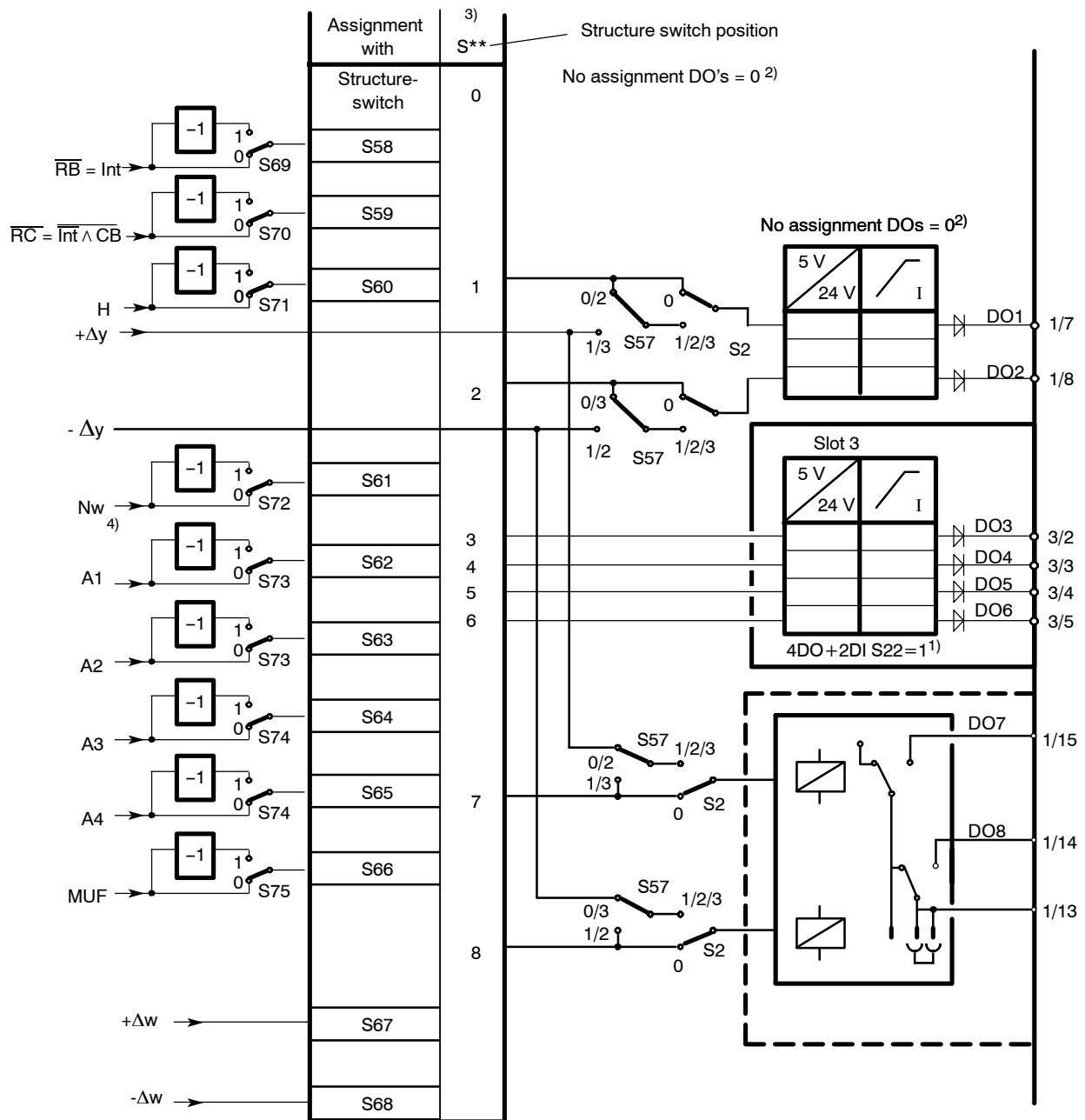

- 1) When using 2DO-relay 35 V, 6DR2801-8A (S22 = 3), only DO3 and DO4 are available.
- 2) At S\*\*=0 there is no assignment, the digital outputs are then 0 and can be set at S85 = 2 by the SES.
- 3) Assignment of different control signals to one digital output causes an OR-function.
- 4) Message signal active tracking mode see page 111.

Figure 3-30 Assignment of digital outputs (S57 to S75)



## 3.9 Adaptation (S48)

The adaptation procedure represents a reliable and easy to operate commissioning tool. The adaptation procedure is far superior to manual optimization especially in slow controlled systems and in PID controller types. It is activated by the operator and can be aborted at any time in the event of danger. The parameters determined by the adaptation can be changed and accepted specifically by the user.

In the parameterization mode AdAP which is only accessible at  $S48 \neq 0$ , the following presettings are made for the adaptation procedure:

tU Monitoring time  
Pv Direction of step command  
dY Amplitude of step command

With the structure switch S48 the choice of the control behavior (with or without overshoot) is made.

The adaptation principle is divided into system identification and controller design.

### ● System identification

The controller is driven to the desired operating point manually. By pressing the Enter key the set manual manipulated variable is changed by a step adjustable in the direction (dPv) and amplitude (dY). The y-step is output at the end of 10 % of the set monitoring time (tU) if there was a fixed state of the controlled variable during this time. Otherwise there is an error message with abortion of the identification (see table 5-3, page 162 ).

The step response of the controlled system is then accepted with a max. 84 value pairs (time and amplitude). The respective main controlled variable of the different control types is filtered adaptively – (see figures 3-6, page 61 to figure 3-7, page 62) and provided for saving. The storage procedure operates with cyclic data reduction and subsequent refilling so that slow controlled systems can be entered.

After the start ID has been run through (the controlled variable x must have left the start ID band within 50% of the set monitoring time tU), 95% of the full range must have been reached at the latest at  $\frac{2}{3}$  of tU. The set monitoring time (tU) must be  $\geq 2 * T95$  of the controlled system with safety reserve. The remaining time is required for the full scale identification. The end value identification can also take place immediately after the start identification, but  $\frac{1}{3}$  of the performed measurements are always required for the end value identification. Recording of the measured value pairs is ended on identifying the full scale.

A comparison with the recorded transient function is now made based on the stored Ptn-models with  $n = 1$  to 8 and equal time constants T by variation of n and T. The determined line gain ks is transferred to the line models. The comparison is made over the minimum error area F (n, T)

Additionally a special entry of real dead times is made which then shifts the identified control line to higher orders.

Controlled systems with compensation and periodic transients of 1st and 8th order with a transient time  $T_{95}$  of 5 s to 12 h can be identified. Dead time parts are permissible. In S-controllers, the transient time  $T_{95}$  should be double the actuating time max. ( $tP/tM$ ).

**The monitoring time  $tU$  serves to optimize the cancel criteria.  
 It can always be started with  $tU = \text{off}$  (dynamic system knowledge is unnecessary).**

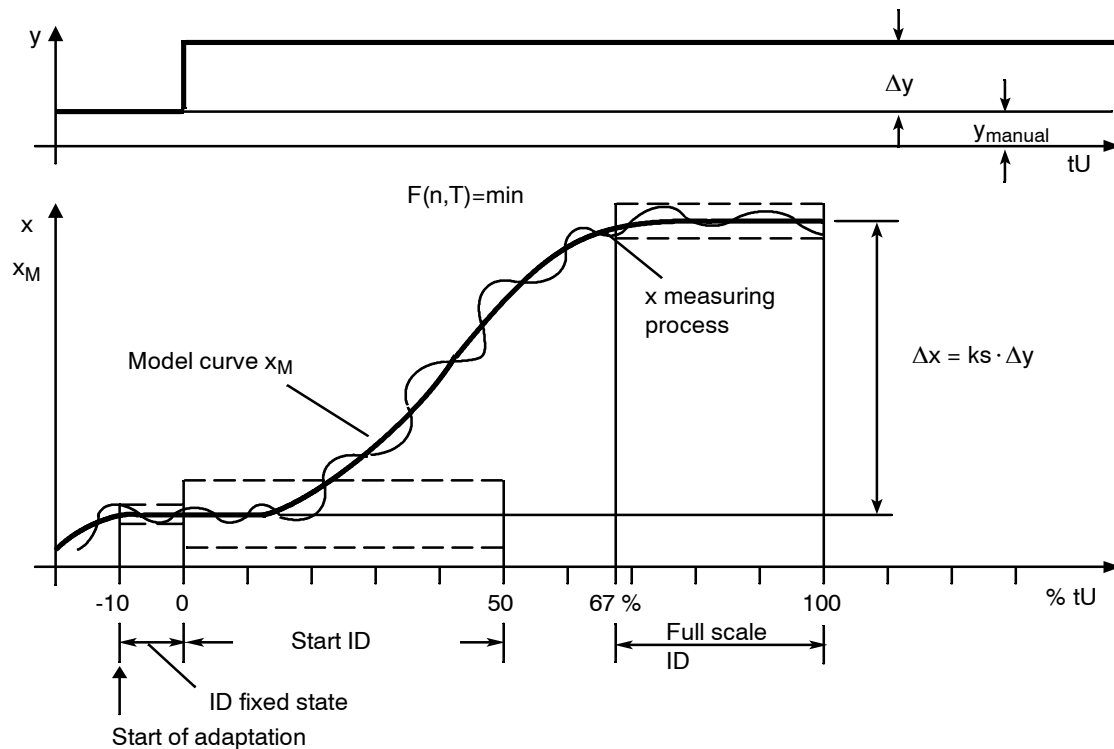

Figure 3-31 Time curve of an adaptation without error messages in which  $tU = 2 \times T_{95}$

Error checks are made during system identification in order to be able to prematurely abort the identification. There are 12 control steps altogether which are displayed by flashing on the digital x- and w-displays when errors occur. As soon as an error message appears, the system identification is aborted and it must be restarted after correcting the presettings in the parameterization mode AdAP if necessary. Acknowledgement of error messages, see chapter 5.4.2, page 155 list of error messages, see table 5-3page 162.

● **Controller design**

The controller is designed according to the amount optimum method (S48=2). This setting method is very robust and also allows variation of the line amplification. However, it generates an overshoot of approx. 5 % in the event of changes in the command variables. If this is undesirable, operation can also take place with the controller design without overshoot (S48 = 1).  $K_p$  is reduced to 80% here.

The controller is designed for PI and PID-behavior, therefore  $K_p$ ,  $t_n$  and for PID  $t_v$  are calculated, whereby the derivative gain is fixed at 5. A prerequisite is that the D-element is connected with  $x_d/x/x_1$  ( $S47 = 0$  or  $2$ ).

In S-controllers the response threshold  $AH$  is calculated in addition to  $K_p$ ,  $t_n$ ,  $t_v$ . The parameters  $t_A$  and  $t_E$  and  $t_P/t_M$  must be set beforehand according to the actuating drives used (see chapter 6.3 page 183). If the transient time  $T_{95}$  is in the vicinity of  $2 t_P/t_M$  (actuating time), overshoots may also occur in controller designs with D-part even at  $S48=1$ .

In 1st order controlled systems a PI or PID controller design, in 2nd order systems a PID controller design cannot be implemented according to the amount optimum because in these cases  $K_p$  goes to  $\infty$ . A controller design is made in which the ratio of system time constant to control circuit constant is 3 ( $S48 = 1$ ) or 10 ( $S48 = 2$ ).

The new parameters for PI-controllers and for PID-controllers are offered when adaptation has been completed.

In addition the determined system order 1 to 8 is displayed as a suffix to the PI- or PID-identification.

The operating technique of the adaptation procedure is described in chapter 5.4.2, page 155, the commissioning explained in chapter 6.5, page 186.

## 3.10 Other functions of the standard controller

### 3.10.1 Adaptive filter

The control difference  $x_d$  is fed through an adaptive filter. By adjusting  $t_F$  (onPA) from oFF to 1 s the filter is switched on. By further increases to  $t_F^*$  the filter can be adapted to a low-frequency disturbance frequency (seconds- to hours time-constant). Within a band in which changes occur repeatedly, changes are interpreted as a fault by the filter and filtered with the preset time constant  $t_F$ , changes in a direction out of the band are passed unfiltered to the PI(D)-algorithm to enable a faster control. If the disturbance level changes in time, the filter is automatically adapted to the new level.

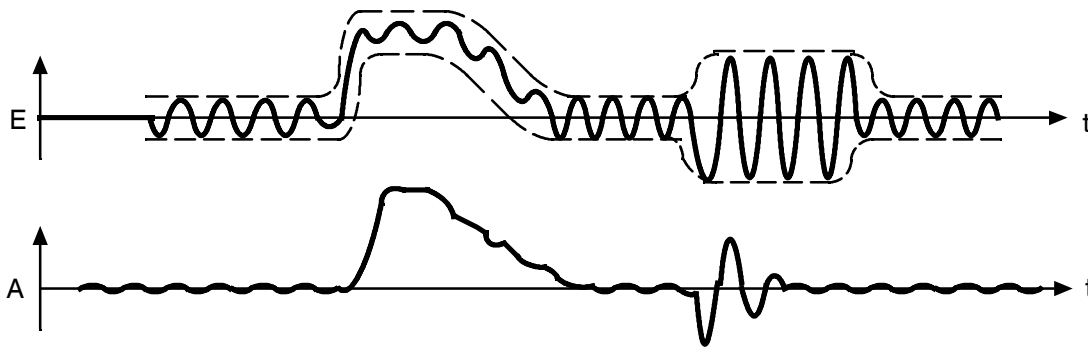

Figure 3-32 Effect of the adaptive non-linear filter

The factory setting of  $t_F$  is 1 s. In controllers with D-part – it should be set as great as possible because of the input noise amplified by  $v_v \cdot k_p$  and in the adaptation.

### 3.10.2 Response threshold AH

The response threshold AH (dead zone element) is in the control difference connected after the adaptive filter.

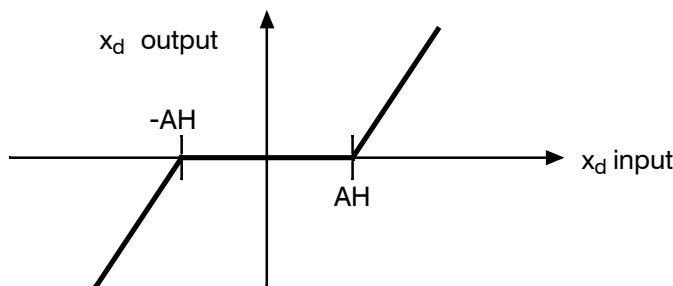

Figure 3-33 Effect of the dead zone element

The dead zone element lends the controller a progressive behavior, at small control differences the gain is low or even 0, at larger control differences the specified  $K_p$  is reached. It should be taken into account that the remaining control difference can adopt the value of the set response threshold AH.

The factory setting of AH is 0 % and can be set up to 10 % in the parameterization mode onPA.

In S-controllers the minimum necessary setting of AH is given by the minimum  $\Delta x = k_s \cdot \Delta y$  (see chapter 6.3, page 183) and can be increased for further settling of the controlled system. In K-controllers a small threshold value is advisable for settling the control circuit and reducing wear on the actuator.

### 3.10.3 Limit value alarm (S76 to S80)

The limit value alarm pairs A1, A2 and A3, A4 are assigned to the controller-internal variables xd, x ... AI3A, AI4A, lxdl by the structure switches S76 and S77. Every limit value alarm pair can be set to the monitoring functions Max/Min, Min/Min or Max/Max by S78 (A1, A2) or S79 (A3, A4).

The response thresholds A1 to A4 and the hysteresis HA are set in the structuring mode oFPA.

According to the switch position of S80 only the display or the display and adjustment of A1 to A4 is possible in the process operation level. In this case the switching cycle of the Shift key (6) is extended by the response thresholds A1, A2 or A1 to A4:

Example display order switching key (6): w - y - A1 - A2 - A3 - A4 - x . . .

The respective limit value is displayed on the y-display (9), the value on the x/w-digital display (3) or the w-bar display (2) and set depending on the assignment physically according to the display format of the digital x/w-display or in %.

S1	S76, S77	assigned to	Display format		Parameter range  x/w-display
			digital x/w-dis- play S80 > 0	Bar display S80 = 5, 6	
0	0	xd	according to dA to dE -1999 to 9999	%	-110 % to 110 % referenced to dE - dA = 100 %
1	↓	↓			
2	5/17	wv/lxdl			
4	6	y	%	%	- 110 % to 110 %
5	↓	↓			
6	16	AI4A			
3	0	xd	%	%	- 110,0 % to 110,0 %
	↓	↓			
	3/17	w/lxdl	according to**) Ad to Ed -1999 to 9999		-110 % to +110 %**) referenced to Ad-Ed=100%
	1/2/3*)	x1/x/w	according to Ad to Ed -1999 to 9999	%	-110 % to +110 % referenced to Ad-Ed=100%
	4	xv	according to dA to dE -1999 to 9999	%	-110 % to 110 % referenced to dE-dA = 100 %
↓	↓				
5	wv				
6	y	y ↓ AI4A	%	%	- 110 % to 110 %
↓	↓				
16					

Table 3-17 Display format of the limit values A1 to A4

\*) as of software version -A9

\*\*) as of software version -C1

A2 cannot be set greater than A1 and A4 not greater than A3.

The hysteresis HA is set in % in the range from 0.1 to 10 % and applies for all 4 limit values.

The function of the limit values (Min oder Max) always relates to the display, i.e. in the case of a falling characteristic ( $dE < dA$ ) the direction of effect is reversed. The set Min-function for example becomes a Max-function related to the field signal.

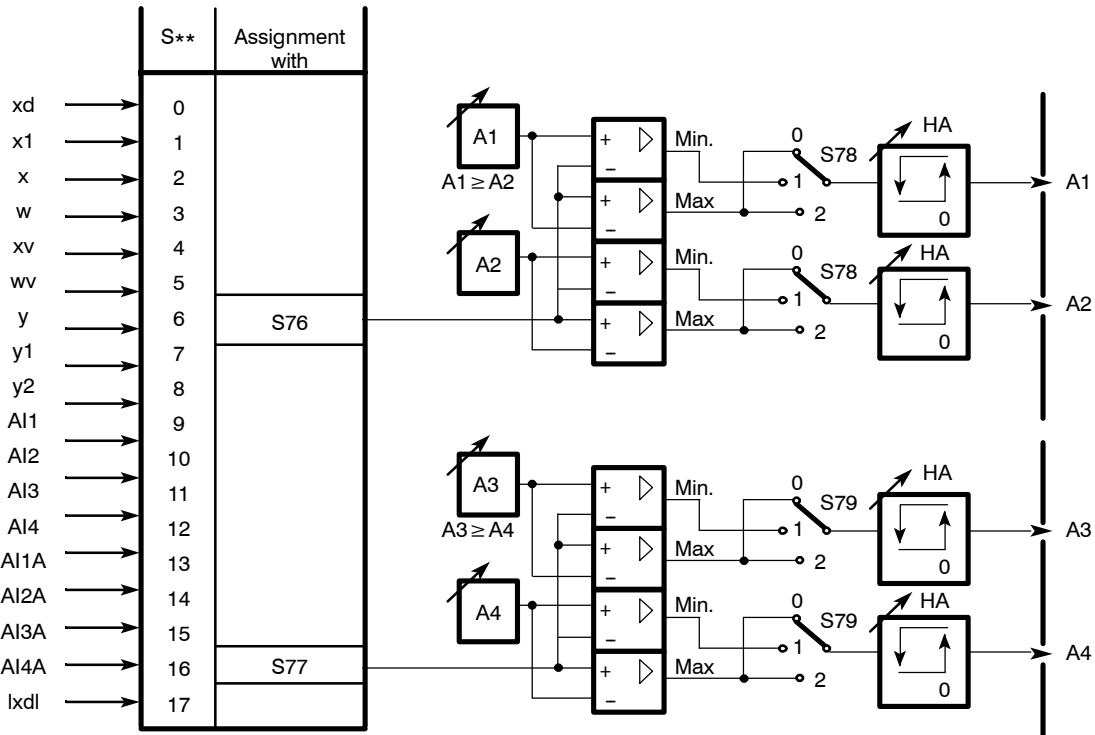

Figure 3-34 Assignment and function of the limit value alarms (S76 to S79)

### 3.10.4 Linearizer (S21, oFPA)

The linearizer is freely assignable to an input AI1 to AI4 or the main controlled variable x1. If the main controlled variable is linearized, the range dA to dE is decisive, otherwise there is a percentage reference to the measuring range. The curve is rounded at the support points.

Example: Thermocouple 300 to 1000 C with transmitter without linearizer

Set start of scale and full scale dA and dE and the decimal point dP in the structuring mode oFPA for the display. Divide measuring range UA to UE including  $\pm 10\%$  overflow in 10 % sections and determine partial voltages.  $L_{-1}$  to  $L_{11}$  are equidistant support points with 10 %-steps.

$$\begin{aligned}
 UA &= 4.31 \text{ mV} \\
 UE &= 48.33 \text{ mV} \\
 U_n &= \frac{UE - UA}{10} \quad n + UA \quad \text{with } n = -1 \text{ to } 11
 \end{aligned}$$

Determine the respective physical value from the appropriate function tables for every  $U_n$  or graphically from the corresponding curve (interpolate if necessary) and enter the value for the respective vertex value ( $L_{-1}$  to  $L_{11}$ ) in physical variables in the structuring mode oFPA.

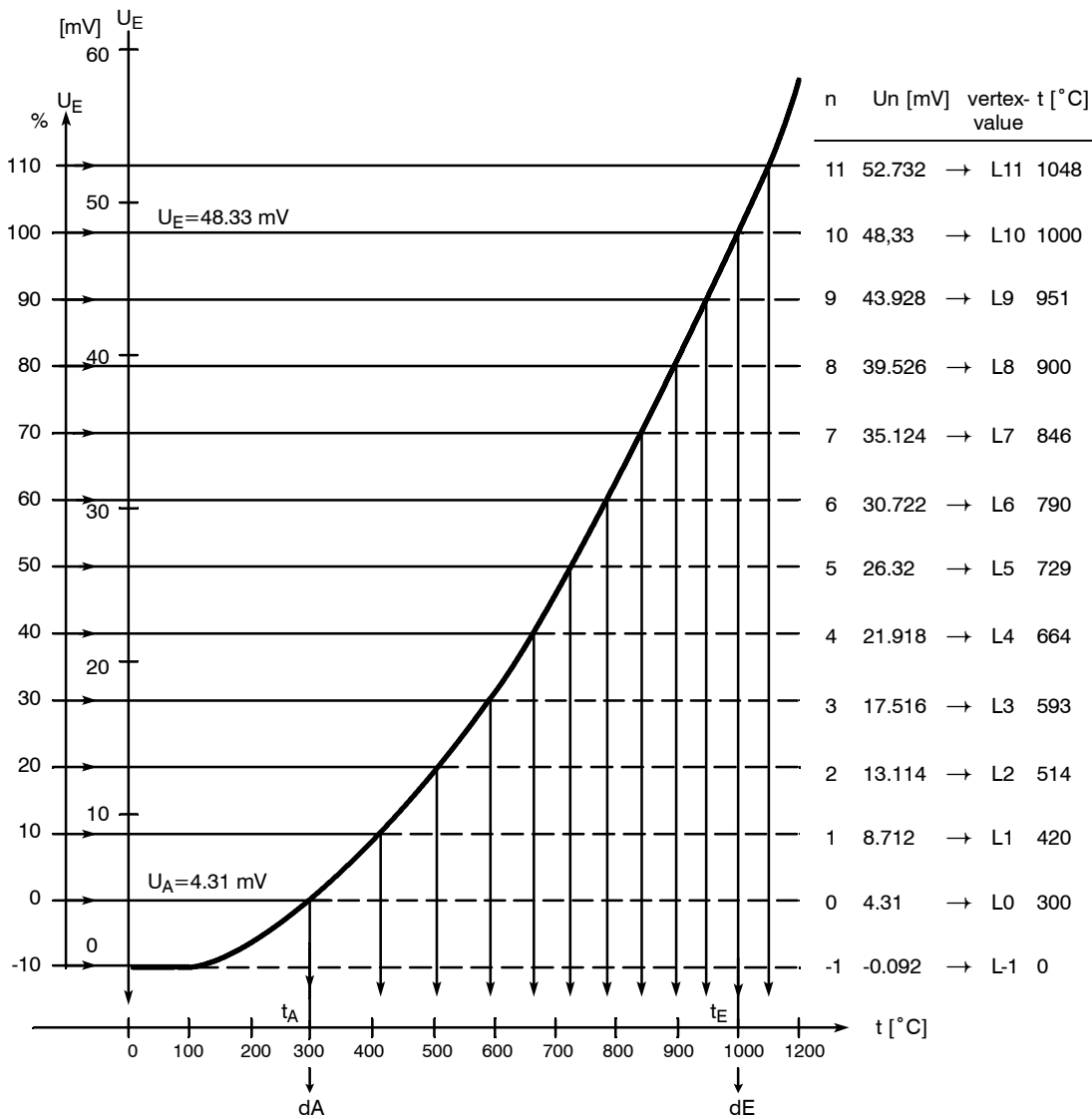

Figure 3-35 Example of linearization of a thermocouple type B Pt30Rh/Pt6, measuring range dA to dE from 300 to 1000 °C

### 3.10.5 Restart conditions (S82, S83)

The restart conditions after mains recovery are determined with S82. With S82 = 0 the controller starts after mains recovery and after a watch-dog-reset with the operating mode and with the y which was active before the power failure. This variation must be used when temporary mains failures are to be expected in slow control circuits.

With S82 = 1 starting after mains recovery takes place in manual- and in internal operation with ys in the K-controller (S2 = 0) and two-position controller (S2 = 1) or with the last y in the three-position controller (S2 = 2, 3). If only external operating mode or only automatic operation was selected by S42 = 1 or S51 = 1 respectively, the restart takes place in these operating modes.

With S83 the optical signaling of mains voltage recovery and reset is determined by flashing of the digital x-display. The flashing is acknowledged by pressing the Shift key (6) or by an alarm request via SES.

### 3.10.6 Serial interface and PROFIBUS-DP (S84 to S91)

The structure switch determines whether operation is with SES (S84 = 1/2/3<sup>\*)</sup>) or without SES (S84 = 0) (see also "Control system coupling via the serial interface", page 109).

With S85 the depth of the SES-interventions is preset. Generally all available set data are read. In position 0 no transmission and reception of data to the controller is possible. In position 1 only parameters and structures can be transmitted. In positions 2 to 5 the process variables  $w_{ES}$  (external setpoint via the SES),  $w_{iES}$  (internal setpoint via the SES),  $y_{ES}$  (external manipulated variable via the SES),  $y_{HES}$  (manual manipulated variable via the SES) and all control signals can be sent additionally via the SES. At the same time, S85 switches over the sources for the external setpoint  $w_{ES}$  or  $w_{EA}$  and for the tracking manipulated variable  $y_{ES}$  or  $y_N$ . This makes it possible to preset the process variables and the control signals only via the SES or the process variables analogly and only the control signals via the SES.

With S84 = 1/2 writing of status signal  $S_{iES}$  to  $tSH_{ES}$  can be locked via /RC or CB.

The structure switches S86 to S91 determine the transmission procedure through the serial interface. See the user guide "Serial SIPART DR21 Bus Interface" for explanations; Internet address: [www.fielddevices.com](http://www.fielddevices.com) [Edition 05.2000].

Settings for PROFIBUS-DP see table 5-5, page 172 (structure switch list).

<sup>\*)</sup> as of software version C1



## 4 Installation

### 4.1 Mechanical Installation

- **Selecting the Installation Site**

Maintain an ambient temperature of 0 to 50 °C. Don't forget to allow for other heat sources in the vicinity. Remember that if instruments are stacked on top of each other with little or no gap between them, additional heat will be generated. The front and rear of the controller should have good accessibility.

#### 4.1.1 Work prior to installation

The controller type 6DR2100-5 is set to 230 V AC mains voltage in the as-delivered state. The switching contacts are locked. The backplane module must be removed to change the mains voltage setting or to unlock the relay contacts.

- **Removing the backplane module**



#### CAUTION

The backplane module may only be removed when the mains plug and the 3-pin  $\pm \Delta y$ -plug have been removed!

Loosen the fastening screw (6) and pull the module out from the back.

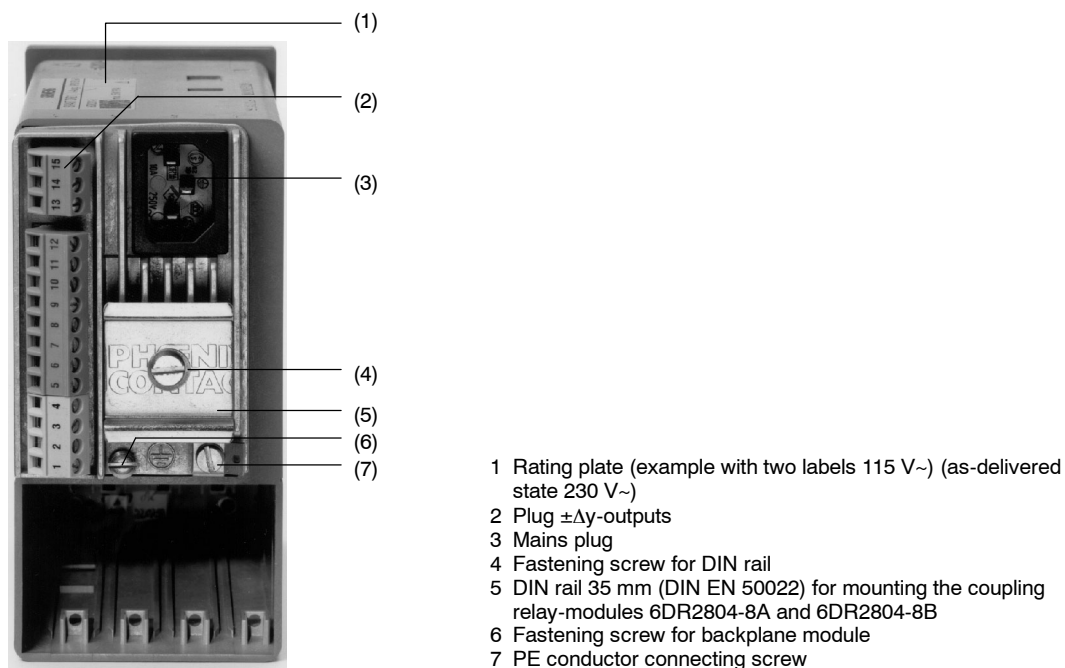

Figure 4-1 Rear of controller

- **Switching mains 230 V to 115 V**

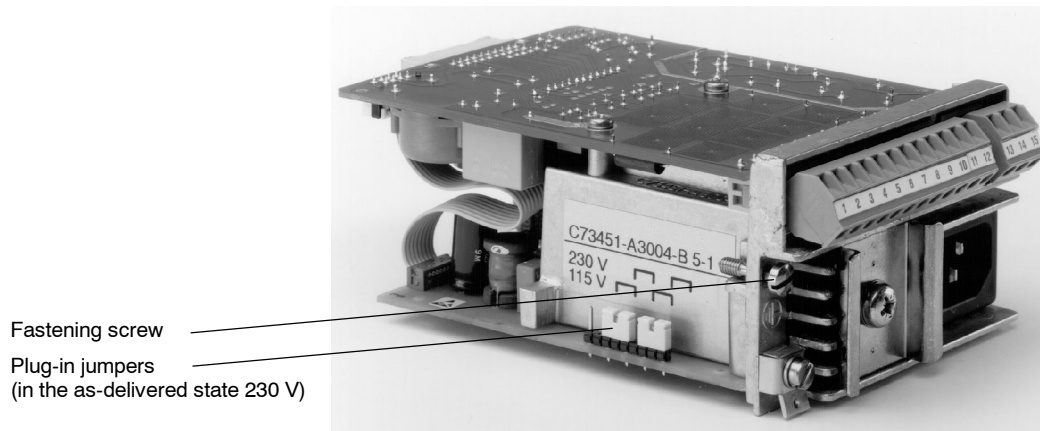

Figure 4-2 Setting the mains voltage

Re-plug jumpers as shown in the diagram in figure 4-2. Stick the two labels provided (115 V power supply) to the rating plate in the field 230 V AC and on the housing to the right of the mains plug vertically to the rear of the housing (see figure4-1). Re-install the backplane accordingly.

- **Unlock the relay contacts**

Re-plug the plug-in jumper (figure 4-4, page 123) to unlock.

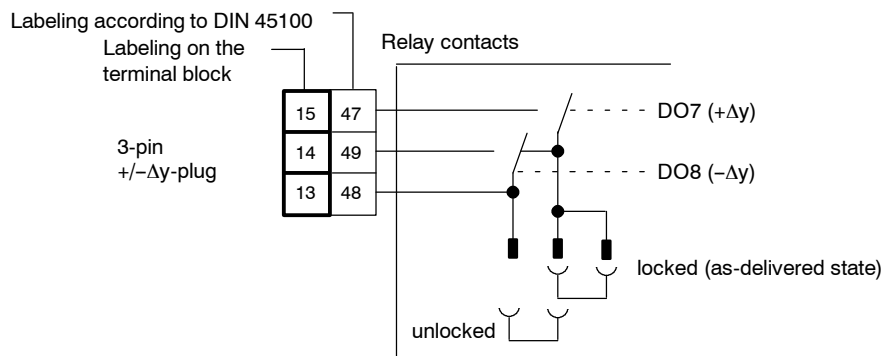
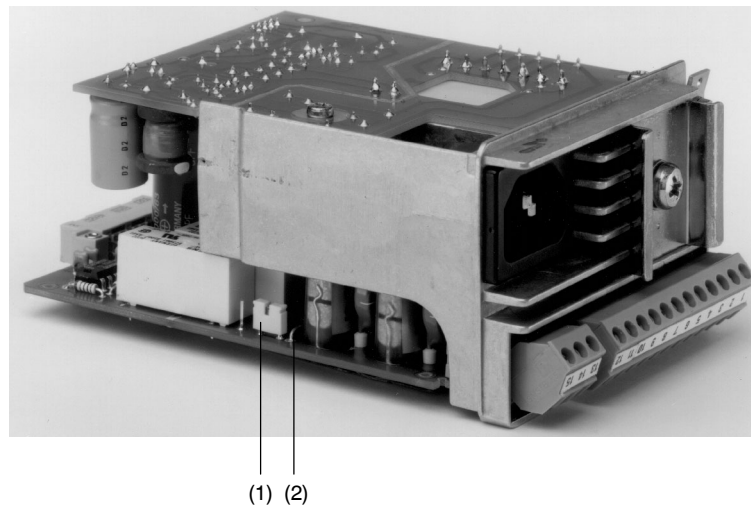

Figure 4-3 Circuit



- (1) as-delivered state (locked)  
(2) Spark quenching element Adapt resistance to connected contacts or servo motors if necessary.

Figure 4-4 Relay contact locking

Re-install the backplane accordingly.

- **Changing the tag plate and scales**  
**(Please observe the “correct procedure”!)**

The tag plate and scales can be labeled individually on the back with a smear-proof pen.

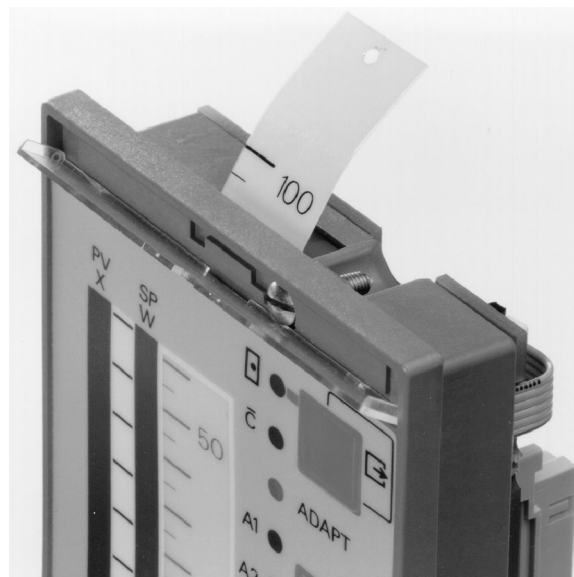

Figure 4-5 Tag plate

### Procedure / removing the front module

- Remove the mains module and any modules which may be plugged in.
- Turn the controller so that you are looking at the operating- and display front module from the front.
- Carefully lever out the tag plate cover with a screwdriver at the cutout at the top and snap the cover out of the bottom hinge points by bending slightly. Loosen the screw (captive) Tilt the top of the front module at the head of the screw and pull it out angled slightly forwards.
- The scales can now be removed from the narrow side of the operating- and display front module with a pair of tweezers.

## 4.1.2 Installing the controller

### ● Panel mounting

The SIPART DR21 controllers are installed either in single panel cutouts or in open tiers (dimensions, see figure 2-6, page 35).

Procedure:

- If necessary: Push the self-adhesive sealing ring for sealing the front frame/front panel over the tube and stick to the back of the tube collar.  
(to be ordered separately)
- Insert the controller into the panel cut-out or open tier from the front and fit the two clamps provided to the controller unit from the rear so that they snap into the cut-outs in the housing.
- Align the controller and do not tighten the locking screws too tight. The tightening range is 0 to 40 mm.

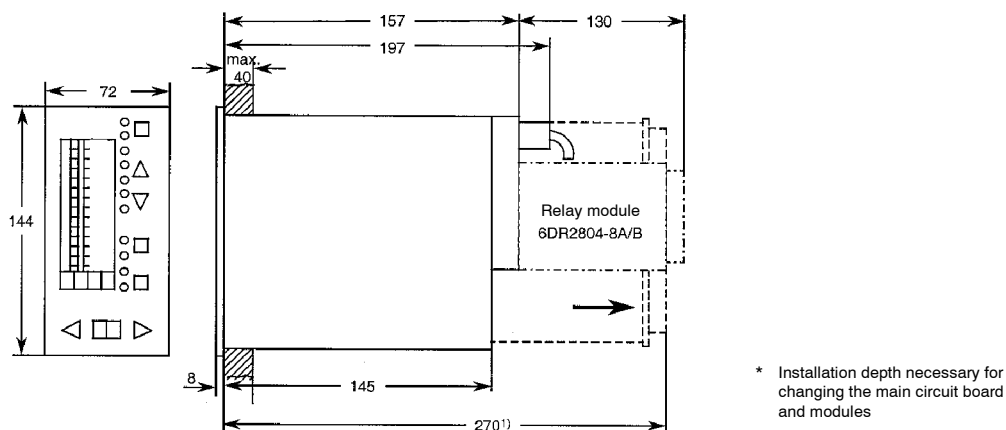

Figure 4-6 Dimensions SIPART DR21, dimensions in mm

### 4.1.3 Installation of the options modules

#### General

Signal converter modules can be inserted in the slots provided in the SIPART DR21 controller from the rear. The slots are coded to avoid plugging the modules incorrectly.

#### Jumper settings

Jumpers may have to be set on the modules I/U, R, SES (figure 4-7) before they are plugged into the controller.

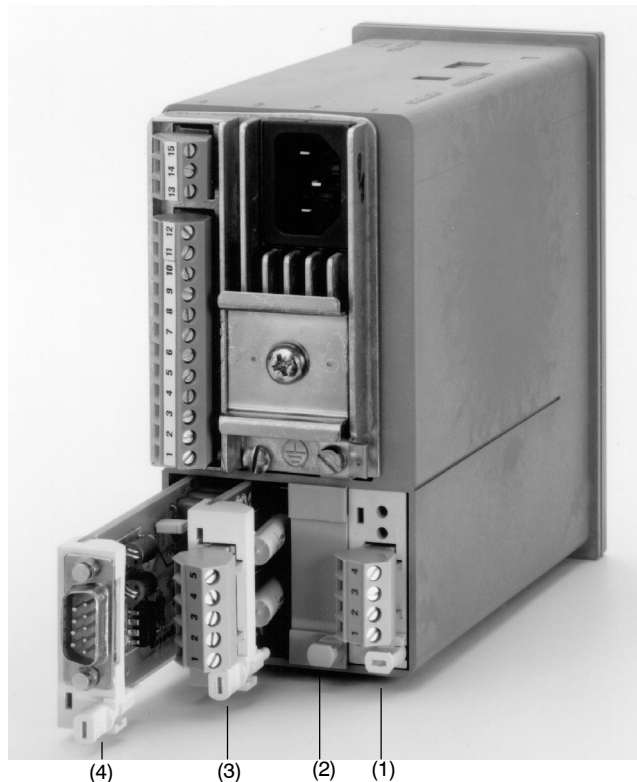

- |            |                                  |
|------------|----------------------------------|
| (1) Slot 1 | AI3 (UNI, I/U, R)                |
| (2) Slot 2 | AI4 (UNI, I/U, R)                |
| (3) Slot 3 | 5DI; 2DI 4DO; 2DO rel.           |
| (4) Slot 4 | SES (serial interface, PROFIBUS) |

Figure 4-7 Rear of controller

---

## 4.2 Electrical Connection

### 4.2.1 Warnings and block diagram

The arrangement of the connecting elements can be seen in figure 4-7, page 125.



---

#### **WARNING**

The "Regulations for the installation of power systems with rated voltages under 1000 V" (VDE 0100) must be observed in the electrical installation!

---

- **PE conductor connection**

Connect the PE conductor to the ground screw (see figure 4-8, page 128) on the back of the controller. When connecting to 115 or 230 V AC-mains supply, the PE conductor can also be connected through the three-pin plug (see figure 4-9, page 129). The controller's ground-connection may also be connected with the PE conductor (grounded extra low voltages).



---

#### **WARNING**

Disconnection of the PE conductor while the controller is powered up can make the controller potentially dangerous. Disconnection of the PE conductor is prohibited.

---

- **Power supply connection**

The power supply is connected on 115 V AC or 230 V AC systems by a three-pin plug IEC 320/V DIN 49457 A, on 24 V UC systems by a special 2-pin plug (polarity irrelevant). The mains plugs are part of the scope of delivery.



---

#### **WARNING**

Set the mains voltage plug-in jumpers (see figure 4-2), page 122 in the no-voltage state to the existing mains voltage.

It is essential to observe the mains voltage specified on the rating plate or by the mains voltage jumpers (115/230 V AC) or on the voltage plate (24 V UC)! Lay the power cable through a fuse; limit the rating (fire protection EN 61010-1) to  $\leq 150$  VA. Limit the mains voltage alternatively to 30 V at 24 V UC.

---

- **Connection of measuring- and signal lines**

The process signals are connected via plug-in terminal blocks that can accommodate cables of up to 1.5 mm<sup>2</sup> (AWG 14) cross-section.

Standard controller	Terminal block 1, 2, 3	3-pin	S-outputs
		4-pin	AI1, AI2
		8-pin	AO, DI, DO, L+, GND
Options modules	Slot 1 and 2	4-pin	for analog input modules
	Slot 3	6-pin	for digital I-O-modules
	Slot 4	9-pin	for interface module

The coupling relay module should be snapped onto the DIN rail (figure 4-7, page 125) and wired to the digital outputs.

Slots 1 to 4 must be identified in the circuit diagrams. Makes sure that the module-terminal blocks are not switched.

Measuring lines should be laid separately from power cables to avoid the risk of interference couplings. If this is not possible, or – due to the type of installation – the controller may not function properly as a result of interference on the measuring lines, the measuring lines must be shielded. The shield must be connected to the PE conductor of the controller or one of the ground-connections, depending on the fault source's reference point. The shield should always only be connected to one side of the controller when it is connected to the PE conductor to prevent creation of a ground loop.

The SIPART DR21 is designed with a high electromagnetic compatibility (EMC) and has a high resistance to HF-interference. In order to maintain this high operational reliability we automatically assume that all inductances (e.g. relays, contactors, motors) installed in the vicinity of or connected to the controllers are assembled with suitable suppressors (e.g. RC-combinations)! To dissipate interference, the controller must be connected at the PE-terminal of the cast body (figure 4-8, page 128 item 5) with good HF-conductance.

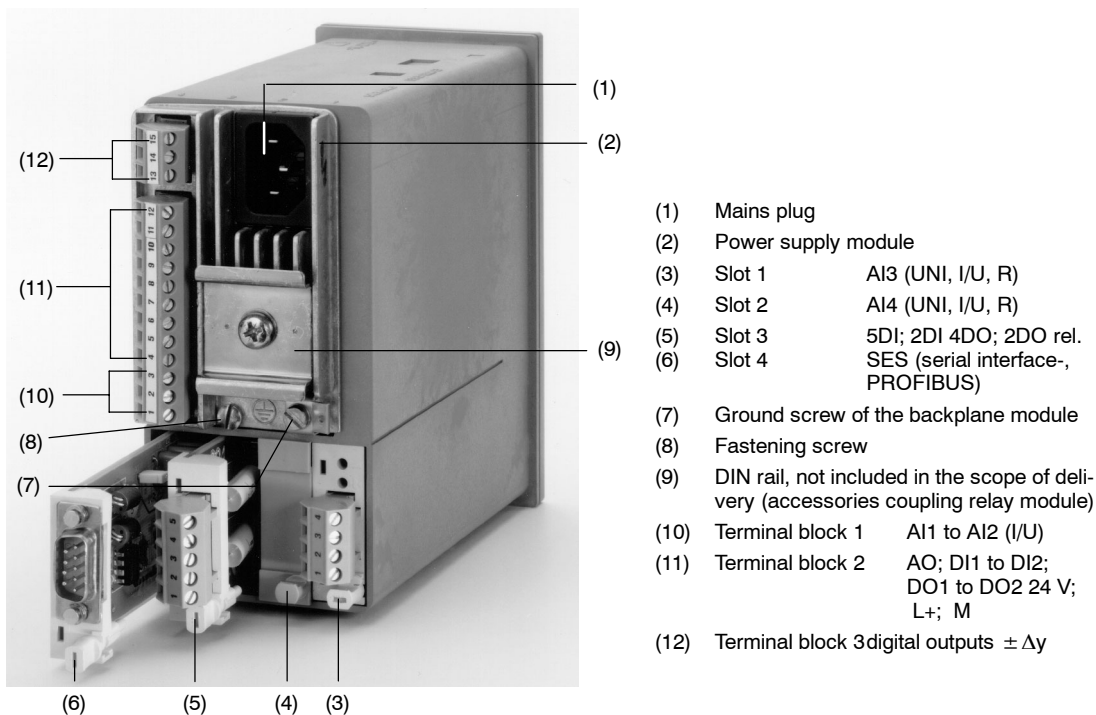

Figure 4-8 Controller backplane with terminal assignment of the standard controller



**NOTE**

The screw-type terminal blocks for connecting the process signals to the controller are of the plug-in type.

● **Zero-Volt-system**

The SIPART DR21 controllers only have a 0V-conductor (ground, GND) on the process side which is output double at terminals 11 and 12 of the standard controller. If these GND-connections are not sufficient, additional proprietary terminals can be snapped onto the DIN rail on the power pack. The controller uses a common GND-conductor for both inputs- and outputs, all process signals are referred to this point.

The GND-connection is also connected to vacant terminal modules. These may only be used if practically no input current flows through this connection (see e.g. figure 4-17, page 133).

The power supply connection is electrically isolated from the process signals. In systems with unmeshed control circuits, the SIPART DR21s need not be interconnected. In meshed control circuits the GND-connections of all controllers must be fed singly to a common termination or the continuous GND-rail with a large cross-section. This common termination may be connected with the system's PE conductor only at one point.

The signal current is tapped at the analog signal inputs by a four-pole measurement on the input measuring resistor. Voltage dips on the supply lines therefore have no effect. In the case of digital signals, the signal-to-noise ratio is so great that voltage dips on the GND-rail can be ignored.



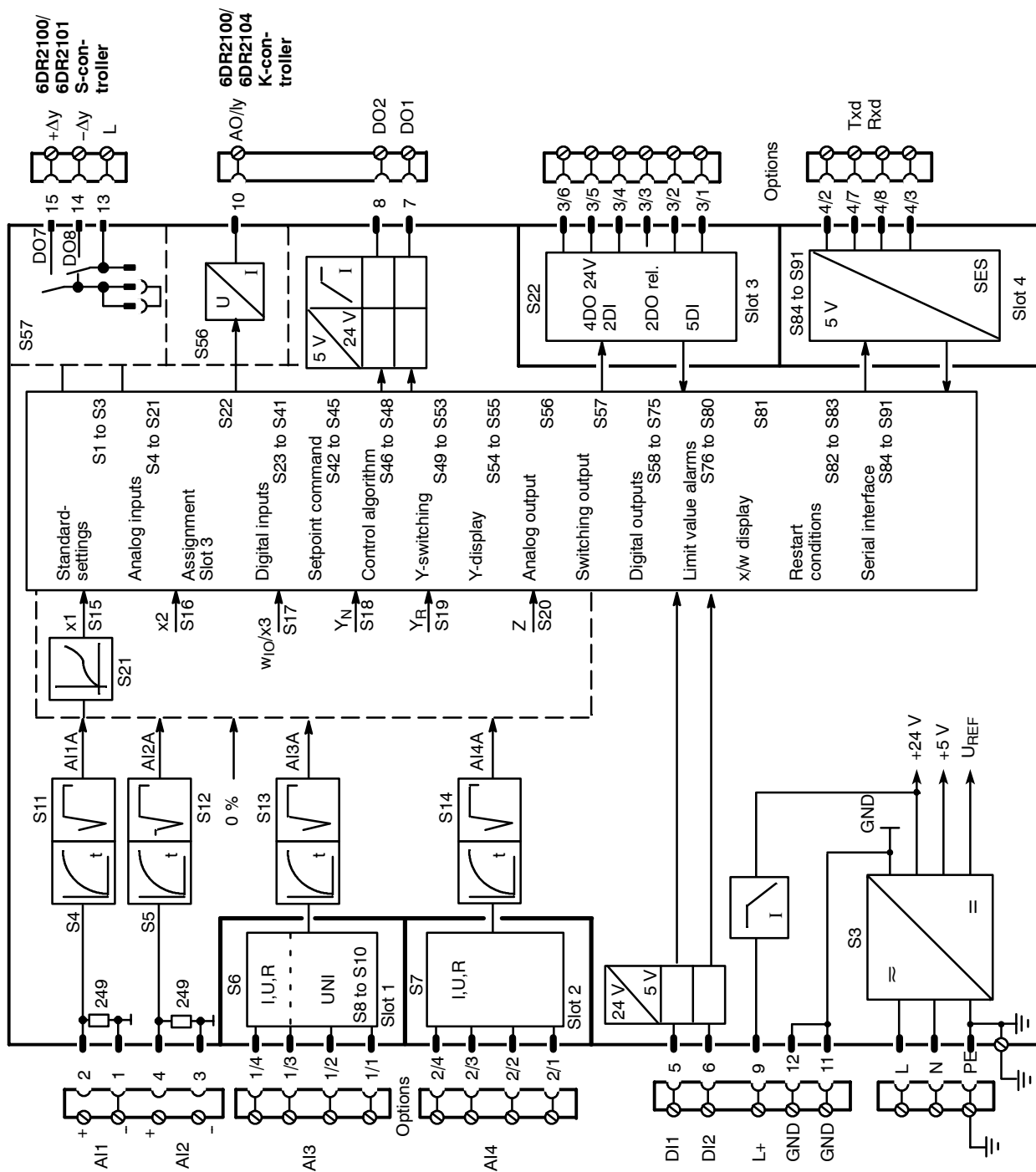

Figure 4-9 Block diagram SIPART DR21

## 4.2.2 Connection standard controller

### • Power supply connection



#### CAUTION

Pay attention to mains jumpering (see figure 4-2, page 122)!

#### - 6DR210x-5 (115/230 V AC)

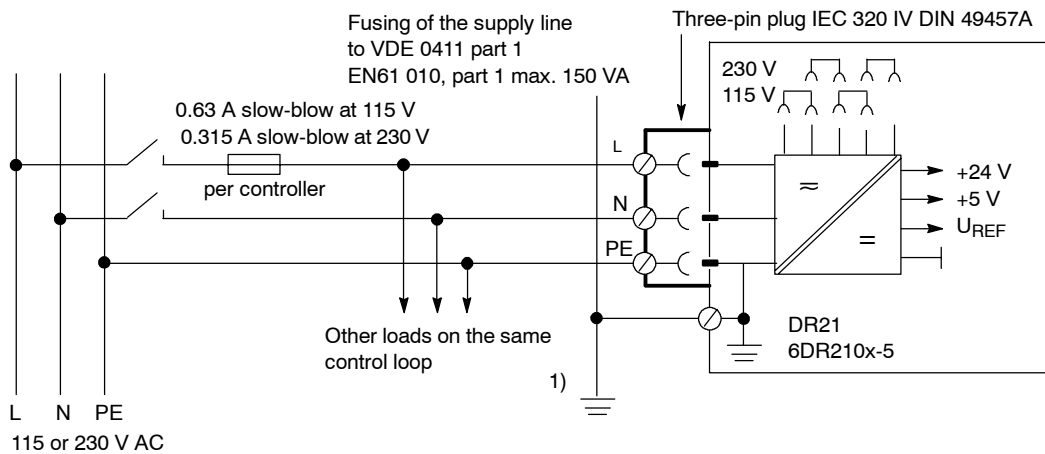

Figure 4-10 Connection 115/230 V AC power supply

#### - 6DR210x-4 (24 V UC)

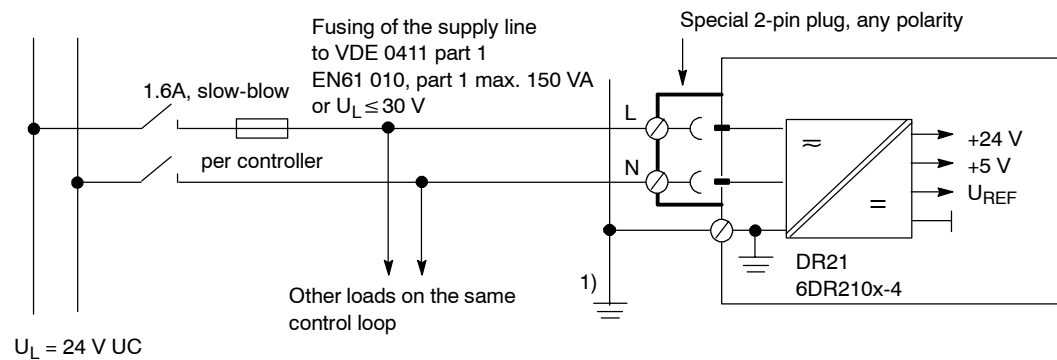
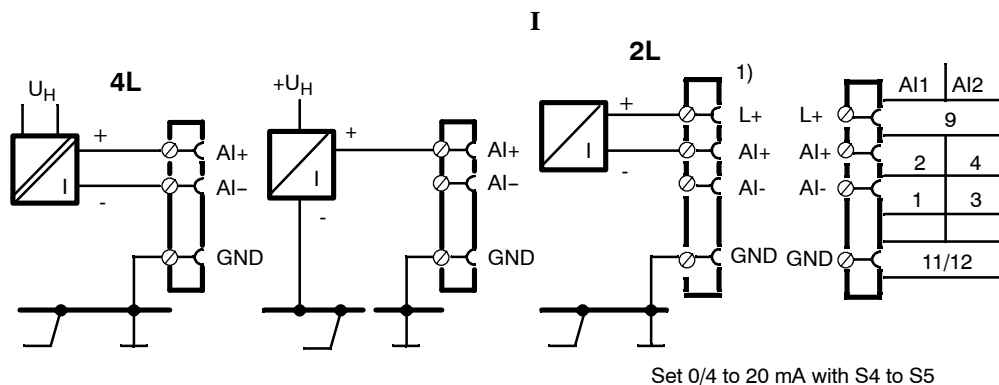

Figure 4-11 Connection 24 V UC power supply

- 1) The connection between the PE conductor screw (figure 4-8, item 5, page 128) to ground must be established additionally for high electromagnetic compatibility (EMC) in 115/230 V-controllers. This connection must also be low resistive for high frequencies (Cu-band or Hf-strand). Alternatively at least 2.5 mm<sup>2</sup> flexible should be used.

● Connection of measuring- and signal lines AI1 and AI2



1) The series circuiting of several inputs is not possible because AI1/2 is connected internally to GND.

Figure 4-12 Wiring AI1 to AI2, current inputs

● DI1 to DI2

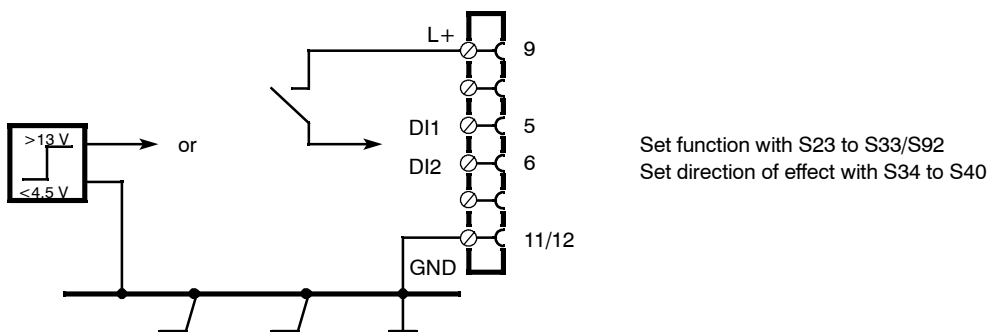

Figure 4-13 Connection DI1 to DI2

● AO

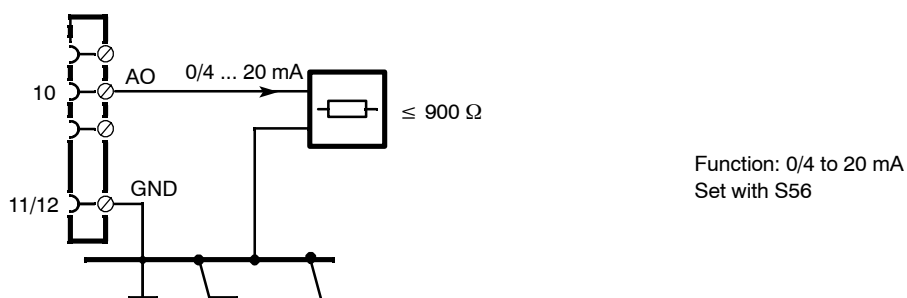
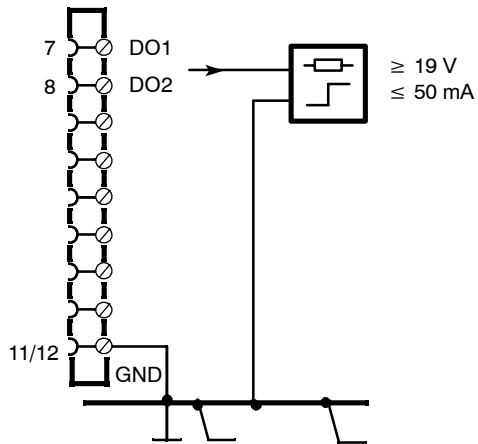

Figure 4-14 Connection AO

● **DO1 to DO2**



Set function with S58 to S68  
Set direction of effect with S69 to S75

Figure 4-15 Connection DO1 to DO2

● **L+ (auxiliary voltage output)**

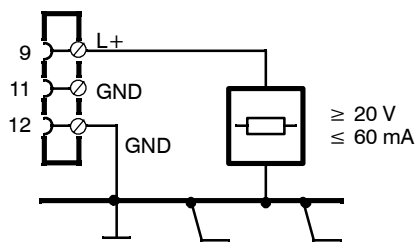

Figure 4-16 Connection L+

### 4.2.3 Connection of the options modules

#### 4.2.3.1 Modules for analog measuring inputs

- **6DR2800-8J (U or I-input)**

Set AI3 in slot 1 with S6 } measuring range 0 to 1 V, 10 V, 20 mA or  
AI4 in slot 2 with S7 } 0.2 V, 2 V, 4 mA to 1 V, 10 V, 20 mA

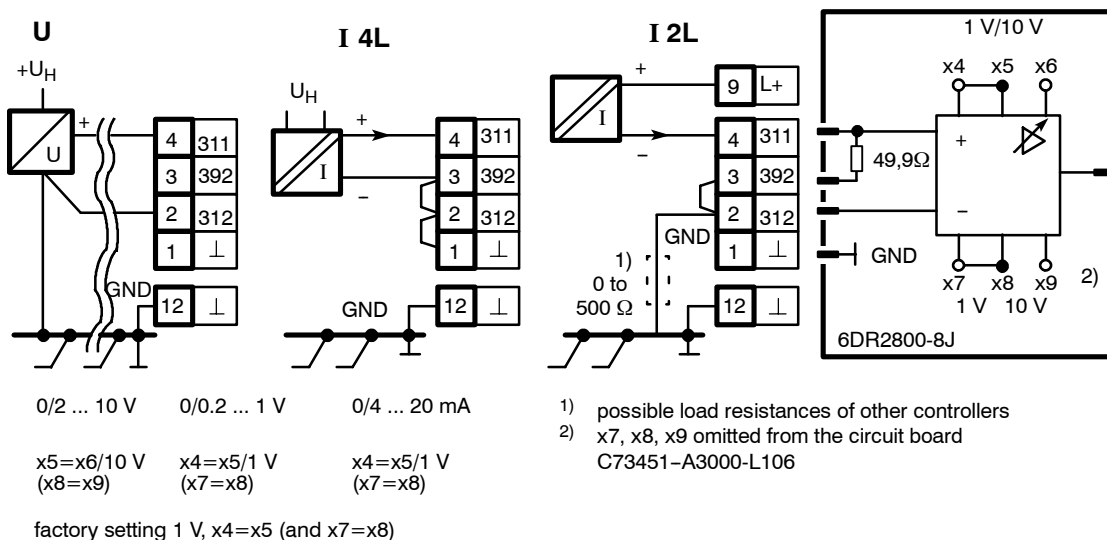

Figure 4-17 Connection U/I-module 6DR2800-8J

● **6DR2800-8R (resistor input)**

Set AI3  $\underline{\Delta}$  slot 1; S6 = 0 or 1  
Set AI4  $\underline{\Delta}$  slot 2; S7 = 0 or 1

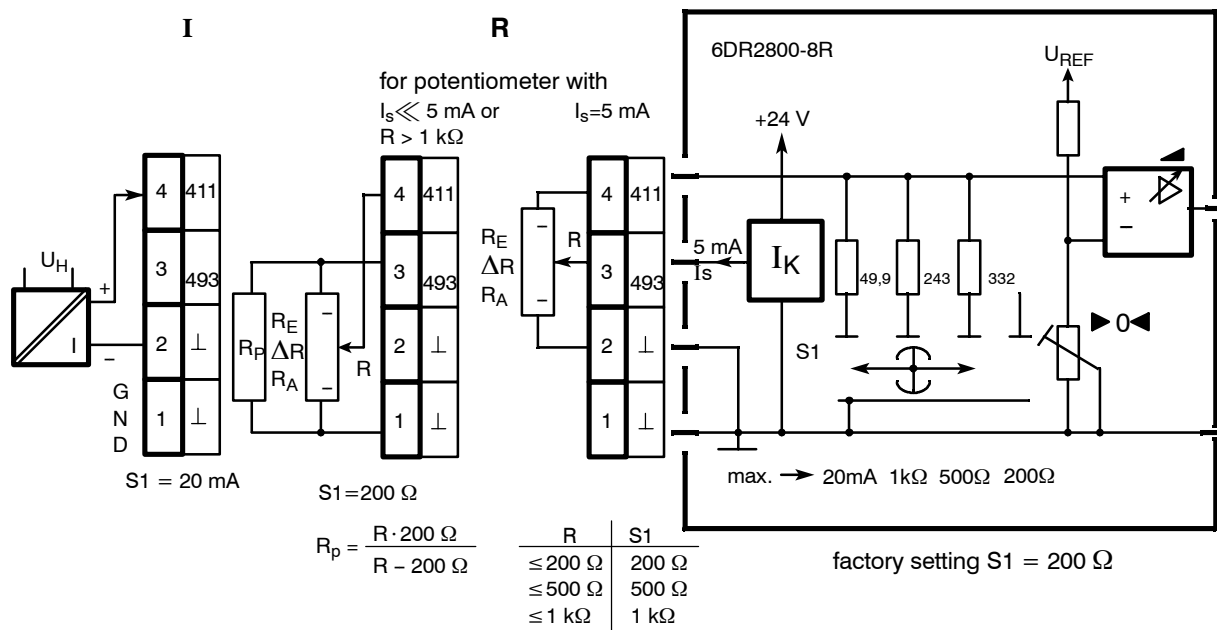

Figure 4-18 Connection R-module 6DR2800-8R

- **Calibration**

1. Slide switch or plug-in jumper S1 according to measuring range
2. Set  $R_A$  with  $\blacktriangleright 0 \blacktriangleleft$  display or analog output (structured accordingly) to start value or 4 mA.
3. Set  $R_E$  with  $\blacktriangleleft$  display or analog output to full scale value or 20 mA.

● **6DR2800-8V (universal module for analog input)**

The universal module can only be inserted in slot 1. It is assigned to AI3 with S6 > 3 and structured with S8, S9, S10.

The measuring ranges are set with the menu CAE3 (see chapter 5.4.6, page 173).

- **Connector pin assignment for mV-transmitter S8 = 0**

Direct input  $U_{max} = \pm 175 \text{ mV}$

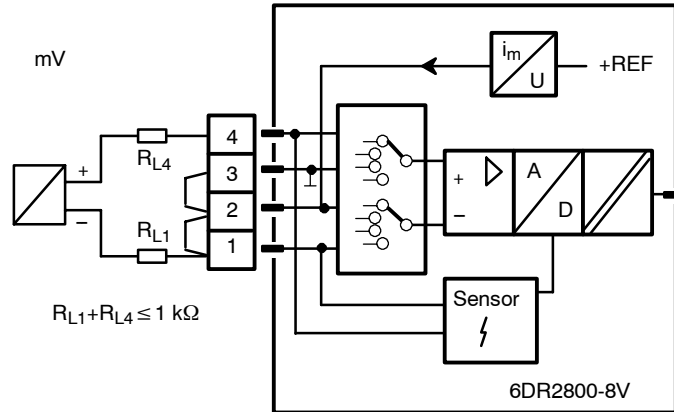

Block diagram mV-module 6DR2800-8V

Figure 4-19 Connection UNI-module AE3 S8=0

- **Pin assignment measuring range plug 6DR2805-8J for U or I S8 = 0**

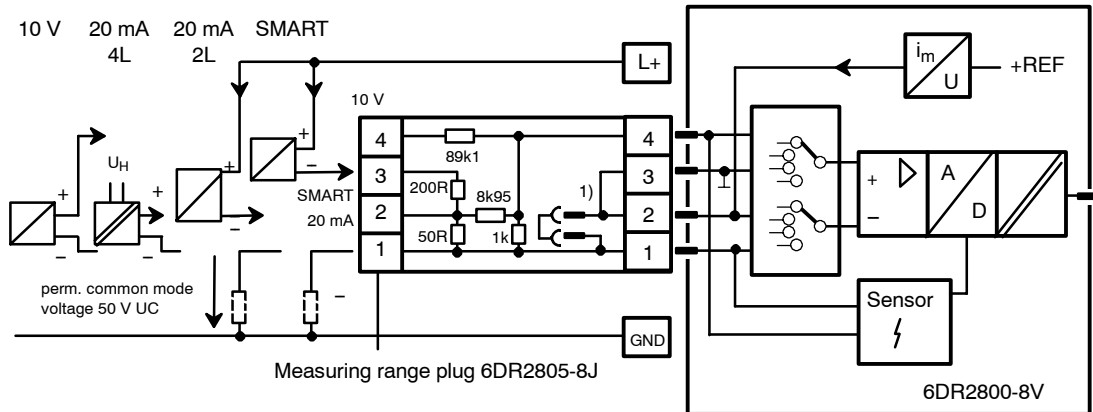

1) DR21: Jumper must be plugged

Block diagram mV-module 6DR2800-8V

Figure 4-20 Connection UNI-module AE3 S8=0 with measuring range plug

- Pin assignment for thermocouple TC S8 = 1, 2

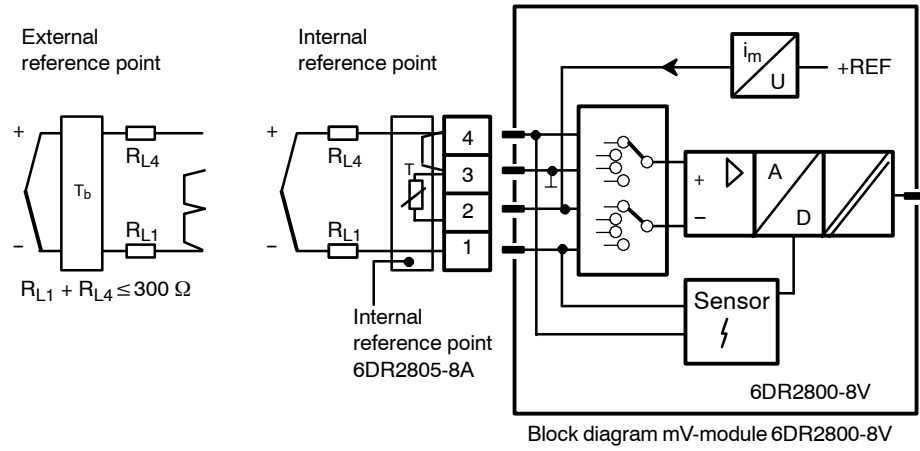

Figure 4-21 Connection UNI-module AI3 S8 = 1, 2

- Pin assignment for Pt100-sensor RTD S8 = 3, 4, 5

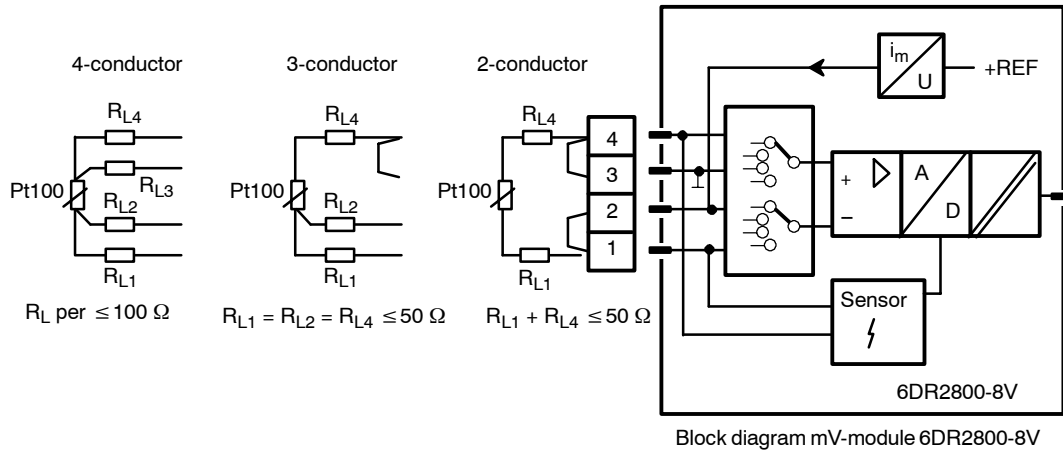
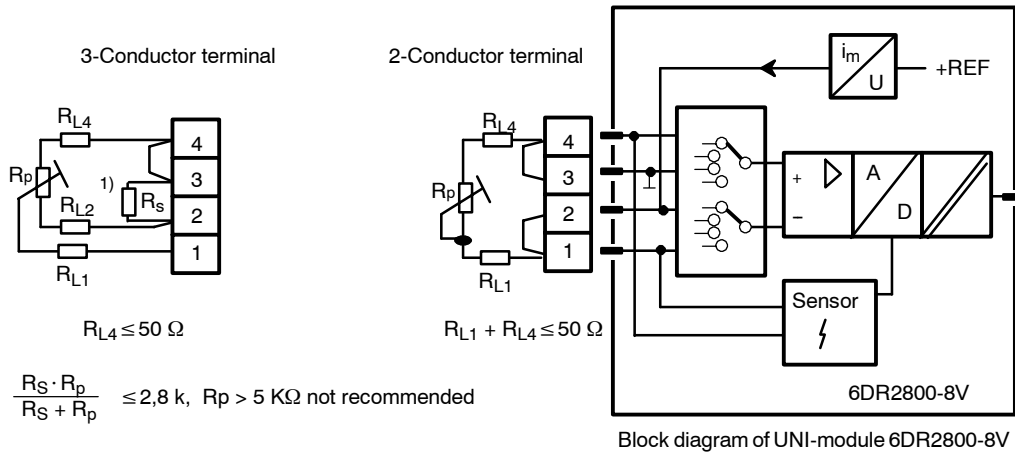

Figure 4-22 Connection UNI-module AI3 S8 = 3, 4, 5



- Pin assignment for resistance potentiometer R S8 = 6, 7



1)  $R_s$  Shunt impedance only necessary if  $2.8 \text{ k}\Omega < R \leq 5 \text{ k}\Omega$

Figure 4-23 Connection UNI-module AI3 S8 = 6, 7

4.2.3.2 Connection examples for analog measuring inputs with the module 6DR2800-8J

In current inputs the input load resistance is between AI+ and AI-.

If the signal is still required during service work in which the terminal is disconnected, the input load resistance must be connected to the terminal between AI+ and AI-. The internal  $49.9 \Omega$  resistance must then be disconnected in 6DR2800-8J by appropriate rewiring.

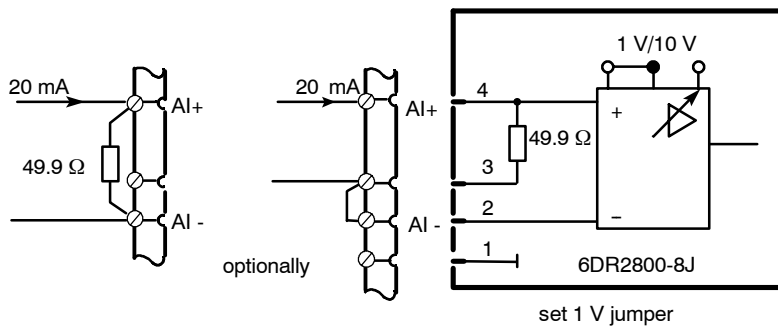

Figure 4-24 Current input via options modules, internal or external  $49.9 \Omega$  resistance

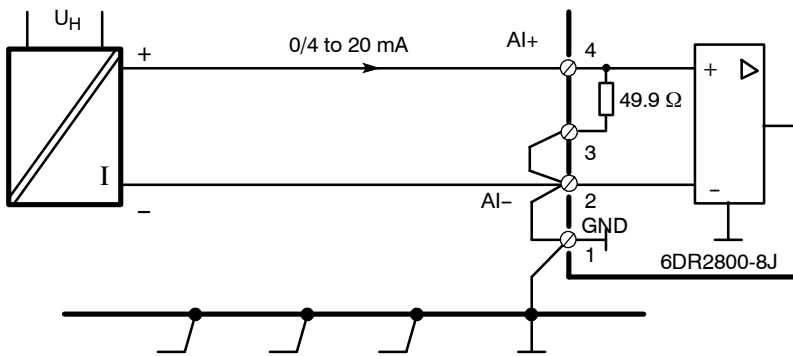

Figure 4-25 Connection of a 4-wire-transmitter 0/4 to 20 mA with potential isolation

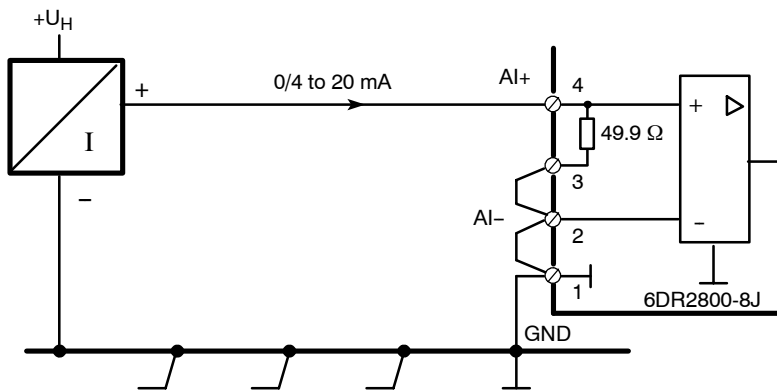

Figure 4-26 Connection of a 0/4 to 20 mA 3-wire transmitter with negative polarity to ground

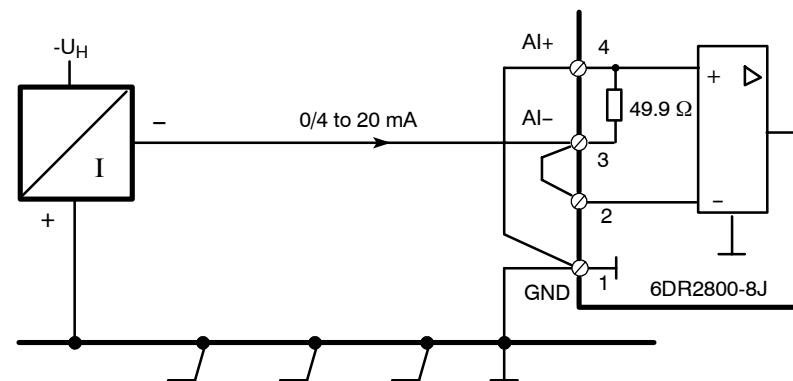

Figure 4-27 Connection of a 0/4 to 20 mA 3-wire transmitter with positive polarity to ground

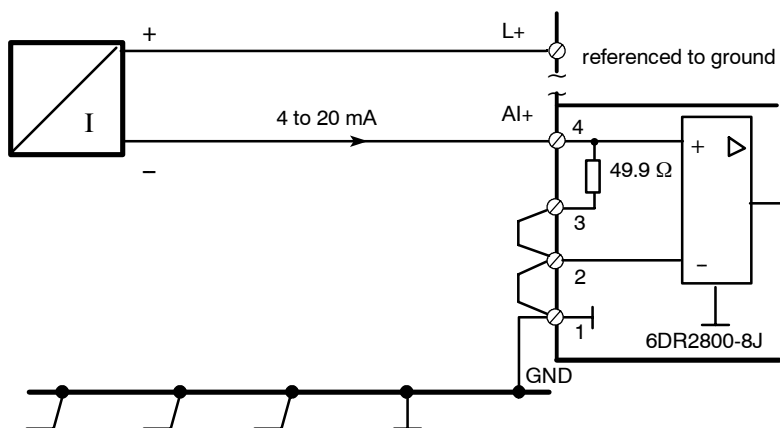

Figure 4-28 Connection of a 4 to 20 mA 2-wire transmitter supplied from controller's L+

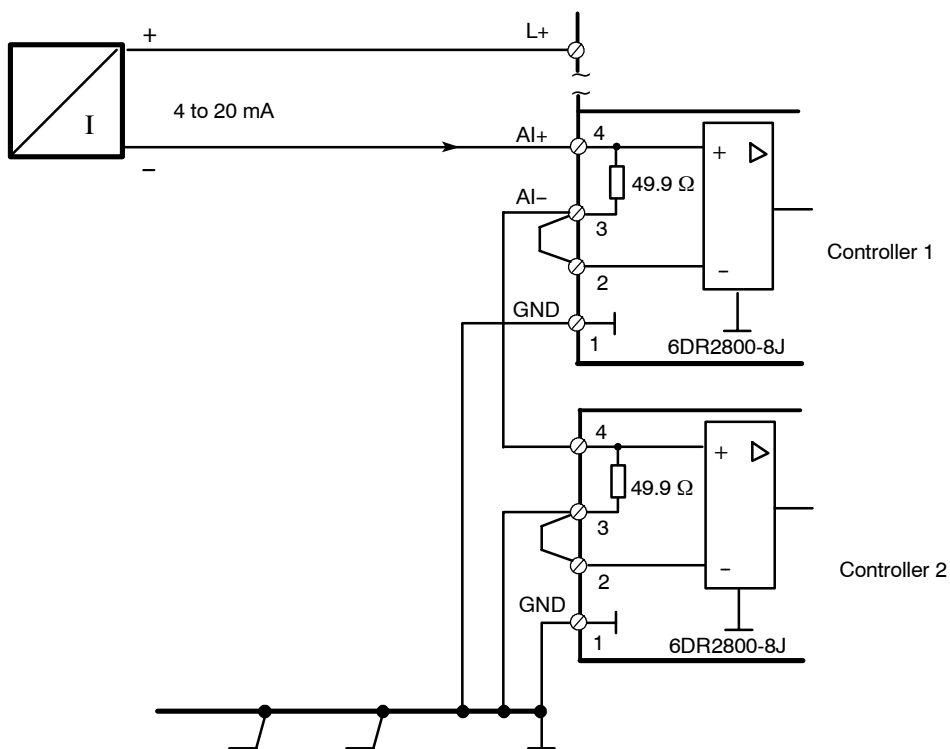

Figure 4-29 Connection of a 4 to 20 mA 2-wire-transmitter to two instruments in series supplied by L+ from one of the instruments

Every input amplifier is supplied by a differential input voltage of 0.2 to 1 V. The input amplifier of controller 1 has an additional common mode voltage of 0.2 to 1 V which is suppressed. Several instruments with a total common-mode voltage of up to 10 V can be connected in series. The last controller referenced to ground may also have a ground referenced input load (e.g. AI1 or AI2 of SIPART DR21).

The permissible load voltage of the transmitter must be observed in series circuiting of load resistors.

• Voltages 0/0.2 to 1 V or 0/2 to 10 V

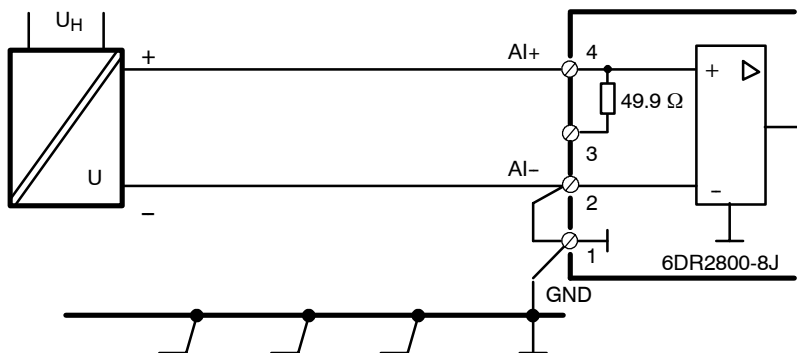

Figure 4-30 Connection of a floating voltage supply

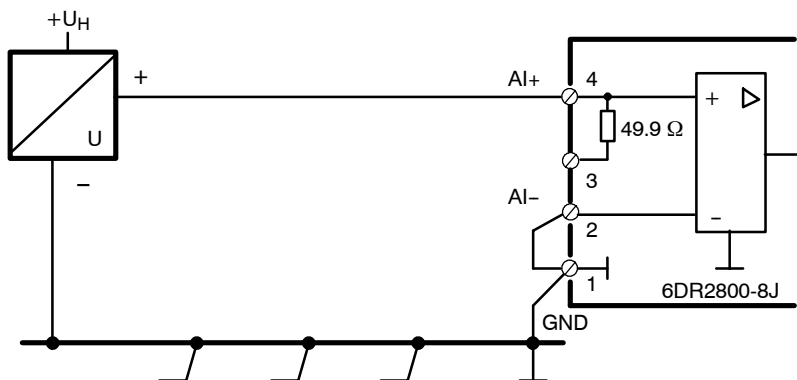
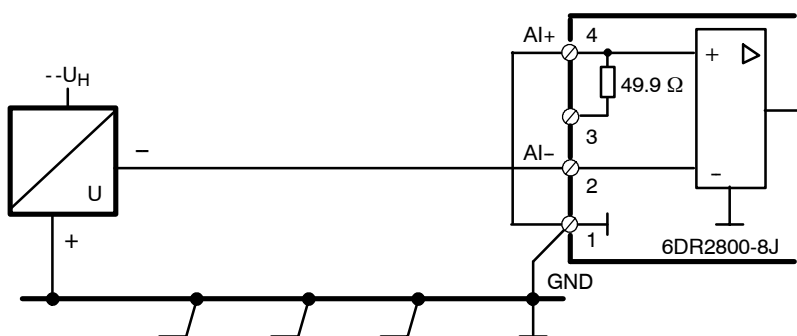

Figure 4-31 Single-pin connection of a non-floating voltage supply with negative polarity to ground



only permitted when  
connected for 1 V

Figure 4-32 Single-pin connection of a non-floating voltage supply with positive polarity to ground

Figure 4-31 and figure 4-32:

The voltage dip on the ground-rail between the voltage source and the input amplifier appears as a measuring error. Only use when ground cables are short or choose a circuit configuration as shown in figure 4-33, page 141!

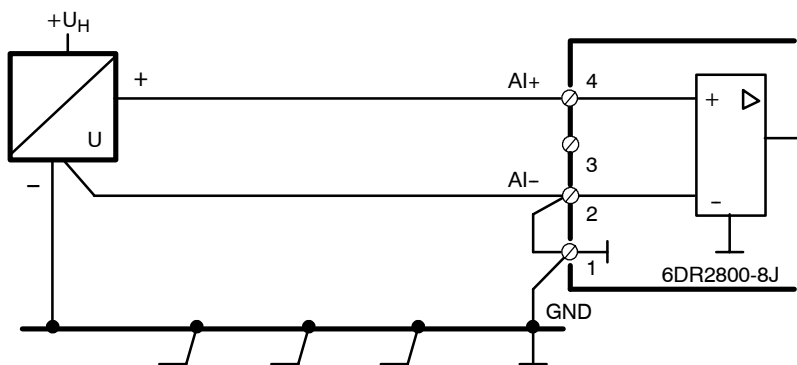

Figure 4-33 Double-pin wiring of a voltage source with negative polarity to ground

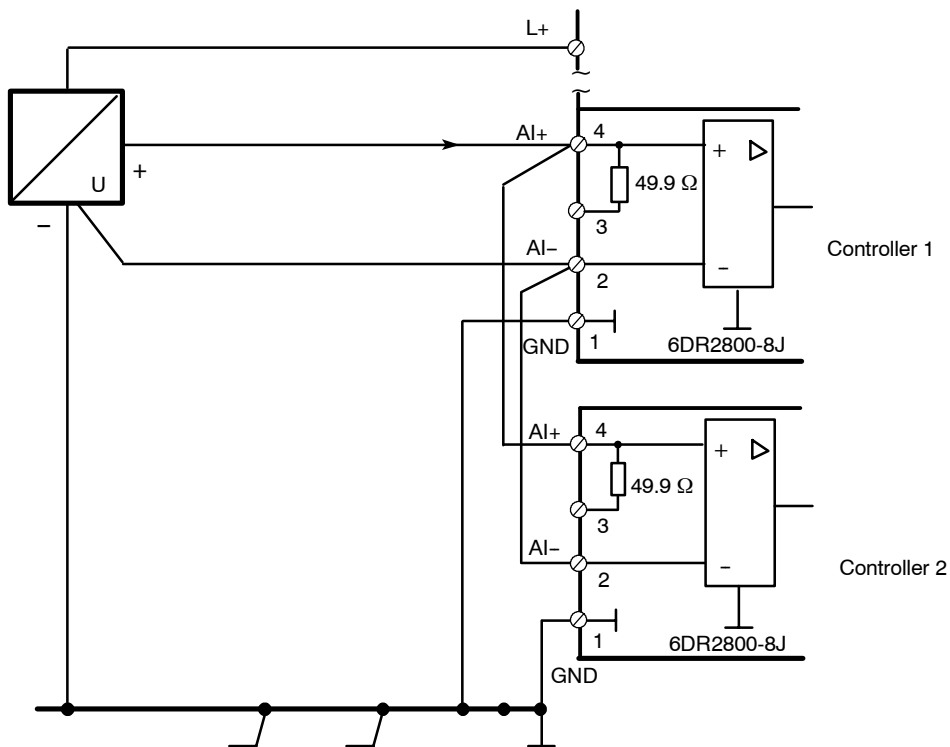

Figure 4-34 Parallel wiring of a non-floating voltage source to two instruments.  
The voltage source is supplied by L+ of one of the instruments and negative is referred to ground.

Figure 4-33 and figure 4-34:  
The voltage dip on the ground-rail between the voltage source and the input amplifier appears as a common mode voltage and is suppressed.

### 4.2.3.3 Modules for expanding the digital inputs and digital outputs

- **6DR2801-8C (5DI)**

DI3 to 7 in slot 3 (S22 = 2)

Set function with S23 to S33

Set direction of effect with S34 to S40

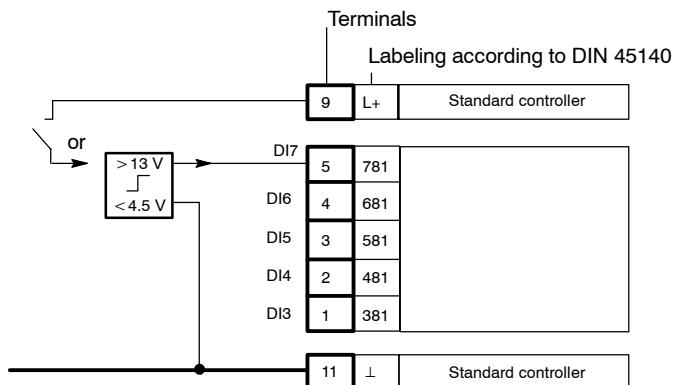

Figure 4-35 Wiring of 5DI module 6DR2801-8C

- **6DR2801-8E (4DO 24 V + 2 DI)**

DO3 to DO6 in slot 3 (S22 = 1)

Function

DO with S58 to S68

DI with S23 to S33

Direction of effect

DO with S69 to S75

Set DI with S34 to S40

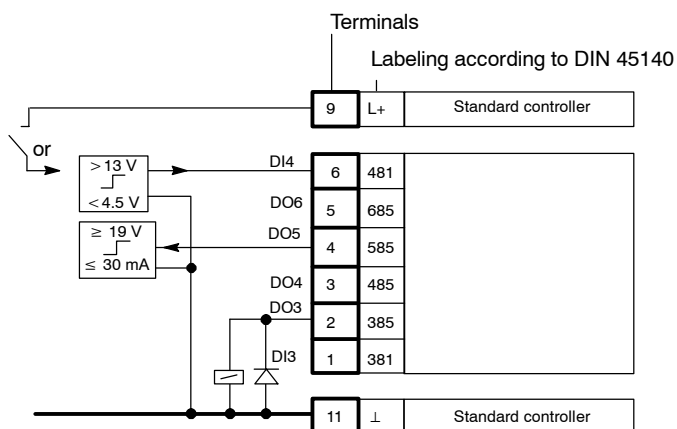

Figure 4-36 Connection of 4DO (24 V)-module 6DR2801-8E

● **6DR2801-8D 2DO relay 35 V**



**WARNING**

The relay contacts are only permitted for switching voltages up to UC 35 C.

DO3 and DO4 in slot 3 (S22 = 2) Set function with S58 to S68  
Set direction of effect with S69 to S75

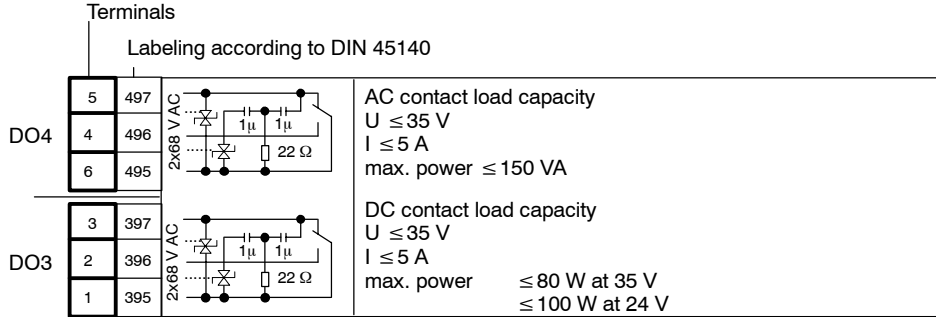

Figure 4-37 Connection of 2DO (relay) -module 6DR2801-8D

● **6DR2804-8A (coupling relay 230 V, 4 relay)**  
**6DR2804-8B (coupling relay 230 V, 2 relay)**

Can be snapped onto DIN rail on the back of the controller.

Wired externally to the desired digital outputs.

These must then be structured with S57 to S68.

e.g. connection for ±Δy outputs in the S-controller with coupling relay 230 V, 2 relays (6DR2804-8B)

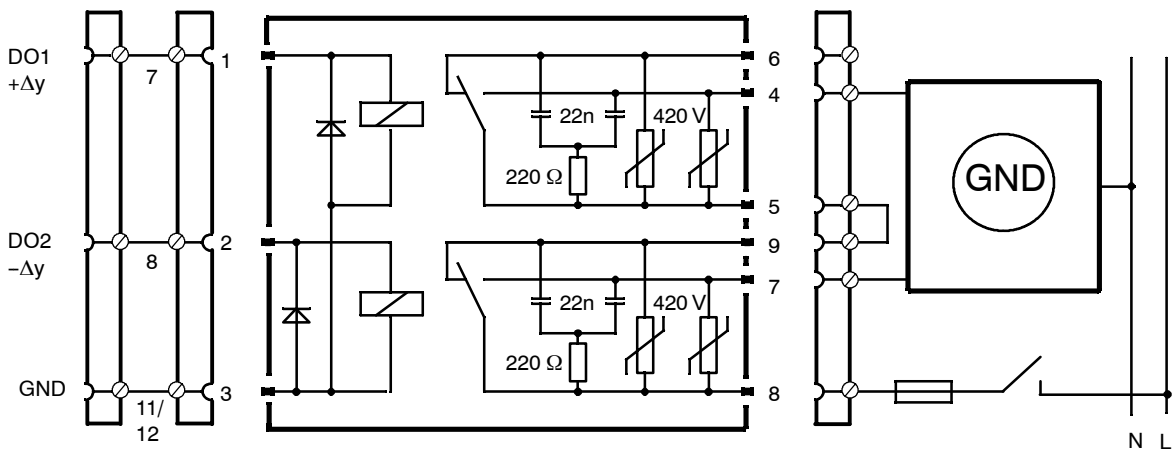

Figure 4-38 Connection of coupling relay 230 V 6DR2804-8B

Contacts in the connection are interlocked!



**CAUTION**

Observe the maximum switching voltage! (For excess resonance in phase shift motors, see “CAUTION” on page 33)

The coupling relay 6DR2804-8B (figure 4-38, page 143) contains 2 relays. The coupling relay 6DR2804-8A contains 4 relays. The terminals 1 to 9 are therefore available double.

AC 250 V  
 8 A  
 1250 VA

DC 250 V  
 8 A  
 30 W at 250 V  
 100 W at 24 V

**4.2.4 Connection of the interface module 6DR2803-8C**

**4.2.4.1 RS 232 point-to-point (END/END)**

Can be inserted in slot 4, set structure switches S84 to S91 for transmission procedure.

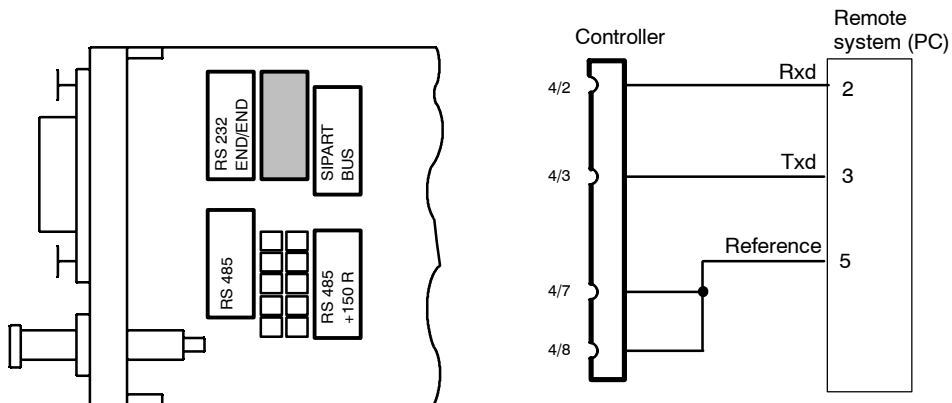

Figure 4-39 Setting on the SES-module 6DR2803-8C with RS 232 point-to-point connection



### 4.2.4.2 RS 485 bus

Can be inserted in slot 4, set structure switches S84 to S91 for transmission procedure.

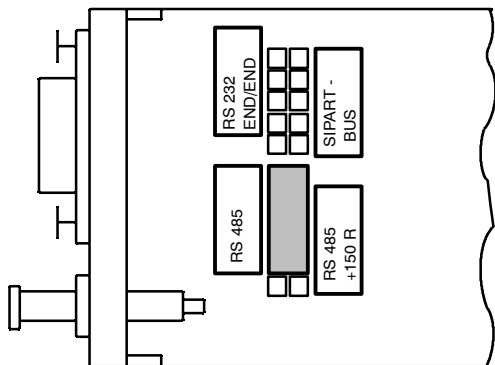

Figure 4-40 Jumper settings SES-module 6DR2803-8C in RS 485 bus

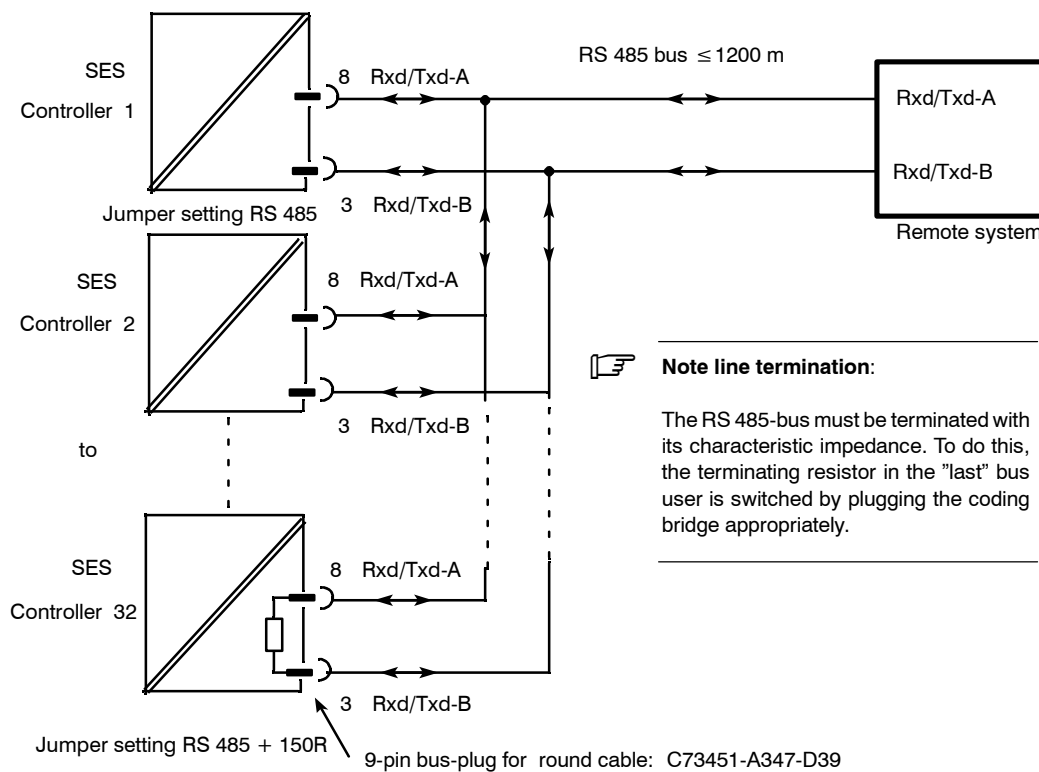

Figure 4-41 RS 485-bus connection

### 4.2.4.3 PROFIBUS-DP, 6DR2803-8P

#### Technical Data

Transmittable signals	RS 485, PROFIBUS-DP-protocol
Transmittable data	Operating state, process variables, parameters and structure switches
Transmission procedure PROFIBUS-/-DP-protocol.	According to DIN 19245, Part 1 and Part 3 (EN 50 170)
Transmission speed	9.6 kbit/s to 1.5 Mbit/s
Station number	0 to 125 (note software version)
Time monitoring of the data communi- cation	Can be structured on the controller in connection with DP watchdog
Electrical isolation between Rxd/Txd-P/-N and the controller	50 V UC common mode voltage
Test voltage	500 V AC
Repeater-control signal CNTR-P	TTL-level with 1 TTL load
Supply voltage VP (5 V)	5 V $-0.4$ V/+0.2 V; short-circuit-proof
Line lengths, per segment at 1.5 MBit/s	200 m; for other data see manual "ET 200 Distribu- ted I/O System", order no. 6ES5 998-3ES22.

● **Connecting the interface PROFIBUS-DP, 6DR2803-8P**

**Connection**

Can be inserted in slot 4, set structure switches S84 to S91 for transmission procedure.

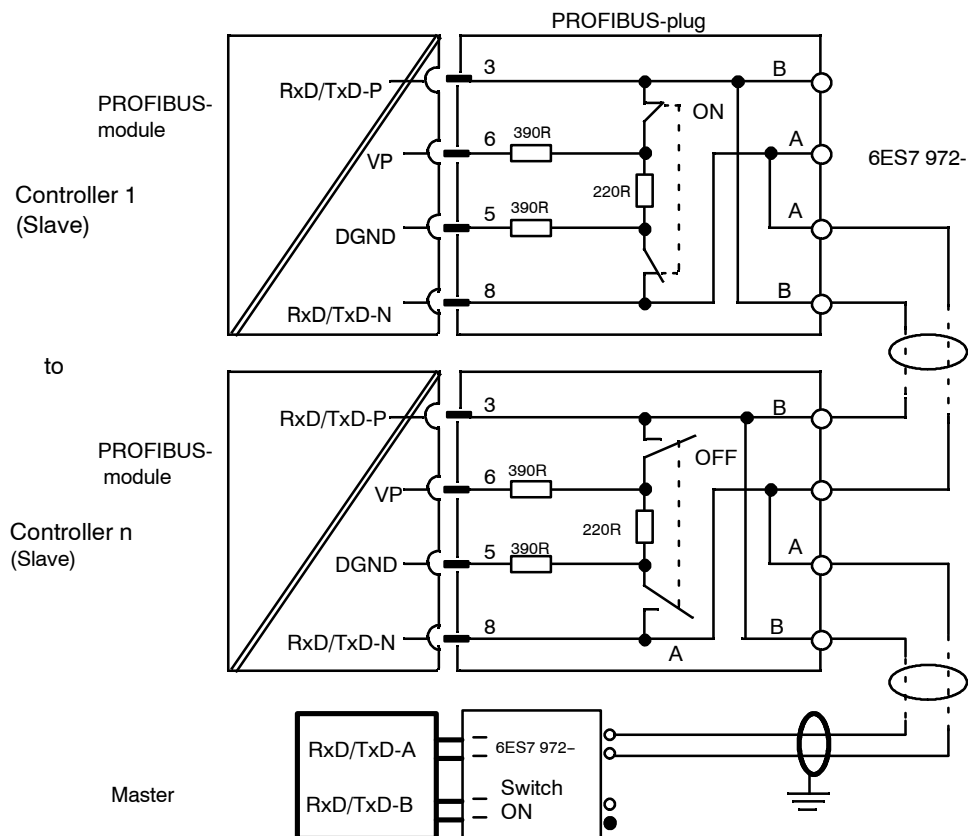

n max. number of controllers, dependent on master, max. 122

Figure 4-42 Block diagram SIPART DR21 via PROFIBUS-DP and bus plug to master



**NOTE line termination:**

The RS 485-bus must be terminated with a characteristic impedance. To do this, the switch in the bus connector must be switched "ON" in the "first" and "last" bus users. The switch may not be "ON" in any of the other bus users. A detailed description and notes on cable laying and bus cable laying can be found in the manual "ET 200 Distributed I/O System" order number 6ES5 998-3ES22.



## 5 Operation

### 5.1 General

- **Operating modes**

The SIPART DR21 is operated exclusively and fully with the operating keys on the front module. The function of the operating panel can be switched between three main levels:

**Process operation mode**      The process values x, w, y and the controller status are displayed, the process operation mode can be controlled by the operating keys.

**Selection level**      Here the list is selected which can be changed or activated in the configuration mode. These are the following lists:

<b>onPA</b>	Online parameters
<b>(AdAP)</b>	Start adaptation
<b>oFPA</b>	Offline parameters
<b>StrS</b>	Structure switches
<b>(CAE3)</b>	Set UNI-module
<b>APSt</b>	all preset

The lists for onPA, oFPA, StrS and APST are always displayed in the selection mode.

The lists for AdAP and CAE3 only appear in the display when they have been selected by structure switches.

**Configuration modes**      Settings are made in the selected list or functions are activated.

Some of the keys and displays on the front module are assigned different control and display functions when the operating mode is changed. See the description of the respective main level for details.

- **Operating locks**

Operation of the controller or access to the selection or configuration modes can be locked by digital signals. The following blocking steps are possible:

**bLb**      *Blocking, Operation*

The complete operation of the controller is blocked. Exception: Switching over the w/x digital display. "bLb" appears in the display on pressing the operating keys.

**bLS**      *Blocking, Structuring*

Blocking the lists **AdAP**, **oFPA**, **StrS**, **CAE3** and **APSt**.

Only the list for onPA is accessible. "bLS" appears in the display when the blocked mode is called

**bLPS**      *Blocking, Parameterization and Structuring*

The complete selection and configuration mode is blocked. The process operation mode is free. "bLPS" appears in the display when the blocked mode is called

- **Behavior of the controller in the factory setting**

SIPART DR21 operates as a fixed value controller in the factory setting. For safety reasons the online parameters, “proportional action factor  $K_p$ ” and the “integral action time  $T_n$ ” are preset to uncritical values.

**It is absolutely essential that these parameters be set to suit the requirements of your controlled system.**

## 5.2 Process operation mode

- **Control elements**

See page 5 for the control and display elements.

The operation of the SIPART DR21 in process mode requires no detailed explanation due to the design and color scheme of the operating panel, the control elements and the labeling.

- **Actual value**

The red vertical LED bargraph (1) and – with the red x LED (5) – of the four-digit digital display (3) lit steadily indicate the actual value.

- **Setpoint**

The green vertical LED bargraph (2) and – with the green w LED (4) – of the four-digit digital display (3) lit steadily indicate the setpoint. The green Internal/External key (16) switches between the internal and external setpoint. The internal setpoint is set with the green  $\pm \Delta$  w adjusting keys (14), (15). The green internal LED (17) signals operation with the internal setpoint,  $\bar{C}$  LED (18) also lights green when there is no CB control signal.

However, a change in the setpoint setting is only possible when the green LEDs (4 and 17) signal that the four-digit display shows the setpoint and Internal operation is active.

- **Manipulated variable**

In the y display (9) the manipulated variable y or, according to the position of the structure switch S54, the position feedback  $y_R$  or split range  $y_1/y_2$  is always displayed independently of the variable output at the analog output AO.

The yellow H/A-key (11) is used to switch between manual and automatic operation. The yellow manual LED (12) signals by lighting steadily or flashing that manual operation has been activated. Lighting up of the yellow y external LED (13) signals an external intervention in the manipulated variable, i.e. a tracking (DDC), safety or blocking operation. The manipulated variable generally displayed in the y digital display (9) can be adjusted with the yellow  $\pm \Delta y$  keys (7), (8) in manual operation. The  $\pm \Delta y$  LEDs (10) indicate the output of the positioning increments in all operating modes of the S-controller.

The alarm LEDs (20) and signal exceeding or dropping below the limit values.

The adaptation LED (19) signals the progress of the parameter optimization during the adaptation process by lighting steadily or flashing.

- **Adaptation**

The adaptation LED (19) signals the active adaptation procedure by flashing.

- **Lamp test**

If the button (6) is kept pressed for longer than 5 s, all LEDs on the front of the controller are driven independently of the respective display until the button is released again. The original display position is restored after checking the lamp function.

- **Display of the software version**

The software for the SIPART DR21 controller will be improved based on new knowledge if required. The respective version of the software is stored in the EPROM with identification and can be called as follows:

- ▶ Run the lamp test with the button (6),
- ▶ Then press the button (16) additionally. On the digital displays (3) and (9) the identification can now be read off for the controller software version.

- **Alarms**

The red alarm LEDs (20) signal exceeding or dropping below the limit values which can be set with the offline parameters A1 to A4. The assignment to the variables to be monitored is made with the structure switches S76, S77, their display with S80.

### 5.3 Selection mode

You enter the selection mode the various configuring menus by pressing the Shift key (6) for longer (approx. 5 s) until "PS" flashes in the y display.

Condition: Digital signal "Blocking Operation" and "Blocking Parameterization, Structuring" are not active.  
bLb = 0 and bLPS = 0

The controller operates in online mode in the selection level, i.e. its last operating mode is retained, the current process variables can be traced on the analog displays (1), (2).

The configuration menus can be selected with the Δ w keys (14), (15). If none of these menus is called with the Enter key (11) within about 20 s (Δ enter the configuring mode), the controller automatically returns to the process operation mode.

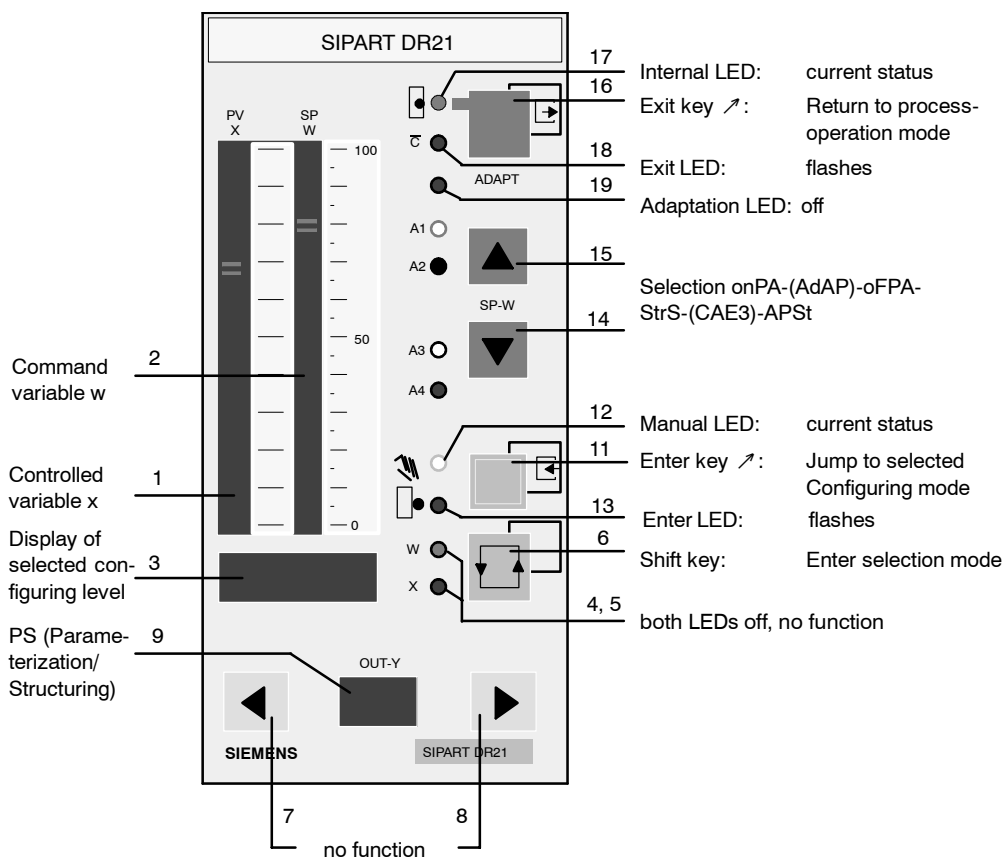
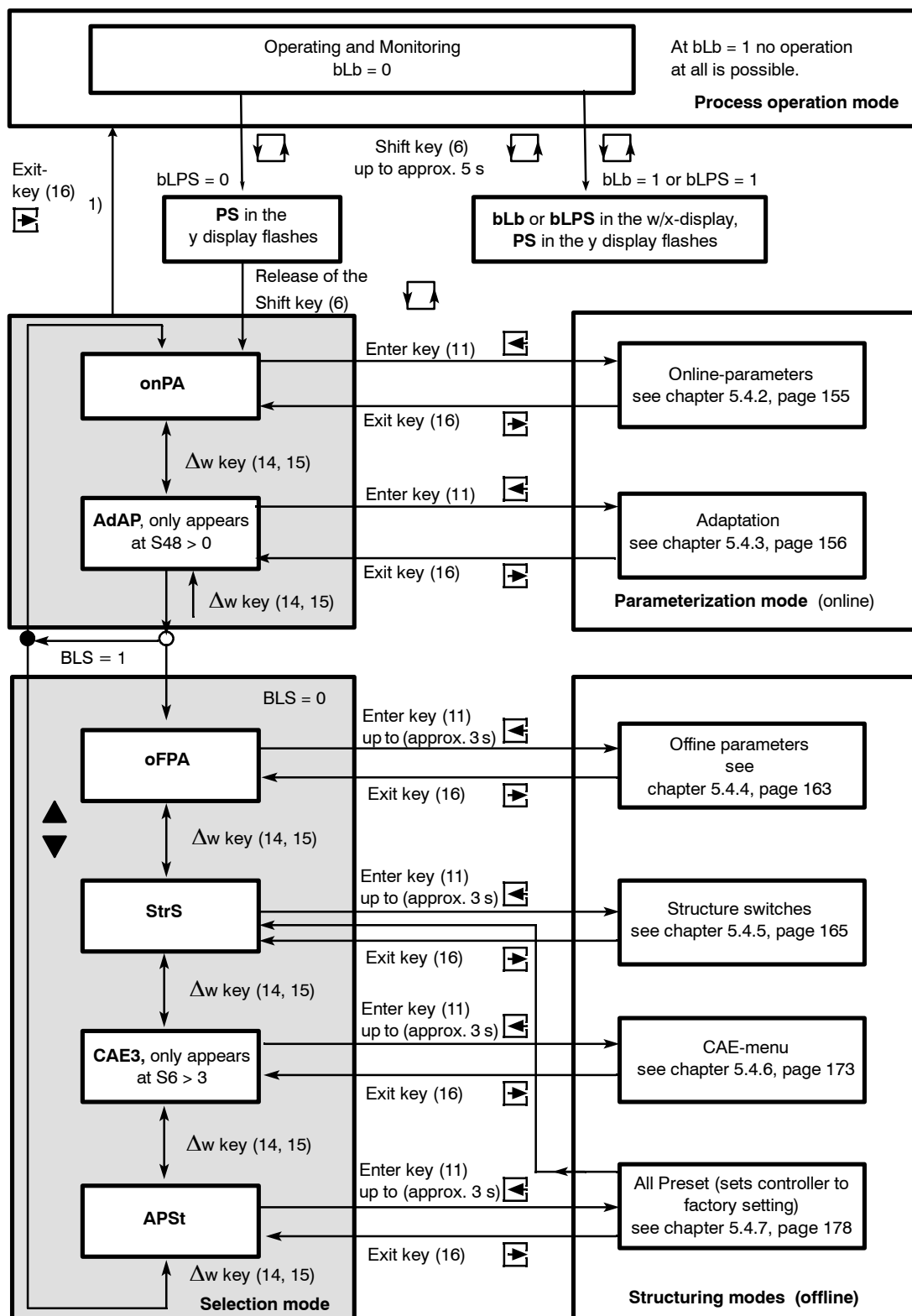

Figure 5-1 Control and display elements in the selection mode





1) automatic return if there is no Enter function to a parameterization- or structuring mode within 20 s.

Figure 5-2 Overview selection mode

## 5.4 Configuration modes

### 5.4.1 General, Online and Offline modes

The settings in the configuration modes onPA and AdAP and the selection in the selection mode (see fig. 5-2, page 153 takes place in online mode, i.e. the controller continues operating in its last mode. The onPA and AdAP modes are entered directly from the selection modes by pressing the Enter key (11). The analog x display (1) and w display (2) still display the process image so that the reaction of the controlled system to parameter changes can be read off directly. The Internal LED (17) and Manual LED (12) and the Alarm LEDs A1 to A4 indicate the current operating state. The Internal/External key (16) becomes the Exit key, the corresponding LED (18) indicates ready to exit, i.e. every time the LED flashes, pressing the Exit key jumps from the selected mode to the next level up in the hierarchy.

The Automatic /Manual key (11) becomes the Enter key, the corresponding y external LED (13) indicates ready to enter, i.e. whenever the LED flashes, pressing the Enter key jumps to the next level down in the hierarchy.

Press the Enter key (11) for 3 s to go from the preselection mode to the offline mode with the oFPA, StrS, APSt and CAE3 menus. The user stays offline when returning (from offline menu) to the preselection mode. When subsequently jumping to another off line mode the three-second time condition is irrelevant. The three-second time condition for entering an offline menu is only valid again after exiting the offline mode by selecting an online mode with the onPA and AdAP menus or exiting the preselection mode. The controller switches into the **absolute manual mode** (offline mode), i.e. the last manipulated variable of the online mode is retained (in K-controllers the last manipulated variable, in S-controllers no positioning increments are output). A change in the manipulated variable using the  $\pm \Delta y$ -keys (7), (8) is not possible, the control signals N (DDC), Si and  $\pm yBL$  are not effective. The analog output, the digital outputs and the alarm LEDs A1 to A4 are held at the last value or status. To identify the offline mode, the analog w display shows a striped pattern and the manual LED (12) lights up. The absolute manual mode is retained when returning to the parameterization preselection mode (online mode) or the process operation mode from the structuring preselection mode with the Exit key (16). This also applies if only automatic operation has been preselected with  $S51 = 1$ . The controller must also be reactivated in the process operation mode for safety reasons by switching to automatic operation.

The analog x display (1) continues to display the controlled variable x during offline mode, the Internal LED (17) the current status. The control elements keys (11), (16) and the LEDs (12), (13), (17), (18) have the same function as in the online configuration modes.

If the control signal  $bLPS = 1$ , parameterization and structuring is blocked, no PS (w/x and y displays) appears when you press the Shift key.

If the control signal  $bLS = 1$ , structuring is blocked. Only onPA and AdAP appear in the selection mode.



#### NOTE

Please note that changed parameters and structure switch settings are only transferred to the failsafe EEPROM after returning to the process operation mode.

### 5.4.2 Configuration mode online-parameters onPA

The parameters for which the effect on the process when they are adjusted must be observed directly are arranged in the parameterization mode onPA. The other parameters are arranged in the structuring mode oFPA. After pressing the Enter key (11) in the onPA configuration mode, the first parameter of table 5-1 Filter time constant tF in the y display (9) appears with its current value in the w/x display (3) the first time the mains is switched on. Otherwise the parameter selected last the last time the onPA mode was exited appears. With the  $\Delta y$  keys (7), (8) the parameters are selected, with keys  $\Delta w$  (14), (15) the value is set. The parameters with a large number range can be adjusted in fast mode.

First select the adjustment direction with one  $\Delta w$  key and then switch on the rapid action by simultaneously pressing the other  $\Delta w$  key.

#### onPA Online Parameter list

parameters	y Num.	w/x display			Unit
	Parameter name	Min.	Max.	Factory setting	
Filter time constant for filter xd (adaptive)	tF	off/1.000	1000	1.000	s
Derivative-action gain Vv	uu	0.100	10.00	5.000	1
Proportional gain factor Kp	cP	0.100	100.0	0.100	1
Integral-action time Tn	tn	1.000	9984	9984	s
Derivative-action time Tv	tv	off/1.000	2992	off	s
Response threshold	AH	0.0	10.0	0.0	%
Operating point	Y0	Auto/0.0	100.0	Auto	%
Output start ( $YA \leq YE$ )	YA	-10.0	110.0	-5.0	%
Output end	YE	-10.0	110.0	105.0	%
y actuating time open/period heating	tP	off/0.100	1000	1.000	s
y actuating time closed/period cooling	tM	off/0.100	1000	1.000	s
Actuating pulse pause	tA <sup>2)</sup>	20	<sup>1)</sup> 600	200	ms
Actuating pulse length	tE <sup>2)</sup>	20	<sup>1)</sup> 600	200	ms
Filter time AI1	t1	off/0.100	1000	1.000	s
Filter time AI2	t2	off/0.100	1000	1.000	s
Filter time AI3	t3	off/0.100	1000	1.000	s
Filter time AI4	t4	off/0.100	1000	1.000	s
Constant c1	c1	-1.999	9.999	0.000	
Constant c2	c2	-1.999	9.999	0.000	
Constant c3	c3	-1.999	9.999	0.000	
Constant c4	c4	-1.999	9.999	1.000	
Constant c5	c5	-1.999	9.999	0.000	
Constant c6	c6	-9.99	9.99	0.00	
Constant c7	c7	+1.000	9.999	1.000	
Display refresh rate	dr	0.100	9.900	1.000	s

<sup>1)</sup> In two-position controller S2 = 1 up to 9980 ms

<sup>2)</sup> In two-position controllers: tA = shortest turn-on pulse and shortest pulse pause in the cooling branch  
tE = shortest turn-on pulse and shortest pulse duration in the heating branch

Table 5-1 Online selection list

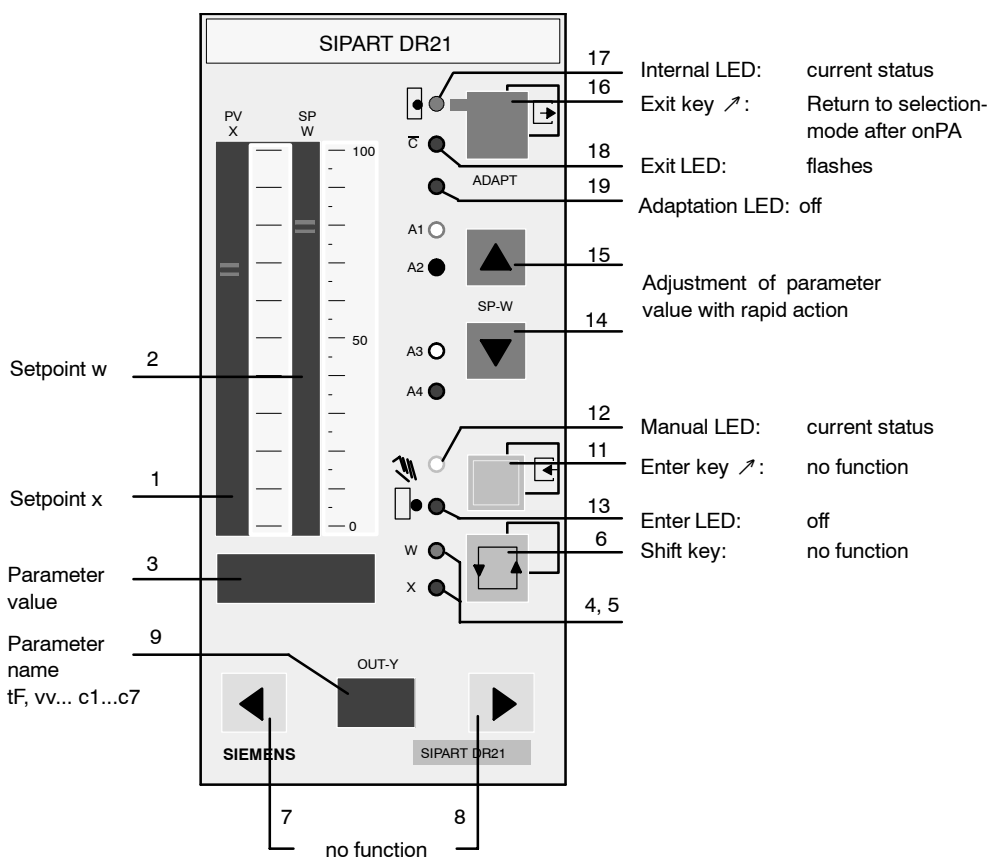

Figure 5-3 Control and display elements in the configuration mode onPA

### 5.4.3 Configuration mode adaptation AdAP

This mode only appears in the selection mode  $S48 > 0$  (with adaptation). The Enter function to the AdAP configuration mode is only possible when the controller is in manual mode. For this the structure switch  $S51$  must be  $\neq 1$  (see structure switch list, table 5-5, page 172). In the parameterization mode AdAP, the controller influences the process online (but in manual operation).

A distinction is made between 4 different states in the AdAP configuration mode

- Pre adaptation,
- During adaptation,
- Aborted adaptation,
- Post adaptation

In pre- and post-adaptation the digital displays and the keys are used for the parameter display and setting as is the case in the parameterization mode and structuring mode onPA or oFPA. The complete process image as described in chapter 5.2, page 150 is displayed during adaptation.

In the case of aborted adaptation the error message flashes in the digital w/xdisplay (3). The error messages are acknowledged with the Enter key (11) (see figure 5-5, page 160).

---

- **Conditions for adaptation**

- The controller must be in a stationary condition, i.e. the controlled variable  $x$  must be constant.
- The system to be adapted must be a system with compensation, i.e. the manipulated variable step in the adaptation must lead to a constant controlled variable  $x$ .
- No adaptation can be performed in stepper controllers with  $S2 = 2$  and firmware version A04 or earlier. Adaptation here is only possible in connection with the external feedback (jumper setting via S19 to  $y_R$ ). As of firmware A05 or higher the change in the manipulated variable required for adaptation is determined from the drive runtime. Accurate setting of the parameters  $t_P$  and  $t_M$  is presumed.
- It is recommended to start the adaptation from the  $y$  value (operating point) usual for this type of control circuit.

- **Pre adaptation**

The controller must be switched to manual (key (11)) before entering the selection mode. The "AdAP" menu can only be selected at  $S48 > 0$ . It is called with the Enter key (11). The adaptation LED (19) is off and indicates readiness for adaptation. First the parameters for the presettings ( $t_U$ ,  $dP_v$ ,  $dY$ ) are displayed. They must be set according to the desired step command. Then the old online parameters appear on the displays (see table 5-1, page 155) with their respective value. This can only be preset in the onPA mode.

---

**NOTICE**

Make sure the set step command causes no damage to the process control system. The control loop is not closed during the adaptation. The adaptation procedure is unsuitable for systems without compensation (systems with integral behaviour).

---

The selection of the parameters is made with the keys (7), (8), the setting of the values with the keys (14), (15). The LED (13) flashes when "Strt" appears in the w/x display (3). Adaptation can now be started with Enter (11).

- **During adaptation**

The adaptation LED (19) flashes indicating that the adaptation is in progress. The process can be monitored over the whole process display. Keys (7), (8), (14) and (15) have no function. The w/x display (3) can be switched over with the key (6) depending on the position of S81. The adaptation can be aborted manually with the key (16).

- **Aborted adaptation**

The current adaptation can be aborted manually or automatically by the error monitor.

The adaptation LED (19) is off indicating readiness for adaptation after error acknowledgement. The Enter LED (13) flashes as a request for error acknowledgement.

Manual abortion can be activated in the event of danger by pressing the Exit key (16). The program then jumps to the selection mode after AdAP. From there you can return to the process operation level by pressing the Exit key (16) again. The controller is in manual operation and the manual manipulated variable can be adjusted.

Automatic abortion is effected by the error monitors (see table 5-3, page 162). The error messages are displayed on the digital w/xdisplay. The error message is acknowledged by pressing the Enter key (11), the configuration mode AdAP is retained, tU is displayed, the presettings can be corrected if necessary. The adaptation is aborted by the signals N (DDC), Si and  $\pm yBL$ . Abortion by the SES control signals  $N_{ES}$  (DDC),  $Si_{ES}$ ,  $\pm yBL_{ES}$  can be prevented by Internal operation.

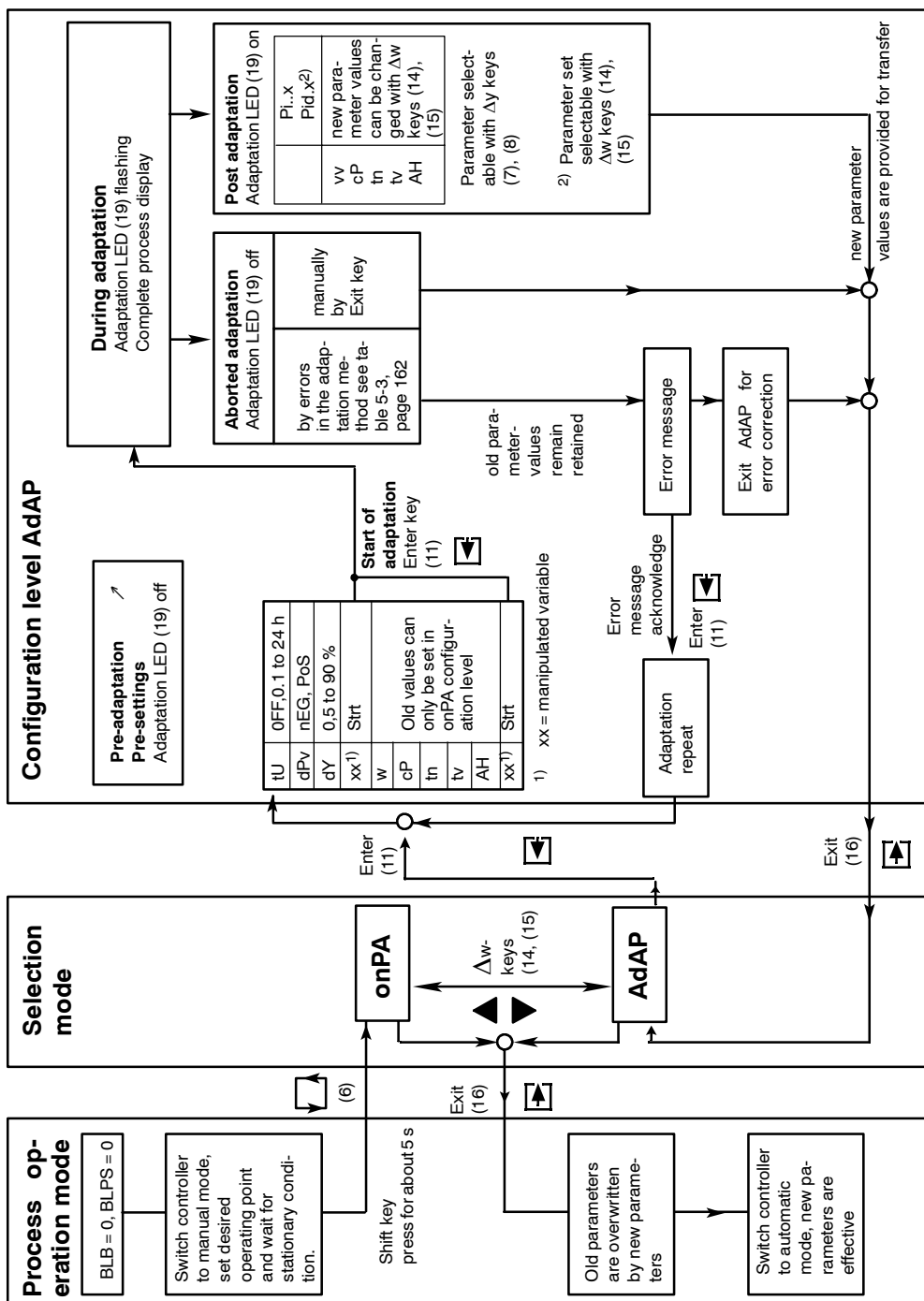

Figure 5-4 Overview configuration level AdAP

● **Post adaptation**

The adaptation LED (19) is on indicating the end of adaptation. PI .x appears in the w/x display. You can switch over to PID.x with the keys (14), (15). These are the two controller designs which have been determined for the new online parameters. The digit x stands for the calculated system order. With the keys (7), (8) the new parameters belonging respectively to the PI or PID controller can be displayed and their values changed with the keys (14), (15).

After pressing the Exit key (16) twice you go to the process operation mode. The previously selected parameter set PI or PID is only entered now and becomes effective in the control process after switching over to automatic operation with key (11). The respective other parameter set is not saved.

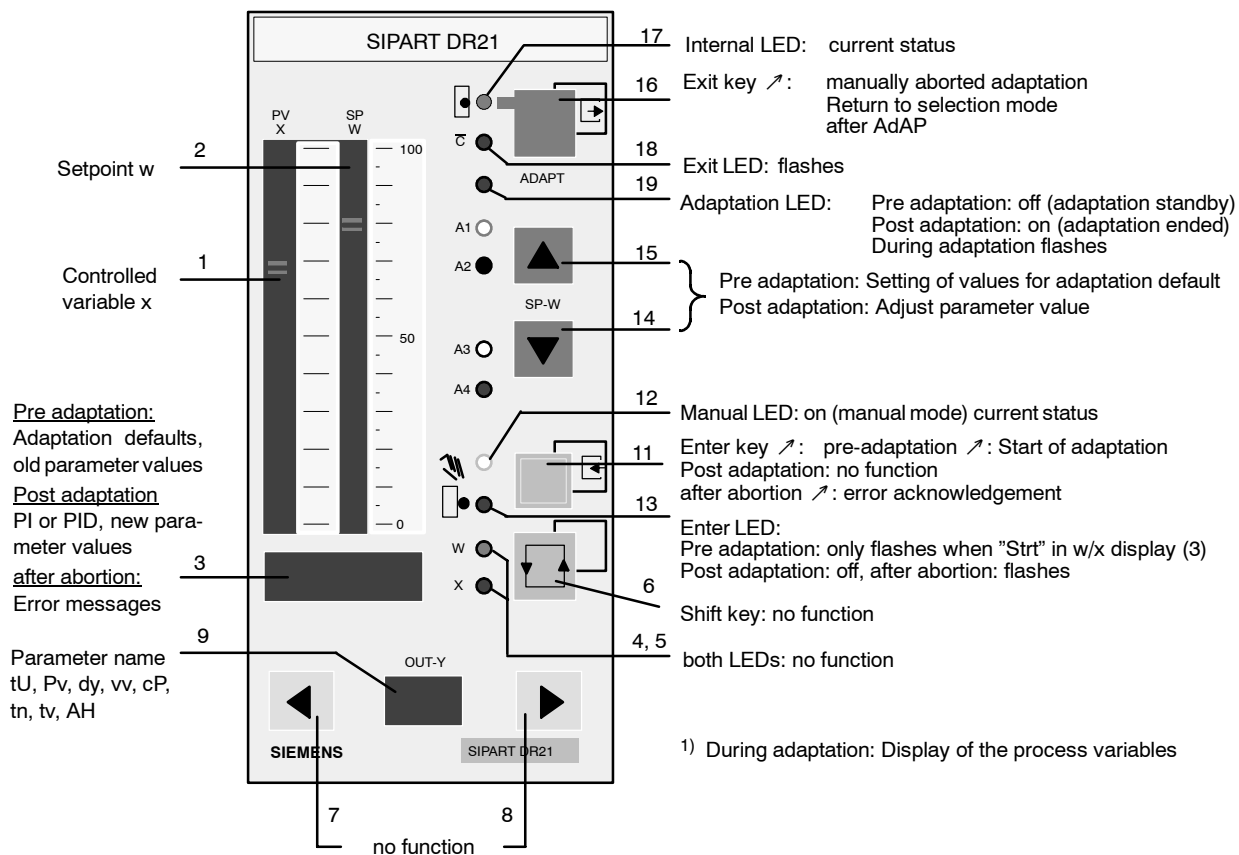

Figure 5-5 Control and display elements in the configuration mode AdAP



**List of start parameters**

Parameters	y display	w/x display			Unit
	Parameter names	Min.	Max.	Factory setting	
Monitoring time Recommendation: "off" (automatic)	tU	off / 0,1	24	off	h
Direction of y step	Pv	nEG	PoS	PoS	-
Amplitude of y step, Recommendation Choose step width so that x rises/falls by about 10%.	dY	0,5	90	0,5	%
Start position for adaptation	y value	Strt			-
Pre adaptation controller parameter	uu	vv value	values		1
	cP	Kp value	not		1
	tn	Tn value	changeable <sup>1)</sup>		s
	tv	Tv value			s
	AH	AH value			%
Start position for adaptation	y value	Strt			-

<sup>1)</sup> Value range see online parameters

Table 5-2 Parameter list AdAP

● **Error messages of the adaptation procedure**

Error messages digital x/w display	Explanation	
StAt	not stable at 10 % tU after Start of adaptation ⇒ wait and restart adaptation	
nody	after expiry of the step command the y step in the S- controller is not yet executed correctly ⇒	Check position feedback and drive of the final control element
y.OFL	y outside the manipulated variable limits $Y_A$ , $Y_E$ (see online parameters) ⇒	$y_{Manual} \pm \Delta y$ too big or too small
PASS	step response in wrong direction within 30 % tU ⇒ Change controller direction of effect (S46) ⇒ control loop undershoot (all pass loop), all-pass loops not defined among loop models	
SMAL	x after 50 % tU still within starting band ⇒ tU selected too small ⇒ y step too small	
n.End	at 67 % tU full scale value not reached yet ⇒ tU selected too small ⇒ loop cannot reach full scale value, e.g. integrally active line ⇒ transient recovery time $t_{95} > 12$ h	
P.oFL	x outside the measuring span 0 to 100 % ⇒	$y_{Manual} \pm \Delta y$ too big or too small
FAST	because of too small a line time constant no adaptation of sufficient quality is possible	(transient recovery time $t_{95} < 5$ s)
ovEr Shot	> 10 % overshoot of the transient function ⇒ adaptation of sufficient quality is possible	
n.ddc	tracking or DCC mode by control signals	⇒
Si	safety operation via the control signals	⇒ cancel mode of operation
yBL	direction-dependent blocking mode via the control signals	⇒

Table 5-3 Adaptation error messages

### 5.4.4 Configuration level offline parameters oFPA

The offline parameters determine basic functions such as display ranges, limit values, safety values and transmission function of the input variables.

After pressing the Enter key (11) in the ofPA configuration mode (approx. 3 s), the first parameter of table 5-4, page 164 dP in the y display (9) appears with its current value in the w/x display (3) the first time the mains is switched on. Otherwise the parameter selected last the last time the ofPA mode was exited appears. With the Δy keys (7), (8) the parameters are selected, with keys Δw keys (14), (15) the value is set. The parameters with a large number range can be adjusted in fast mode.

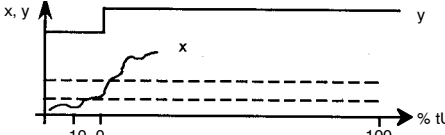
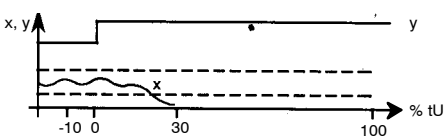
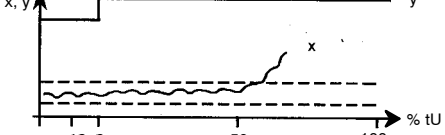
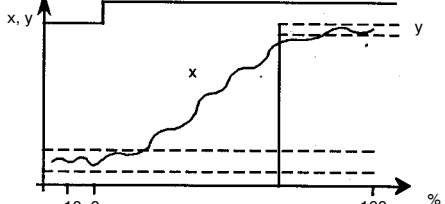
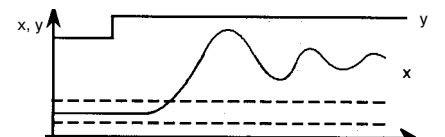
First select the adjustment direction with one Δw key and then switch on the rapid action by simultaneously pressing the other Δ w key. The ofPA display reappears after pressing the Exit key (16) once. From this state you can change to any other offline configuration mode without the 3 s wait necessary for a new entry by tapping the Enter key (11). This applies accordingly for all offline configuration modes.

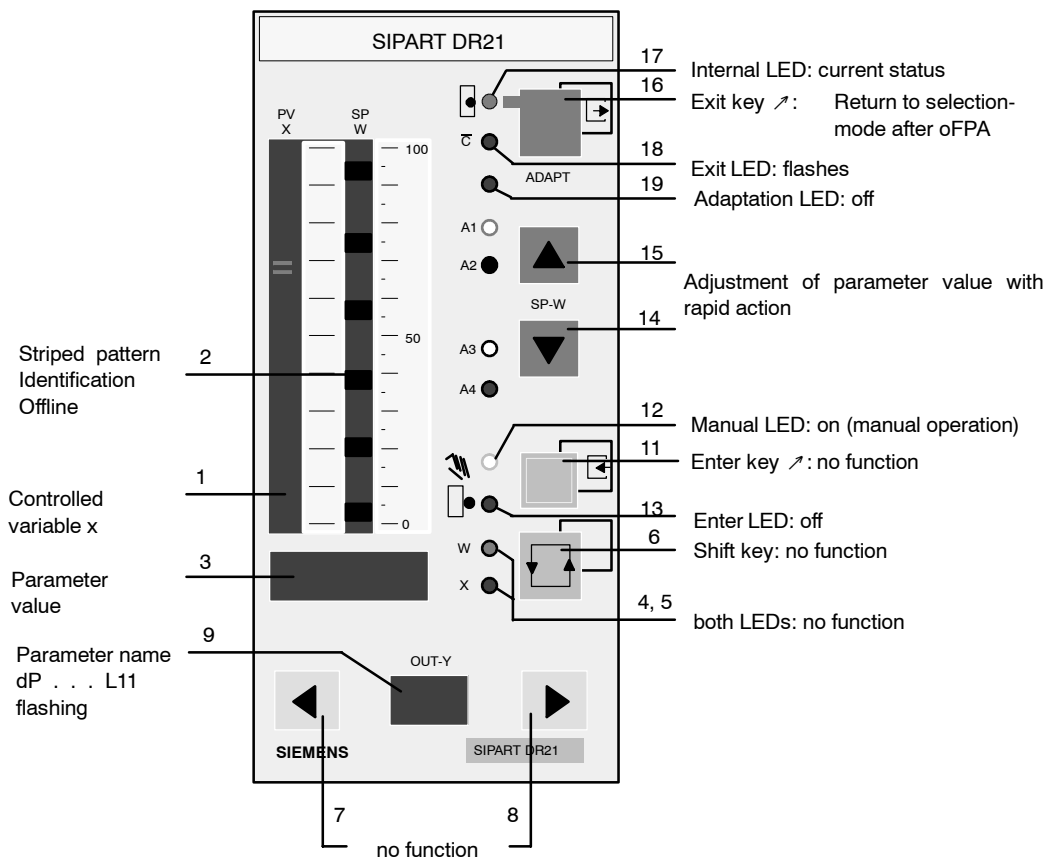

Figure 5-6 Control and display elements in the parameterization mode oFPA

**oFPA Offline parameter list**

Parameter	y display	w / x display			Unit
	Param-names	Min.	Max.	Factory setting	
Decimal point w/x num.	dP	_.----	----	----.-	-
Start of scale	dA	-1999	9999	0.0	
Full scale	dE	-1999	9999	100.0	
Alarm 1	A1	-110% to 110%		5.0	
Alarm 2 (A2 ≤ A1)	A2	from dA, dE		-5.0	
Alarm 3	A3	at S76 / S77 =		5.0	
Alarm 4 (A4 ≤ A3)	A4	0 to 5 and 17		-5.0	
Hysteresis alarms	HA	0.1	10.0	1.0	%
Setpoint start	SA	-10% to 110%		-5.0	
Setpoint end	SE	from dA, dE		105.0	
Safety setpoint	SH			0.0	
Setpoint ramp time	tS	oFF/0.100	9984	oFF	min
Ratio factor start	vA	0.000	9.999	0.000	1
Ratio factor end	vE	0.000	9.999	1.000	1
Safety output variable	YS	-10.0	110.0	0.0	%
Split range left (Y1 ≤ Y2)	Y1	0.0	100.0	50.0	%
Split range right	Y2	0.0	100.0	50.0	%
Output values of the linearizer L-1 (-10%) to L11 (110%) are equidistant input vertex points  (1) Note At S21=5, values standardized to dA to dE.	L-1	-10.0	110.0	-10.0	% (1)
	L0	-10.0	110.0	0.0	% (1)
	L1	-10.0	110.0	10.0	% (1)
	L2	-10.0	110.0	20.0	% (1)
	L3	-10.0	110.0	30.0	% (1)
	L4	-10.0	110.0	40.0	% (1)
	L5	-10.0	110.0	50.0	% (1)
	L6	-10.0	110.0	60.0	% (1)
	L7	-10.0	110.0	70.0	% (1)
	L8	-10.0	110.0	80.0	% (1)
	L9	-10.0	110.0	90.0	% (1)
	L10	-10.0	110.0	100.0	% (1)
L11	-10.0	110.0	110.0	% (1)	
Decimal point <sup>1)</sup>	Pd	_.----	----	----.-	
Start value <sup>1)</sup>	Ad	-1999	9999	0.0	-
Full scale value <sup>1)</sup>	Ed	-1999	9999	100.0	

<sup>1)</sup> as of software version -A9, only in ratio controller (S1 = 3)  
Display range of controlled variable x1 and the weighted commanding process variable w (S81 = 7)

Table 5-4 Offline parameter list

### 5.4.5 Configuration mode structure switch StrS

The structure switches are software switches which determine the function and structure of the controller. They are set in the offline mode.

After pressing the Enter key (11) in the StrS configuration mode (approx. 3 s), the structure switch S1 in the y display (9) appears with its current setting in the w/x- display the first time the mains is switched on. Otherwise structure switch selected last the last time the StrS- mode was exited appears. The switch number is changed with the Δy keys (7), (8). If the adjustment direction is selected with a Δy key, tens steps of the counter can be generated by simultaneously pressing the other Δy key. With the Δw keys (14), (15) the respective switch is set (see table 5-5, page 172).

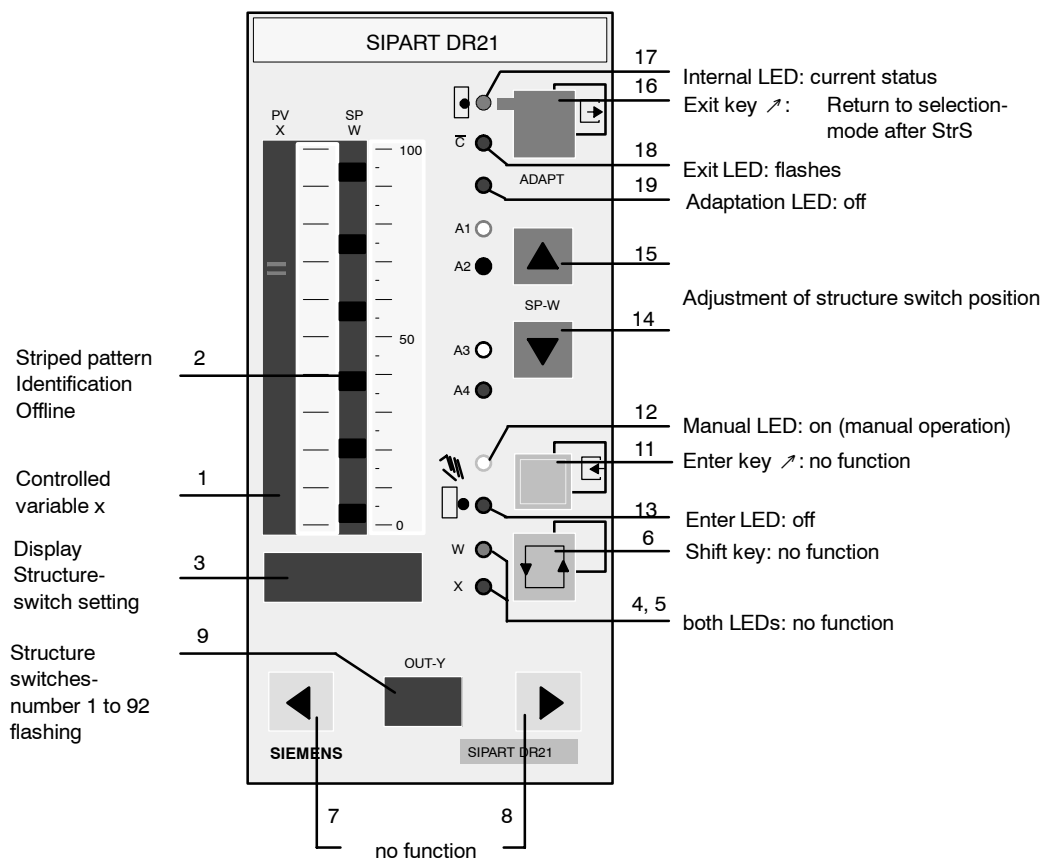

Figure 5-7 Control and display elements in the configuration mode StrS

**StrS – structure switch list**

Structure switch	switch position	Function
Basic settings	S1	<b>Controller type</b> [0] Fixed value/three-component controller/controller with 2 internal setpoints 1 Slave / synchronization / SPC controller 2 DDC controller 3 Ratio controller 4 Control unit / process display 5 Fixed value controller with 1 setpoint for control system coupling (as of software version-A7) 6 Slave controller without internal/external switching for control system coupling (as of software version -A7)
	S2	<b>Output structure</b> [0] K-output 1 S-output two-position controller with 2 outputs heating/cooling *) 2 S-output: three-position step controller for motorized drives, internal feedback *) 3 S-output: three-position step controller for motorized drives, external feedback *)
	S3	<b>Mains frequency suppression</b> [0] 50 Hz 1 60 Hz
Analog inputs	S4	<b>Input signal AI1 and transmitter fault message</b> [0] 0...20 mA without MUF 1 0...20 mA with MUF 2 4...20 mA without MUF 3 4...20 mA with MUF
	S5	<b>Input signal AI2 and transmitter fault message</b> [0] 0...20 mA without MUF 1 0...20 mA with MUF 2 4...20 mA without MUF 3 4...20 mA with MUF
	S6	<b>Input signal AI3 (slot 1) and transmitter fault message</b> [0] 0...20 mA or U,R,P,T without MUF 1 0...20 mA or U,R,P,T with MUF 2 4...20 mA or U without MUF 3 4...20 mA or U with MUF 4 UNI module Min at sensor break without MUF 5 UNI module Max at sensor break without MUF 6 UNI module Min at sensor break with MUF 7 UNI module Max at sensor break with MUF
	S7	<b>Input signal AI4 (slot 2) and transmitter fault message</b> [0] 0...20 mA or U,R,P,T without MUF 1 0...20 mA or U,R,P,T with MUF 2 4...20 mA or U without MUF 3 4...20 mA or U with MUF
	S8	<b>Input signal AI3 (slot 1) with UNI-module (only active at S6=4/5/6/7)</b> [0] mV (linear), with measuring range plug U or I (no active sensor break monitoring) 1 Thermocouple with internal reference point 2 Thermocouple with external reference point 3 PT100 4-wire connection incl. supply lines 4 PT100 3-wire connection incl. supply lines 5 PT100 2-wire connection incl. supply lines 6 Resistance potentiometer with $R < 600 \Omega$ 7 Resistance potentiometer with $600 \Omega \leq R < 2.8 \text{ k}\Omega$

\*) see chapter 6.3 "Adaptation of the S-controller to the actuating drive", page 183

Structure switch	switch position	Function																																									
Analog inputs	S9	<b>Thermocouple type AI3 (slot 1) with UNI-module (only active at S8=1/2)</b> [0] Type L 1 Type J 2 Type K 3 Type S 4 Type B 5 Type R 6 Type E 7 Type N 8 Type T 9 Type U 10 any type (without linearization)																																									
	S10	<b>Temperature unit AI3 (slot 1) with UNI-module (only active at S8=1/2/3/4/5)</b> [0] Degrees Celsius 1 Degrees Fahrenheit 2 Kelvin																																									
	S11 S12 S13 S14	<b>Root extraction AI1 to AI4</b> <table border="1"> <thead> <tr> <th></th> <th>no</th> <th>yes</th> </tr> </thead> <tbody> <tr> <td>AI1</td> <td>[0]</td> <td>1</td> </tr> <tr> <td>AI2</td> <td>[0]</td> <td>1</td> </tr> <tr> <td>AI3</td> <td>[0]</td> <td>1</td> </tr> <tr> <td>AI4</td> <td>[0]</td> <td>1</td> </tr> </tbody> </table>		no	yes	AI1	[0]	1	AI2	[0]	1	AI3	[0]	1	AI4	[0]	1																										
		no	yes																																								
	AI1	[0]	1																																								
AI2	[0]	1																																									
AI3	[0]	1																																									
AI4	[0]	1																																									
S15 S16 S17 S18 S19 S20	<b>Assignment of x1, x2, x3, yN, yR, z from AI1A to AI4A</b> <table border="1"> <thead> <tr> <th></th> <th>0 %</th> <th>AI1A</th> <th>AI2A</th> <th>AI3A</th> <th>AI4A</th> </tr> </thead> <tbody> <tr> <td>x1</td> <td>0</td> <td>[1]</td> <td>2</td> <td>3</td> <td>4</td> </tr> <tr> <td>x2</td> <td>0</td> <td>1</td> <td>[2]</td> <td>3</td> <td>4</td> </tr> <tr> <td>x3/we</td> <td>0</td> <td>1</td> <td>2</td> <td>[3]</td> <td>4</td> </tr> <tr> <td>yN</td> <td>0</td> <td>1</td> <td>2</td> <td>3</td> <td>[4]</td> </tr> <tr> <td>yR</td> <td>[0]</td> <td>1</td> <td>2</td> <td>3</td> <td>4</td> </tr> <tr> <td>z</td> <td>[0]</td> <td>1</td> <td>2</td> <td>3</td> <td>4</td> </tr> </tbody> </table>		0 %	AI1A	AI2A	AI3A	AI4A	x1	0	[1]	2	3	4	x2	0	1	[2]	3	4	x3/we	0	1	2	[3]	4	yN	0	1	2	3	[4]	yR	[0]	1	2	3	4	z	[0]	1	2	3	4
	0 %	AI1A	AI2A	AI3A	AI4A																																						
x1	0	[1]	2	3	4																																						
x2	0	1	[2]	3	4																																						
x3/we	0	1	2	[3]	4																																						
yN	0	1	2	3	[4]																																						
yR	[0]	1	2	3	4																																						
z	[0]	1	2	3	4																																						
Analog inputs	S21	<b>Assignment of the linearizer (see ofPA) open</b> [0] none 1 AI1 2 AI2 3 AI3 4 AI4 5 x1																																									
Slot 3	S22	<b>Assignment slot 3</b> [0] not used 1 4 DO / 2 DI (DO3 – DO6 / DI3, DI4) 4 DO / 1 DI (DO3 – DO6 / DI3, DI4=0) 2 5 DI (DI3 – DI7) 3 2 relays (DO3, DO4)																																									

Structure switch	switch position	Function																																																																																																																																																									
Digital inputs		<b>Assignment of the control signals to digital inputs</b>																																																																																																																																																									
		<table border="1"> <thead> <tr> <th></th> <th>Low</th> <th colspan="2">Stand. contr.</th> <th colspan="7">Slot 3</th> </tr> <tr> <th></th> <th></th> <th>DI1</th> <th>DI2</th> <th>DI3</th> <th>DI4</th> <th>DI5</th> <th>DI6</th> <th>DI7</th> <th>High</th> </tr> </thead> <tbody> <tr> <td>S23</td> <td>CB</td> <td>0</td> <td>1</td> <td>2</td> <td>3</td> <td>4</td> <td>5</td> <td>6</td> <td>7</td> <td>[8]</td> </tr> <tr> <td>S24</td> <td>He</td> <td>[0]</td> <td>1</td> <td>2</td> <td>3</td> <td>4</td> <td>5</td> <td>6</td> <td>7</td> <td>-</td> </tr> <tr> <td>S25</td> <td>N</td> <td>0</td> <td>[1]</td> <td>2</td> <td>3</td> <td>4</td> <td>5</td> <td>6</td> <td>7</td> <td>-</td> </tr> <tr> <td>S26</td> <td>Si</td> <td>0</td> <td>1</td> <td>[2]</td> <td>3</td> <td>4</td> <td>5</td> <td>6</td> <td>7</td> <td>-</td> </tr> <tr> <td>S27</td> <td>P</td> <td>[0]</td> <td>1</td> <td>2</td> <td>3</td> <td>4</td> <td>5</td> <td>6</td> <td>7</td> <td>8</td> </tr> <tr> <td>S28</td> <td>tS</td> <td>[0]</td> <td>1</td> <td>2</td> <td>3</td> <td>4</td> <td>5</td> <td>6</td> <td>7</td> <td>-</td> </tr> <tr> <td>S29</td> <td>+yBL</td> <td>[0]</td> <td>1</td> <td>2</td> <td>3</td> <td>4</td> <td>5</td> <td>6</td> <td>7</td> <td>-</td> </tr> <tr> <td>S30</td> <td>-yBL</td> <td>[0]</td> <td>1</td> <td>2</td> <td>3</td> <td>4</td> <td>5</td> <td>6</td> <td>7</td> <td>-</td> </tr> <tr> <td>S31</td> <td>bLb</td> <td>[0]</td> <td>1</td> <td>2</td> <td>3</td> <td>4</td> <td>5</td> <td>6</td> <td>7</td> <td>-</td> </tr> <tr> <td>S32</td> <td>bLS</td> <td>[0]</td> <td>1</td> <td>2</td> <td>3</td> <td>4</td> <td>5</td> <td>6</td> <td>7</td> <td>-</td> </tr> <tr> <td>S33</td> <td>bLPS</td> <td>[0]</td> <td>1</td> <td>2</td> <td>3</td> <td>4</td> <td>5</td> <td>6</td> <td>7</td> <td>-</td> </tr> <tr> <td>S92</td> <td>tSH</td> <td>[0]</td> <td>1</td> <td>2</td> <td>3</td> <td>4</td> <td>5</td> <td>6</td> <td>7</td> <td>*)</td> </tr> </tbody> </table>		Low	Stand. contr.		Slot 3									DI1	DI2	DI3	DI4	DI5	DI6	DI7	High	S23	CB	0	1	2	3	4	5	6	7	[8]	S24	He	[0]	1	2	3	4	5	6	7	-	S25	N	0	[1]	2	3	4	5	6	7	-	S26	Si	0	1	[2]	3	4	5	6	7	-	S27	P	[0]	1	2	3	4	5	6	7	8	S28	tS	[0]	1	2	3	4	5	6	7	-	S29	+yBL	[0]	1	2	3	4	5	6	7	-	S30	-yBL	[0]	1	2	3	4	5	6	7	-	S31	bLb	[0]	1	2	3	4	5	6	7	-	S32	bLS	[0]	1	2	3	4	5	6	7	-	S33	bLPS	[0]	1	2	3	4	5	6	7	-	S92	tSH	[0]	1	2	3	4	5	6	7	*)
		Low	Stand. contr.		Slot 3																																																																																																																																																						
			DI1	DI2	DI3	DI4	DI5	DI6	DI7	High																																																																																																																																																	
	S23	CB	0	1	2	3	4	5	6	7	[8]																																																																																																																																																
	S24	He	[0]	1	2	3	4	5	6	7	-																																																																																																																																																
	S25	N	0	[1]	2	3	4	5	6	7	-																																																																																																																																																
	S26	Si	0	1	[2]	3	4	5	6	7	-																																																																																																																																																
	S27	P	[0]	1	2	3	4	5	6	7	8																																																																																																																																																
	S28	tS	[0]	1	2	3	4	5	6	7	-																																																																																																																																																
	S29	+yBL	[0]	1	2	3	4	5	6	7	-																																																																																																																																																
	S30	-yBL	[0]	1	2	3	4	5	6	7	-																																																																																																																																																
	S31	bLb	[0]	1	2	3	4	5	6	7	-																																																																																																																																																
	S32	bLS	[0]	1	2	3	4	5	6	7	-																																																																																																																																																
S33	bLPS	[0]	1	2	3	4	5	6	7	-																																																																																																																																																	
S92	tSH	[0]	1	2	3	4	5	6	7	*)																																																																																																																																																	
		* as of software version -B5																																																																																																																																																									
Digital inputs		<b>Direction of effect of the DIs on assigned control signals</b>																																																																																																																																																									
		<table border="1"> <thead> <tr> <th></th> <th>24 V = High</th> <th>0 V = High</th> </tr> </thead> <tbody> <tr> <td>S34</td> <td>CB</td> <td>[0]</td> <td>1</td> </tr> <tr> <td>S35</td> <td>He</td> <td>[0]</td> <td>1</td> </tr> <tr> <td>S36</td> <td>N</td> <td>[0]</td> <td>1</td> </tr> <tr> <td>S37</td> <td>Si</td> <td>[0]</td> <td>1</td> </tr> <tr> <td>S38</td> <td>P</td> <td>[0]</td> <td>1</td> </tr> <tr> <td>S39</td> <td>tS/tSH</td> <td>[0]</td> <td>1</td> </tr> <tr> <td>S40</td> <td>+/-yBL</td> <td>[0]</td> <td>1</td> </tr> </tbody> </table>		24 V = High	0 V = High	S34	CB	[0]	1	S35	He	[0]	1	S36	N	[0]	1	S37	Si	[0]	1	S38	P	[0]	1	S39	tS/tSH	[0]	1	S40	+/-yBL	[0]	1																																																																																																																										
		24 V = High	0 V = High																																																																																																																																																								
	S34	CB	[0]	1																																																																																																																																																							
	S35	He	[0]	1																																																																																																																																																							
	S36	N	[0]	1																																																																																																																																																							
	S37	Si	[0]	1																																																																																																																																																							
S38	P	[0]	1																																																																																																																																																								
S39	tS/tSH	[0]	1																																																																																																																																																								
S40	+/-yBL	[0]	1																																																																																																																																																								
S41	[0] 1 2	<b>Control signal CB</b> static without acknowledgement static with acknowledgement dynamic as pulse (flip- flop effect)																																																																																																																																																									
setpoint switching	S42	[0] 1 2	<b>Blocking of internal/external setpoint switching</b> internal only external only no blocking																																																																																																																																																								
	S43	[0] 1	<b>x tracking at H or N (DDC) or Si</b> no yes																																																																																																																																																								
	S44	[0] 1	<b>setpoint at CB failure</b> last wi safety setpoint SH																																																																																																																																																								
	S45	[0] 1	<b>Tracking wi to the active setpoint w</b> or tracking of wvi to the active nominal ratio wv yes no																																																																																																																																																								
Control algorithm	S46	[0] 1	<b>Direction of control action to xd ( w – x)</b> normal (Kp > 0) reversed (Kp < 0)																																																																																																																																																								
	S47	[0] 1 2 3 4	<b>D-element connection</b> xd x x1 z direction of control action against x z direction of control action with x																																																																																																																																																								



Structure switch		switch position	Function		
Control algorithm	S48	[0]	<b>Adaptation selection</b> no adaptation		
		1	control behavior without overshoot		
		2	control behavior with transient recovery after the amount optimum		
output switching	S49	[0]	<b>Priority N (DDC) or H</b> N (DDC)		
		1	H		
	S50	[0]	<b>Manual mode with transmitter fault</b> no switching (display only)		
		1	manual operation starting with last y		
		2	manual operation starting with ys		
	S51		<b>switching manual / automatic via</b>		
	[0]	Manual key Hi	Control signal He	Locking HeES	
	1	yes	yes / static	with	
	2	no	yes / static	with	
	3	no switching manual operation			
	4	yes	yes / dynamic	with	
		yes	yes / dynamic	without	
	S52	[0]	<b>ly switch-off in DDC or tracking mode (only K-controllers)</b> without		
		1	with		
	S53	[0]	<b>Output variable limit YA / YE</b> only active in automatic operation		
		1	active in all operating modes		
y display	S54	[0]	<b>Output variable display</b> controller output y		
		1	position feedback y <sub>R</sub>		
		2	Split range y <sub>1</sub> /y <sub>2</sub>		
		3	no display		
	S55	[0]	<b>Direction of control action of the output variable display yAn</b> normal: yAn = y		
		1	reversed: yAn = 100% - y		
Switching analog output	S56	[0]	y	0 to 20 mA	
		1	y	4 to 20 mA	
		2	w	0 to 20 mA	
		3	w	4 to 20 mA	
		4	x	0 to 20 mA	
		5	x	4 to 20 mA	
		6	x1	0 to 20 mA	
		7	x1	4 to 20 mA	
		8	xd + 50%	0 to 20 mA	
		9	xd + 50%	4 to 20 mA	
		10	y1	0 to 20 mA	as of version -B2
		11	y1	4 to 20 mA	as of version -B2
		12	y2	0 to 20 mA	as of version -B2
		13	y2	4 to 20 mA	as of version -B2
		14	1-y1	0 to 20 mA	as of version -B2
		15	1-y1	4 to 20 mA	as of version -B2
		16	1-y2	0 to 20 mA	as of version -B2
17	1-y2	4 to 20 mA	as of version -B2		

Structure switch	switch position	Function																																																																																																																																
Digital outputs	S57	<p><b>Assignment +/-Δy</b></p> <table border="1"> <thead> <tr> <th></th> <th>DO1</th> <th>DO2</th> <th>DO7 (relay)</th> <th>DO8 (relay)</th> </tr> </thead> <tbody> <tr> <td>[0]</td> <td>-</td> <td>-</td> <td>+Δy</td> <td>-Δy</td> </tr> <tr> <td>1</td> <td>+Δy</td> <td>-Δy</td> <td>-</td> <td>-</td> </tr> <tr> <td>2</td> <td>-</td> <td>-Δy</td> <td>+Δy</td> <td>-</td> </tr> <tr> <td>3</td> <td>+Δy</td> <td>-</td> <td>-</td> <td>-Δy</td> </tr> </tbody> </table> <p>Note: S57 has priority over S58 to S68</p>		DO1	DO2	DO7 (relay)	DO8 (relay)	[0]	-	-	+Δy	-Δy	1	+Δy	-Δy	-	-	2	-	-Δy	+Δy	-	3	+Δy	-	-	-Δy																																																																																																							
		DO1	DO2	DO7 (relay)	DO8 (relay)																																																																																																																													
	[0]	-	-	+Δy	-Δy																																																																																																																													
	1	+Δy	-Δy	-	-																																																																																																																													
	2	-	-Δy	+Δy	-																																																																																																																													
	3	+Δy	-	-	-Δy																																																																																																																													
	S58	<p><b>Assignment of message signals to digital outputs</b></p> <table border="1"> <thead> <tr> <th rowspan="2"></th> <th rowspan="2">none</th> <th colspan="2">Stand. contr.</th> <th colspan="4">Slot 3</th> <th colspan="2">Standard controller</th> </tr> <tr> <th>DO1</th> <th>DO2</th> <th>DO3</th> <th>DO4</th> <th>DO5</th> <th>DO6</th> <th>DO7 (relay)</th> <th>DO8 (relay)</th> </tr> </thead> <tbody> <tr> <td><math>\overline{RB}</math></td> <td>[0]</td> <td>1</td> <td>2</td> <td>3</td> <td>4</td> <td>5</td> <td>6</td> <td>7</td> <td>8</td> </tr> <tr> <td><math>\overline{RC}</math></td> <td>[0]</td> <td>1</td> <td>2</td> <td>3</td> <td>4</td> <td>5</td> <td>6</td> <td>7</td> <td>8</td> </tr> <tr> <td>H</td> <td>[0]</td> <td>1</td> <td>2</td> <td>3</td> <td>4</td> <td>5</td> <td>6</td> <td>7</td> <td>8</td> </tr> <tr> <td>Nw</td> <td>[0]</td> <td>1</td> <td>2</td> <td>3</td> <td>4</td> <td>5</td> <td>6</td> <td>7</td> <td>8</td> </tr> <tr> <td>A1</td> <td>0</td> <td>[1]</td> <td>2</td> <td>3</td> <td>4</td> <td>5</td> <td>6</td> <td>7</td> <td>8</td> </tr> <tr> <td>A2</td> <td>0</td> <td>1</td> <td>[2]</td> <td>3</td> <td>4</td> <td>5</td> <td>6</td> <td>7</td> <td>8</td> </tr> <tr> <td>A3</td> <td>[0]</td> <td>1</td> <td>2</td> <td>3</td> <td>4</td> <td>5</td> <td>6</td> <td>7</td> <td>8</td> </tr> <tr> <td>A4</td> <td>[0]</td> <td>1</td> <td>2</td> <td>3</td> <td>4</td> <td>5</td> <td>6</td> <td>7</td> <td>8</td> </tr> <tr> <td>MUF</td> <td>[0]</td> <td>1</td> <td>2</td> <td>3</td> <td>4</td> <td>5</td> <td>6</td> <td>7</td> <td>8</td> </tr> <tr> <td>+Δw</td> <td>[0]</td> <td>1</td> <td>2</td> <td>3</td> <td>4</td> <td>5</td> <td>6</td> <td>7</td> <td>8</td> </tr> <tr> <td>-Δw</td> <td>[0]</td> <td>1</td> <td>2</td> <td>3</td> <td>4</td> <td>5</td> <td>6</td> <td>7</td> <td>8</td> </tr> </tbody> </table> <p>Notes:</p> <ul style="list-style-type: none"> <li>If DO1/2 or DO7/8 are occupied by S57 with +/-Δy, no double assignment is possible!</li> <li>S67 and S68 only active at S1=4 (control unit/process display).</li> </ul>		none	Stand. contr.		Slot 3				Standard controller		DO1	DO2	DO3	DO4	DO5	DO6	DO7 (relay)	DO8 (relay)	$\overline{RB}$	[0]	1	2	3	4	5	6	7	8	$\overline{RC}$	[0]	1	2	3	4	5	6	7	8	H	[0]	1	2	3	4	5	6	7	8	Nw	[0]	1	2	3	4	5	6	7	8	A1	0	[1]	2	3	4	5	6	7	8	A2	0	1	[2]	3	4	5	6	7	8	A3	[0]	1	2	3	4	5	6	7	8	A4	[0]	1	2	3	4	5	6	7	8	MUF	[0]	1	2	3	4	5	6	7	8	+Δw	[0]	1	2	3	4	5	6	7	8	-Δw	[0]	1	2	3	4	5	6	7	8
					none	Stand. contr.		Slot 3				Standard controller																																																																																																																						
			DO1	DO2		DO3	DO4	DO5	DO6	DO7 (relay)	DO8 (relay)																																																																																																																							
	$\overline{RB}$		[0]	1	2	3	4	5	6	7	8																																																																																																																							
$\overline{RC}$	[0]		1	2	3	4	5	6	7	8																																																																																																																								
H	[0]		1	2	3	4	5	6	7	8																																																																																																																								
Nw	[0]		1	2	3	4	5	6	7	8																																																																																																																								
A1	0		[1]	2	3	4	5	6	7	8																																																																																																																								
A2	0		1	[2]	3	4	5	6	7	8																																																																																																																								
A3	[0]		1	2	3	4	5	6	7	8																																																																																																																								
A4	[0]	1	2	3	4	5	6	7	8																																																																																																																									
MUF	[0]	1	2	3	4	5	6	7	8																																																																																																																									
+Δw	[0]	1	2	3	4	5	6	7	8																																																																																																																									
-Δw	[0]	1	2	3	4	5	6	7	8																																																																																																																									
S69	<p><b>Direction of control action of the DOs on assigned message signals</b></p> <table border="1"> <thead> <tr> <th></th> <th>24 V = High</th> <th>0 V = High</th> </tr> </thead> <tbody> <tr> <td><math>\overline{RB}</math></td> <td>[0]</td> <td>1</td> </tr> <tr> <td><math>\overline{RC}</math></td> <td>[0]</td> <td>1</td> </tr> <tr> <td>H</td> <td>[0]</td> <td>1</td> </tr> <tr> <td>Nw</td> <td>[0]</td> <td>1</td> </tr> <tr> <td>A1/A2</td> <td>[0]</td> <td>1</td> </tr> <tr> <td>A3/A4</td> <td>[0]</td> <td>1</td> </tr> <tr> <td>MUF</td> <td>[0]</td> <td>1</td> </tr> </tbody> </table>		24 V = High	0 V = High	$\overline{RB}$	[0]	1	$\overline{RC}$	[0]	1	H	[0]	1	Nw	[0]	1	A1/A2	[0]	1	A3/A4	[0]	1	MUF	[0]	1																																																																																																									
		24 V = High	0 V = High																																																																																																																															
$\overline{RB}$		[0]	1																																																																																																																															
$\overline{RC}$		[0]	1																																																																																																																															
H		[0]	1																																																																																																																															
Nw		[0]	1																																																																																																																															
A1/A2		[0]	1																																																																																																																															
A3/A4	[0]	1																																																																																																																																
MUF	[0]	1																																																																																																																																
S70																																																																																																																																		
S71																																																																																																																																		
S72																																																																																																																																		
S73																																																																																																																																		
S74																																																																																																																																		
S75																																																																																																																																		
Limit value alarms	S76	<p><b>Assignment of A1/A2 and A3/A4 to process variables</b></p> <table border="1"> <thead> <tr> <th></th> <th>xd</th> <th>x1</th> <th>x</th> <th>w</th> <th>xv</th> <th>wv</th> <th>y</th> <th>y1</th> <th>y2</th> <th>AI 1</th> <th>AI 2</th> <th>AI 3</th> <th>AI 4</th> <th>AI 1A</th> <th>AI 2A</th> <th>AI 3A</th> <th>AI 4A</th> <th> xd </th> </tr> </thead> <tbody> <tr> <td>A1/A2</td> <td>[0]</td> <td>1</td> <td>2</td> <td>3</td> <td>4</td> <td>5</td> <td>6</td> <td>7</td> <td>8</td> <td>9</td> <td>10</td> <td>11</td> <td>12</td> <td>13</td> <td>14</td> <td>15</td> <td>16</td> <td>17*)</td> </tr> <tr> <td>A3/A4</td> <td>[0]</td> <td>1</td> <td>2</td> <td>3</td> <td>4</td> <td>5</td> <td>6</td> <td>7</td> <td>8</td> <td>9</td> <td>10</td> <td>11</td> <td>12</td> <td>13</td> <td>14</td> <td>15</td> <td>16</td> <td>17*)</td> </tr> </tbody> </table> <p>*) as of software version -B5</p>		xd	x1	x	w	xv	wv	y	y1	y2	AI 1	AI 2	AI 3	AI 4	AI 1A	AI 2A	AI 3A	AI 4A	xd	A1/A2	[0]	1	2	3	4	5	6	7	8	9	10	11	12	13	14	15	16	17*)	A3/A4	[0]	1	2	3	4	5	6	7	8	9	10	11	12	13	14	15	16	17*)																																																																							
			xd	x1	x	w	xv	wv	y	y1	y2	AI 1	AI 2	AI 3	AI 4	AI 1A	AI 2A	AI 3A	AI 4A	xd																																																																																																														
	A1/A2	[0]	1	2	3	4	5	6	7	8	9	10	11	12	13	14	15	16	17*)																																																																																																															
A3/A4	[0]	1	2	3	4	5	6	7	8	9	10	11	12	13	14	15	16	17*)																																																																																																																
S77																																																																																																																																		
S78	[0] 1 2	<p><b>Function of the limit value alarms A1/A2</b></p> <p>A1 max /A2 min A1 min /A2 min A1 max /A2 max</p>																																																																																																																																

Structure switch	switch position	Function																																																																	
Limit value alarms	S79	<p><b>Function of the limit value alarms A3/A4</b></p> <p>[0] A3 max /A4 min 1 A3 min /A4 min 2 A3 max /A4 max</p>																																																																	
	S80	<p><b>Display and setting of the limit values A1 to A4 in the process operation mode</b></p> <table border="1"> <thead> <tr> <th rowspan="2"></th> <th colspan="2">Limit value display</th> <th rowspan="2">adjustable</th> </tr> <tr> <th>w/x-digital display</th> <th>w bargraph display 1)</th> </tr> </thead> <tbody> <tr> <td>[0]</td> <td>no</td> <td>no</td> <td>no</td> </tr> <tr> <td>1</td> <td>A1 / A2</td> <td>no</td> <td>no</td> </tr> <tr> <td>2</td> <td>A1 / A2 / A3 / A4</td> <td>no</td> <td>no</td> </tr> <tr> <td>3</td> <td>A1 / A2</td> <td>no</td> <td>A1 / A2</td> </tr> <tr> <td>4</td> <td>A1 / A2 / A3 / A4</td> <td>no</td> <td>A1 / A2 / A3 / A4</td> </tr> <tr> <td>5</td> <td>A1 / A2</td> <td>A1 / A2</td> <td>A1 / A2</td> </tr> <tr> <td>6</td> <td>A1 / A2 / A3 / A4</td> <td>A1 / A2 A3 / A4</td> <td>A1 / A2 A3 / A4</td> </tr> </tbody> </table> <p>1) At S80 = 5/6 the limit values are displayed continuously, w is no longer displayed, a responding limit value flashes (recommended at S1 = 4).</p>		Limit value display		adjustable	w/x-digital display	w bargraph display 1)	[0]	no	no	no	1	A1 / A2	no	no	2	A1 / A2 / A3 / A4	no	no	3	A1 / A2	no	A1 / A2	4	A1 / A2 / A3 / A4	no	A1 / A2 / A3 / A4	5	A1 / A2	A1 / A2	A1 / A2	6	A1 / A2 / A3 / A4	A1 / A2 A3 / A4	A1 / A2 A3 / A4																															
	Limit value display			adjustable																																																															
	w/x-digital display	w bargraph display 1)																																																																	
[0]	no	no	no																																																																
1	A1 / A2	no	no																																																																
2	A1 / A2 / A3 / A4	no	no																																																																
3	A1 / A2	no	A1 / A2																																																																
4	A1 / A2 / A3 / A4	no	A1 / A2 / A3 / A4																																																																
5	A1 / A2	A1 / A2	A1 / A2																																																																
6	A1 / A2 / A3 / A4	A1 / A2 A3 / A4	A1 / A2 A3 / A4																																																																
w/x display	S81	<p><b>w/x digital display switching</b></p> <table border="1"> <thead> <tr> <th></th> <th>I</th> <th>II</th> <th>III</th> <th>IV</th> </tr> </thead> <tbody> <tr> <td>[0]</td> <td>x/xv</td> <td>w/wv</td> <td>-</td> <td>-</td> </tr> <tr> <td>1</td> <td>x/xv</td> <td>w/wv</td> <td>x1/xv</td> <td>-</td> </tr> <tr> <td>2</td> <td>x/xv</td> <td>w/wi1/wv</td> <td>-</td> <td>wE/wvE/wi2</td> </tr> <tr> <td>3</td> <td>x/xv</td> <td>w/wi1/wv</td> <td>x1/xv</td> <td>wE/wvE/wi2</td> </tr> <tr> <td>4</td> <td>x/xv</td> <td>-</td> <td>-</td> <td>-</td> </tr> <tr> <td>5</td> <td>-</td> <td>w/wv</td> <td>-</td> <td>-</td> </tr> <tr> <td>6</td> <td>-</td> <td>-</td> <td>x1/xv</td> <td>-</td> </tr> <tr> <td>7</td> <td>xv</td> <td>wv</td> <td>x1</td> <td>w</td> </tr> </tbody> </table> <p>Identification of the displayed variables by the w or x signal lamp: 1 = steady light, 0.5 = flashing light, 0 = off</p> <table border="1"> <thead> <tr> <th colspan="5">Display order</th> </tr> <tr> <th>I</th> <th>II</th> <th>III</th> <th>IV</th> <th></th> </tr> </thead> <tbody> <tr> <td>1</td> <td>0</td> <td>0.5 (0 at S81 = 6)</td> <td>0</td> <td>x signal lamp</td> </tr> <tr> <td>0</td> <td>1</td> <td>0</td> <td>0,5</td> <td>w signal lamp</td> </tr> </tbody> </table>		I	II	III	IV	[0]	x/xv	w/wv	-	-	1	x/xv	w/wv	x1/xv	-	2	x/xv	w/wi1/wv	-	wE/wvE/wi2	3	x/xv	w/wi1/wv	x1/xv	wE/wvE/wi2	4	x/xv	-	-	-	5	-	w/wv	-	-	6	-	-	x1/xv	-	7	xv	wv	x1	w	Display order					I	II	III	IV		1	0	0.5 (0 at S81 = 6)	0	x signal lamp	0	1	0	0,5	w signal lamp
	I	II	III	IV																																																															
[0]	x/xv	w/wv	-	-																																																															
1	x/xv	w/wv	x1/xv	-																																																															
2	x/xv	w/wi1/wv	-	wE/wvE/wi2																																																															
3	x/xv	w/wi1/wv	x1/xv	wE/wvE/wi2																																																															
4	x/xv	-	-	-																																																															
5	-	w/wv	-	-																																																															
6	-	-	x1/xv	-																																																															
7	xv	wv	x1	w																																																															
Display order																																																																			
I	II	III	IV																																																																
1	0	0.5 (0 at S81 = 6)	0	x signal lamp																																																															
0	1	0	0,5	w signal lamp																																																															
Restart conditions	S82	<p><b>Restart after mains recovery</b></p> <p>[0] last operating mode, last w, last y 1 manual and internal operation, last w, in K-and two-position controllers Ys, in three-position controllers last y</p>																																																																	
	S83	<p><b>optical signaling after mains recovery</b></p> <p>[0] without flashing of the w/x digital display 1 with flashing of the w/x digital display</p>																																																																	

Structure switch	switch position	Function																												
Serial interface	S84	<p><b>Serial interface (slot 4)</b></p> <p>0 without            [1] with serial interface, with lock via RC            2<sup>1)</sup> with serial interface, with lock via CB            3<sup>1)</sup> with serial interface, without lock            1) as of software version –C1</p>																												
	S85	<p><b>Data transfer</b></p> <table border="1"> <thead> <tr> <th>Reception by DR21</th> <th>Control signal CB<sub>DI</sub>/CB<sub>ES</sub></th> <th>Source for w<sub>E</sub></th> <th>y<sub>N</sub></th> </tr> </thead> <tbody> <tr> <td>0 nothing</td> <td>only</td> <td>w<sub>EA</sub></td> <td>y<sub>N</sub></td> </tr> <tr> <td>[1] Configuring</td> <td>CB<sub>DI</sub></td> <td></td> <td></td> </tr> <tr> <td>2 Configuring</td> <td>CB<sub>DI</sub> ∨ CB<sub>ES</sub></td> <td>w<sub>ES</sub></td> <td>y<sub>ES</sub></td> </tr> <tr> <td>3 Process var.</td> <td>CB<sub>DI</sub> ∧ CB<sub>ES</sub></td> <td></td> <td></td> </tr> <tr> <td>4 Status register</td> <td>CB<sub>DI</sub> ∨ CB<sub>ES</sub></td> <td>w<sub>EA</sub></td> <td>y<sub>N</sub></td> </tr> <tr> <td>5</td> <td>CB<sub>DI</sub> ∧ CB<sub>ES</sub></td> <td></td> <td></td> </tr> </tbody> </table>	Reception by DR21	Control signal CB <sub>DI</sub> /CB <sub>ES</sub>	Source for w <sub>E</sub>	y <sub>N</sub>	0 nothing	only	w <sub>EA</sub>	y <sub>N</sub>	[1] Configuring	CB <sub>DI</sub>			2 Configuring	CB <sub>DI</sub> ∨ CB <sub>ES</sub>	w <sub>ES</sub>	y <sub>ES</sub>	3 Process var.	CB <sub>DI</sub> ∧ CB <sub>ES</sub>			4 Status register	CB <sub>DI</sub> ∨ CB <sub>ES</sub>	w <sub>EA</sub>	y <sub>N</sub>	5	CB <sub>DI</sub> ∧ CB <sub>ES</sub>		
	Reception by DR21	Control signal CB <sub>DI</sub> /CB <sub>ES</sub>	Source for w <sub>E</sub>	y <sub>N</sub>																										
	0 nothing	only	w <sub>EA</sub>	y <sub>N</sub>																										
	[1] Configuring	CB <sub>DI</sub>																												
	2 Configuring	CB <sub>DI</sub> ∨ CB <sub>ES</sub>	w <sub>ES</sub>	y <sub>ES</sub>																										
	3 Process var.	CB <sub>DI</sub> ∧ CB <sub>ES</sub>																												
	4 Status register	CB <sub>DI</sub> ∨ CB <sub>ES</sub>	w <sub>EA</sub>	y <sub>N</sub>																										
	5	CB <sub>DI</sub> ∧ CB <sub>ES</sub>																												
	S86	<p><b>Data transfer rate</b></p> <p>[0] 9600 bps            1 4800 bps            2 2400 bps            3 1200 bps            4 600 bps            5 300 bps</p>																												
S87	<p><b>Cross parity</b></p> <p>[0] even            1 odd</p>																													
S88	<p><b>Longitudinal parity position</b></p> <p>[0] without            1 after ETX            2 before ETX</p>																													
S89	<p><b>Longitudinal parity</b></p> <p>[0] normal            1 inverted</p>																													
S90	<p><b>Station number</b></p> <p>[0] 0            to to            125 125</p>																													
S91	<p><b>Time monitoring CB (ES)</b></p> <p>[0] without time monitoring            1 to 1 s to            25 25 s</p>																													
S92	<p><b>see structure switch S33 following</b></p>																													

Table 5-5 Structure switches

The serial interface in the DR21 must be set as follows for operation on the PROFIBUS-DP.

Structure switch	Setting
S84	1
S85	2
S86	0
S87	0
S88	0
S89	0
S90	3 to 125
S91	0 to 9

### 5.4.6 Set UNI-module CAE3

The CAE3 menu is only offered in the selection mode if the structure switch S6 is set = 4 to 7 (input signal for AI3 is generated by the UNI-module)

With this menu the measuring range can be determined for the various signal transmitters (selection with S8 and S9) and fine adjustment can be made.

S6	[0]	<b>Input signal AI3 (slot 1) and transmitter fault message</b>		
	1	0...20 mA	or U,R,P,T	without MUF
	2	0...20 mA	or U,R,P,T	with MUF
	3	4...20 mA	or U	without MUF
	4	4...20 mA	or U	with MUF
	5	UNI module	Min at sensor break	without MUF
	6	UNI module	Max at sensor break	without MUF
	7	UNI module	Min at sensor break	with MUF
S8	[0]	<b>Input signal AI3 (slot 1) with UNI-module (only active at S6=4/5/6/7)</b>		
	1	mV (linear), with measuring range plug U or I		
	2	Thermocouple with internal reference point		
	3	Thermocouple with external reference point		
	4	PT100 4-wire connection		
	5	PT100 3-wire connection		
	6	PT100 2-wire connection		
	7	Resistance potentiometer with	$R < 600 \Omega$	
S9	[0]	<b>Thermocouple type AI3 (slot 1) with UNI-module (only active at S8=1/2)</b>		
	1	Type L		
	2	Type J		
	3	Type K		
	4	Type S		
	5	Type B		
	6	Type R		
	7	Type E		
	8	Type N		
	9	Type T		
	10	Type U		
S10	[0]	<b>Temperature unit AI3 (slot 1) with UNI-module (only active at S8=1/2/3/4/5)</b>		
	1	Degrees Celsius		
	2	Degrees Fahrenheit		
		Kelvin		

Table 5-6 Excerpt from the structure switch table

● **Calling, setting and leaving the CAE3 menu**

- Press the shift key (6) for about 5 s until "PS" flashes in the y display (9).
- Select the CAE3 menu with the Δw keys (14), (15)
- To enter the CAE3 menu, press the Enter key (11) for about 3 s.
- Select the CAE3 parameters with the Δy keys (7), (8)
- Set the CAE3 parameters with the Δw keys (14), (15)
- You return to the process operation mode by pressing the Exit key (16) twice.

● **The following parameters are available in the CAE3 menu for setting the measuring range and adjustment**

y display parameter name	w/x display setting range	Factory setting	Display unit	Meaning/function of parameter	Display and function only at:
tb <sup>1)</sup>	0 to 400.0	50	°C, °F, K	Reference temperature external reference point	S8 = 2
Mr	0.00 to 99.99	10	Ω	Measuring of RLn. (Pt100-2L)	S8 = 5
Cr	Difference value to Mr		Ω	Calibr. of RLn. (Pt100-2L)	
MP	_---- to ____		physical Dimension depending on the measuring variable <sup>4)</sup>	Decimal point measuring range	S8 = 0 to 7
MA <sup>2)</sup>	-19999 to 9999	0.0		Measuring range start	
ME <sup>2)</sup>	-19999 to 9999	100.0		Measuring range full scale	
CA	act. measured value ± ΔA <sup>3)</sup>			Calibr. Meas. range Start	
CE	act. measured value ± ΔE <sup>3)</sup>			Calibr. Meas. range full scale	
PC <sup>5)</sup>	no, YES, no C	no C	-	Preset Calibration	S8 = 0 to 5

Table 5-7 CAE3-menu parameter list

- 1) If no specified thermocouple type is selected with S9 = 10, the parameter tb has no effect.
- 2) The set measuring range is transferred as a standardized number range from 0 to 1 to the controller. If the measured value mode is to be displayed physically, the offline parameters dP, dA and dE must be set accordingly.
- 3) For S8 = 0 to 5 : ΔA, ΔE do not appear as own parameters. The correction values for calibrating the start or full scale of the measuring range are arbitrary.
- 4) For S8 = 6, 7 the unit of the CA/CE display is in %.
- 5) For S8 = 0 to 5 : With ΔA = ΔE = 0, PC = no C is displayed, it is not possible to switch over with the Δw-keys (7), (8) to PC = YES. By adjusting CA/CE, PC = no is displayed, switching to PC = YES is possible. If PC = YES is displayed ΔA = ΔE = 0 can be set with the Enter key (press for approx. 3 s), whereupon PC = no C is displayed.

The corresponding settings of the CAE3 menu for the different signal transmitters are described below.

The range and thus the current measured value can be corrected with the parameters CA/CE to compensate tolerances of the transmitters or adjustments with other display instruments (for S 8 = 0 to 5).

To avoid measuring errors, the assembly instructions in chapter 4.2.2, page 130 and especially the maximum permissible line resistances (see table 2-3, page 41) must be observed in the determination of the measuring range.

#### 5.4.6.1 Measuring range for mV (S8 = 0)

- **MA/ME – set measuring range**

Call parameters MA, ME, set range start and full scale:  
Measuring range limits  $-175 \text{ mV} \leq \text{MA} \leq \text{ME} \leq +175 \text{ mV}$

- **CA/CE – fine adjustment (only if necessary)**

Call parameter CA,  
Set signal to start of scale  
Correct the display with CA if necessary

Call parameter CE,  
Set signal to full scale,  
Correct the display with CE if necessary

#### 5.4.6.2 Measuring range for U, I (S8 = 0)

only with measuring range plug 6DR2805-8J

- **MA/ME – set measuring range**

Call parameters MA, ME, set range start and full scale:  
Measuring range limits  $-175 \text{ mV} \leq \text{MA} \leq \text{ME} \leq +175 \text{ mV}$

Initialization in the measuring range plug

0 to 10V or 0 to 20mA	signal corresponds to	MA = 0mV	ME = 100mV
2 to 10V or 4 to 20mA	signal corresponds to	MA = 20mV	ME = 100mV

- **CA/CE – fine adjustment (only if necessary)**

Call parameter CA,  
Set signal to start of scale  
Correct the display with CA if necessary

Call parameter CE,  
Set signal to full scale,  
Correct the display with CE if necessary

#### 5.4.6.3 Measuring range for thermocouple with internal reference point (S8 = 1)

- **MA/ME – set measuring range**

Call parameters MA, ME, set the start of scale and full scale according to the thermocouple type (S9) and the temperature unit (S10).

- **CA/CE – fine adjustment (only if necessary)**

Call parameter CA,  
Set signal to start of scale  
Correct the display with CA if necessary

Call parameter CE,  
Set signal to full scale,  
Correct the display with CE if necessary

#### 5.4.6.4 Measuring range for thermocouple with external reference point (S8 = 2)

- **tb – external reference points-temperature**

Set the external reference point temperature with tb. Specify temperature unit with S10.  
Attention: tb has no effect at S9 = 10!

- **MA/ME – set measuring range**

Call parameters MA, ME, set the start of scale and full scale according to the thermocouple type (S9) and the temperature unit.

- **CA/CE – fine adjustment (only if necessary)**

Call parameter CA,  
Set signal to start of scale  
Correct the display with CA if necessary

Call parameter CE,  
Set signal to full scale,  
Correct the display with CE if necessary

#### 5.4.6.5 Measuring range for PT100 four-wire and three-wire connection (S8 = 3,4)

- **MA/ME – set measuring range**

Call parameters MA, ME, set range start and full scale:  
Measuring range limits  $-200\text{ °C} \leq MA \leq ME \leq +850\text{ °C}$   
Specify temperature unit with S10.

- **CA/CE – fine adjustment (only if necessary)**

Call parameter CA,  
Set signal to start of scale  
Correct the display with CA if necessary

Call parameter CE,  
Set signal to full scale,  
Correct the display with CE if necessary



#### 5.4.6.6 Measuring range for PT100 two-wire connection (S8 = 5)

- **MR/CR adjustment of the feed line resistance**

Path 1: The feed line resistance is known.

- Enter the known resistance with parameter MR.–
- CR is ignored.

Path 2: The feed line resistance is not known.

- Short circuit PT100-sensor at the measuring point.
- Call parameter CR and press the Enter key (11) until 0.00  $\Omega$  is displayed.
- MR displays the measured resistance value

- **MA/ME – set measuring range**

Call parameters MA, ME, set range start and full scale:  
Measuring range limits  $-200\text{ }^{\circ}\text{C} \leq \text{MA} \leq \text{ME} \leq +850\text{ }^{\circ}\text{C}$   
Specify temperature unit with S10.

- **CA/CE – fine adjustment (only if necessary)**

Call parameter CA,  
Set signal to start of scale  
Correct the display with CA if necessary

Call parameter CE,  
Set signal to full scale,  
Correct the display with CE if necessary

#### 5.4.6.7 Measuring range for resistance potentiometer (S8 = 6, 7)

Path 1: The start and end values of the R- potentiometer are known.

- Call parameter **MA, ME**, set start of scale and full scale:  
 $0\ \Omega \leq \text{MA} \leq \text{ME} \leq 600\ \Omega / 2.8\ \text{k}\Omega$
- Parameters **CA/CE** display at  $R=\text{MA}\ 0\%$ , at  $R=\text{ME}\ 100\ \%$ .  
The following applies for a 3-wire connection:  $R = R_p + R_{L4}$   
The following applies for a 4-wire connection:  $R = R_p + R_{L1} + R_{L4}$

Path 2: The start and end values of the R- potentiometer are not known.

- Call parameter **CA** ,  
Move output to position 0 %, press the Enter key (11) until 0.0 % is displayed.
- Call parameter **CE**,  
Move output to position 100 %, press the Enter key until 100.0 % is displayed.
- Parameters **MA/ME** show the appropriate resistance values.
- **MP** must be set so that there is no 'exceeding of the range' (display (3): oFL)

### 5.4.7 APSt (All Preset) Reset to factory setting

APSt serves to reset all controller functions (parameters and structures) to the factory setting. We recommend you to run the APSt function first if major changes are to be made to the configuration. The controller is in offline operation in the structuring mode.

#### NOTICE

The APSt function cannot be canceled.

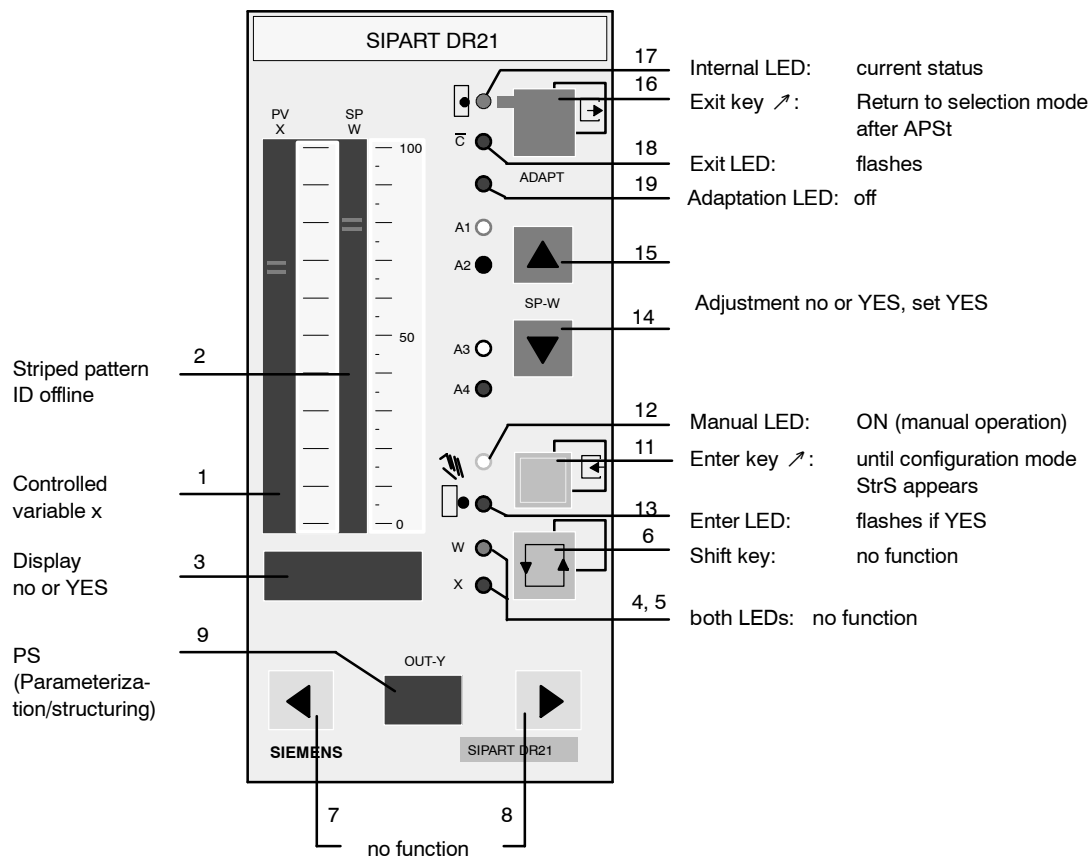

Figure 5-8 Control and display elements in the structuring mode APSt

No appears after jumping to the structuring mode APSt with the Enter key (11). Set YES with +Δw key (14, 15) and press the Enter key (11) until the configuration mode StrS appears. The Preset function is run. Select structuring mode Strs by pressing the Enter key and re-structure the controller.

The offline and online parameters must also be reset.

## 5.5 CPU self-diagnostics

The CPU runs safety diagnostics routines which run after only one reset or cyclically. The CPU is familiar with two different types of reset:

### Power On-Reset

always take place when the 5 V supply drops below 4.45 V, i.e. the power supply is interrupted for longer than specified in the technical data.

All parameters and structures are reloaded from the user program memory into the RAM. The current process variables and the controller status are reloaded from the EEPROM for these data.

At S83 = 1 the digital w/x- display flashes as an indication after a Power-On-Reset, acknowledgement is by the Shift key (6) for w/x digital display.

With S83 = 0, the flashing is suppressed.

### Watch\_dog Reset

The processor has an integrated watchdog which monitors the cyclic program runs independently.

When a watch-dog reset occurs the parameters and structures from the user program memory are loaded into the RAM. The current process variables and the controller status are read out of the RAM for further processing.

There are no flashing signals on the front module.

tESt appears for a maximum 5 s in the digital w/x display after every reset.

Every detected error of the self-monitoring leads to a flashing error message on the digital w/x display with defined states of the analog and digital outputs.

The reactions listed in the table are only possible of course (since this is a self-test) if the errors occur in such a way that the appropriate outputs or the front module are still controlled properly or the outputs themselves are still functioning.

Error message w/x display	Monitoring of	Monitoring time	Primary cause of the error/remedy
during monitoring tESt in the case of an error CPU $\downarrow$	EEPROM, RAM, EPROM	after every reset	monitored components of the CPU or EEPROM defective/change front module
MEM $\downarrow$	EEPROM	when storing	
OP.1.* 1)	Data communication slot 1: UNI-module	cyclic	Option not plugged, defective or S6 does not correspond to plugged option / plug or change option or correct S6.
OP.*.3 1)	Data communication slot 3 4DO + 2DI or 5 DI option	cyclic	Option not plugged, defective or S22 does not correspond to plugged option / plug or change option or correct S22 <sup>2)</sup>

1) also double error display OP.1.3 possible. \* means digit dark

2) If 2DO relay is selected with S 22 = 3, no monitoring takes place.

At DI3 to DI7, S22 = 2 the effect of the digital inputs (after inversion) are set to 0 in the event of an error.

Table 5-8 Error message of the CPU



## 6 Commissioning

### 6.1 Adapting the direction of control action to the controlled system

- **Definitions**

Normal control action system

Rising  $y$  causes rising  $x$ ; e.g. an increasing energy supply or mass flow causes a rising temperature.

Normal effecting actuator (valve):

Increasing current or positioning command  $+\Delta y$  cause the actuating element (increasing  $y$ ) to open, e.g. more energy or greater mass flow.  $y_{\text{displ.}}$  is the displayed manipulated variable.

The direction of control action is referred to the controlled variable  $x_1$ . The following statements apply for transmitters with normal control action (increasing physical variable causes increasing transmitter current), increasing process display ( $dE > dA$ ) and no falling characteristic in the linearizers.

- **Direction of control action of system and final control element known**

K-controller

The following is prescribed:			Select the desired control action here:				This gives the settings of S46 and S55 and the mode of operation of the controller			
Direction of control action of the system	Direction of control action of the actuator	Direction of control action of the system and the actuator	20 mA on	pressing the right key causes in manual operation			S46	Kp (cP)	S55	Y displ. =
				actuating current ly	valve	Actual value/ controlled variable				
normal	normal	normal	100 %	rises	opens	rises	0	pos.	0	y
	reversing	reversing	0 %	falls	opens	rises	1	neg.	1	100 % -y
reversing	normal	reversing	0 %	falls	closes	rises	1	neg.	1	100 % -y
			100 %	rises	opens	falls	1	neg.	0	y
	reversing	normal	100 %	rises	closes	rises	0	pos.	0	y
			0 %	falls	opens	falls	0	pos.	1	100 % -y

Two more lines could be added to the table which are useless in practice: normal action system in which the actual values falls with a rising change in the manipulated variable.

Table 6-1 Direction of control action and y-display direction of control action of the system- and final control element direction of control action in K-controllers

S-controller

The following is prescribed:			Select the desired control action here:			This gives the settings of S46 and S55 and the mode of operation of the controller			
Direction of control action of the system	Direction of control action of the actuator	Direction of control action of the system and actuator	pressing the right key causes in manual operation:		Actual value/controlled variable rises	S46	Kp (cP)	S55	Ydispl. =
			active switching output is	valve					
normal	+Δy opens	normal	+Δy	opens	rises	0	pos.	0	y <sub>R</sub>
reversing	+Δy opens	reversing	-Δy	closes	rises	1	neg.	1	100 % - y <sub>R</sub>
			+Δy	opens	falls	1	neg.	0	y <sub>R</sub>

If the actuator is connected reversing as an exception (+Δy closes), the position feedback must also be reversed and the controller direction of control action (Kp) negated.

Table 6-2 Controller direction of control action and y-display direction of control action of the system- and final control element direction of control action in S-controllers

● **Direction of control action of system and final control element unknown**

Put controller in manual mode, leave structure switches S46 and S55 in factory setting (0).

- **Determine direction of control action of the final control element**

Press the right manipulated variable adjustment key with the process switched off if possible or close to its safety position and observe whether the final control element opens or closes. If the final control element opens this means it has normal action. If closing is determined in S-controllers, the connections + Δ y and - Δ y should be switched.

The final control element can be observed as follows (if the direction of control action of the system is known):

- normal control action system: rising x means normal control action actuator
- reversing system: falling x means normal control action actuator
- in S-controllers and already correctly connected position feedback  
 rising y-display means normal control action actuator
- The final control element can be monitored additionally at the installation location.

- **Determine the direction of control action of the system**

Press the right output adjustment key and observe on the actual value display whether the controlled variable (actual value) rises or falls. Rising means normal control action system with normal action actuator, reversing control action system with reversing actuator. Falling means reversing control action system with normal control action actuator, normal control action system with reversing actuator. With the direction of control action of actuator and system determined in this way, the controller can be set according to table 6-1 and 6-2.

## 6.2 Setting of actuating time in K-controllers (S2 = 0)

- **Actuating time tP, tM**

Set the actuating time tP (open) or tM (closed) to the actuating time of the following actuator. If the control circuit is to be settled additionally, e.g. to avoid hard impact on the actuating drive, tP, tM can be further increased in Automatic operation.

The value of tP is usually set identical to the value of tM.

## 6.3 Adaptation of the S-controller to the actuating drive

- **Output Two-position controller for heating/cooling (S2 = 1)**

The setting range y can be divided into two sections. The offline-parameters Y1 and Y2 and the online-parameters YA and YE determine these sections (see fig. 3-24, page 98.)

The period duration and the shortest turn-on- and turn-off duration are determined in the cooling branch (section [YA, Y1]) by the online-parameters tM and tA and in the heating branch (section [Y2, YE]) by the online parameters tP and tE.

The period durations tP and tM should be chosen as great as possible, whereby the following should be observed:

- Great values of tP and tM result in low wear of the internal and external switchgear.
- Large values cause a periodic fluctuation of the controlled variable x which is greater the faster the controlled system is.

- **S-controller with internal feedback (S2 = 2)**

Set the actuating time of the actuating drive (e.g. 60 s) with the online-parameters tP, tM (0.1 to 1000 s).

---

### NOTICE

The factory setting is 1 s!

---

The online-parameter tE (minimum turn-on duration) should be selected at least great enough that the actuating drive starts moving reliably under consideration of the power switches connected before it. The greater the value of tE, the more resistant to wear and more gently the switching and drive elements connected after the controller operate. Large values of tE require a greater dead band AH in which the controller cannot control defined because the resolution of the controlled variable diminishes with increasing turn-on duration.

The factory setting for tE is 200 ms. This corresponds to a y-resolution in a 60-s-actuating drive of:

$$\Delta y = \frac{100 \% \cdot tE}{tP \text{ (or } tM)} = \frac{100 \% \cdot 200 \text{ ms}}{60 \text{ s}} = 0.33 \%$$

The minimum possible resolution is transferred with the system gain  $K_s$  to the controlled variable

$$\Delta x = K_s \cdot \Delta y$$

The parameter  $t_A$  (minimum turn-off duration) should be chosen at least great enough that the actuating drive is safely disconnected under consideration of the power switches connected before it before a new pulse appears (especially in the opposite direction). The greater the value of  $t_A$ , the more resistant to wear the switching- and drive elements connected after the controller operate and the greater the dead time of the controller under some circumstances. The value of  $t_A$  is usually set identical to the value of  $t_E$ .

$t_A = t_E = 120$  to  $240$  ms are recommended for  $60$  s actuating drives. The more restless the controlled system, the greater the two parameters should be selected if this is reasonably justified by the controller result.

The response threshold  $AH$  must be set corresponding to the set  $t_E$  and the resulting  $\Delta y$  or  $\Delta x$ . The following condition must be satisfied:

$$AH > \frac{\Delta x}{2} \quad \text{or} \quad AH > \frac{K_s \cdot t_E \cdot 100 \%}{2 \cdot t_P \text{ (or } t_M)}$$

Otherwise the controller outputs positioning increments although the control deviation has reached the smallest possible value due to the finite resolution. For setting  $AH$ , see chapter 5.4, page 154.

● **S-controller with external feedback (S2 = 3)**

The position control circuit is optimized with the online-parameters  $t_P/t_M$ . The same relationships apply as in the S-controller with internal position feedback whereby the dynamic of the position control circuit (non-linearities, follow-up) is added to the criteria of the processability of the positioning increments by the final control element. It will usually be necessary to select  $t_P/t_M$  and the resulting response threshold smaller than in the S-controller with internal position feedback for the above mentioned reasons.

The position control circuit is optimized in manual mode. To do this,  $S54$  is set to  $0$  for the optimizing phase so that the manual manipulated variable is preset as an absolute value. It must be noted that the active manipulated variable trails the manipulated variable display due to the actuating time of the actuator.

In the case of non-linearity in the position control circuit, the optimization must take place in the range of greatest slope.

Procedure for optimization of the position control circuit:

- Set  $S54$  to  $0$  (position controller also active in manual mode)
- Set  $t_A$  and  $t_E$  so that the actuating drive can **just** process the positioning increments (see S-controller with internal feedback).
- Set 1st order filter of the  $y_R$  -input ( $t_1$ ,  $2$ ,  $3$  or  $4$ ) to  $0.01$   $TP/TM$  (real actuating time of the drive).
- Increase  $t_P/t_M$  until the position control circuit overshoots due to small manual changes in the manipulated variable (observe opposite pulse on the  $\Delta y$ -LEDs (10) in the  $y$ -display).



- Reduce tP/tM slightly again until the position control circuit settles.
- Reset S54 to 1 (position controller no longer active in manual mode)

## 6.4 Setting the filter and the response threshold

Set the structure switch S3 to the mains frequency 50 or 60 Hz existing in the system (factory setting 50 Hz) to suppress faults due to the mains frequency.

- **Filter of first order of analog inputs**

The filter time constants (t1 to t4) for the input filters are set in the onPA-parameterization mode and to the greatest possible value permitted by the control circuit without affecting the controllability (t1 to t4 < Tg). When using the adaptation method the appropriate input filters must be optimized.

- **Adaptive, non-linear filters of the control difference**

Since the dead zone sets itself automatically and its size is therefore unknown, the time tF (onPA) can only be selected so great that the control circuit cannot oscillate in the case of a large dead zone (tF less than Tg). When using the D-part (PD, PID) the use of the adaptive, non-linear filter is strongly recommended because the input noise amplified by  $K_p \cdot v_v$  can be suppressed.

If filters are required, they must be set before using the adaptation method.

- **Optimization of the response threshold AH**

If the output of the controller is to additionally settled or the load on the actuator reduced, the necessary response threshold AH can be increased. The response threshold AH is given in three-position controllers (S2 = 2, 3) by the setting of tE (see chapter 6.3, page 183) and must automatically be greater than zero. In K-controllers and two-position controllers (S2 = 0, 1) a response threshold of approx. 0.5 % is recommendable.

It must be taken into account that the remaining control error can assume the value of the set response threshold.

## 6.5 Automatic setting of control parameters by the adaptation method

see chapter 3.9 "Adaptation (S48)", page 113

The adaptation method should always be preferred to manual settings because the control results with the parameters gained from adaptation are better especially in slow controlled systems and this saves optimization time.

- **Presetting**

- **S48 selecting the control behavior (structuring mode StrS)**

No adaptation is possible when S48 = 0. In position 1 a control behavior without overshoot is offered. In position 2 changes in the command variables can be expected with a maximum 5 % overshoot.

- **tU: Monitoring time (parameterization mode AdAP)**

tU is only necessary for the error messages and has no influence on the quality of identification. It can always be started with tU = OFF. Otherwise tU must be set at least twice as great as the transient time  $T_{95}$  of the controlled system. After successful adaptation tU is automatically set to  $2T_{95}$ . At  $tU < 0.1$  h (6 min), tU = OFF is displayed.

- **Pv: Direction of the step command (parameterization mode AdAP)**

The direction of the controlled variable change from the set operating point is selected with this configuring switch:  $x_{\text{manual}} \pm \Delta x = \pm k_s (y_{\text{manual}} \pm \Delta y)$ . In controlled systems with batches it is recommendable to perform one adaptation with rising x and one with falling x. The averaged or dynamically more uncritical parameters can then be used for the control.

- **dy: Amplitude of the step command (parameterization mode AdAP)**

The step command must be selected so great that the controlled variable changes by at least 4 % and the controlled variable change must be 5 times the average noise level. The greater the controlled variable change, the better the identification quality. Controlled variable changes of approx. 10 % are recommended.

- **Notes on the adaptation results**

- **D-part**

In S-controllers and K-controllers on 1st order controlled systems, the D part brings no noticeable advantages due to the finite actuating time  $T_y$  or for reasons founded in the control theory. The disadvantages in the form of wear on the positioning side dominate.

- **Range limits**

If one of the determined parameters reaches its range limits, the other parameter should be adjusted slightly in the opposite direction of action.

If 8th order systems are identified, the determined  $k_p$  must be reduced for safety reasons. The determined  $K_p$  must be increased again if the control circuit is too slow (uncritical).

**- Kp variation**

In the special cases 1st order controlled system in connection with PI and PID controllers and 2nd order controlled systems in connection with PID-controllers, the  $K_p$  can be varied freely. In controller design according to the amount optimum,  $K_p$  can be increased up to 30 % as a rule without the control behavior becoming critical.

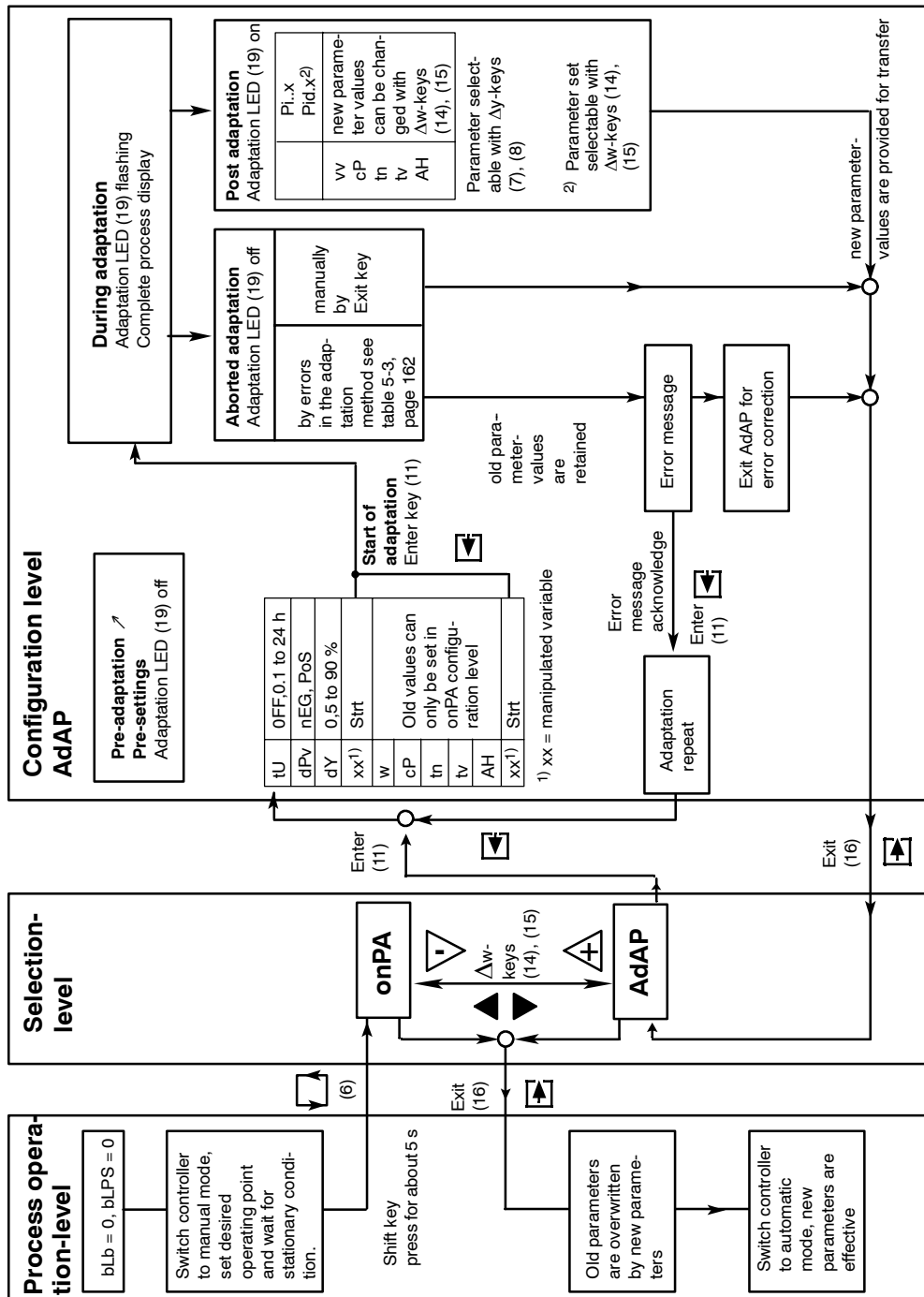

Figure 6-1 Overview configuration level AdAP

## 6.6 Manual setting of the control parameters without knowledge of the plant behavior

The control parameters for optimum control of the system are not yet known in this case. To keep the control circuit stable in all cases, the following factory settings must be made:

Proportional action factor	$K_p$	=	0.1
Integral action time	$T_n$	=	9984 s
Derivative action time	$T_v$	=	oFF

### ● P-controller (control signal P = high)

- Set the desired setpoint and set the control difference to zero in manual operation.
- The operating point necessary for the control difference is set automatically in manual operation at  $Y_o = AUto$  (factory setting). The operating point can also be set manually by setting the online-parameter  $y_o$  to the desired operating point.
- Switch to automatic operation.
- Increase  $K_p$  slowly until the control loop tends to oscillate due to slight setpoint changes.
- Reduce  $K_p$  slightly until the oscillations disappear.

### ● PD-controller (control signal P = high)

- Set the desired setpoint and set the control difference to zero in manual operation.
- The operating point necessary for the control difference is set automatically in manual operation at  $Y_o = AUto$  (factory setting). The operating point can also be set manually by setting the online-parameter  $y_o$  to the desired operating point.
- Switch to automatic operation.
- Increase  $K_p$  slowly until the control loop tends to oscillate due to slight setpoint changes.
- Switch  $T_v$  from oFF to 1 s.
- Increase  $T_v$  until the oscillations disappear.
- Increase  $K_p$  slowly until oscillations reappear.
- Repeat the setting according to the two previous steps until the oscillations can no longer be eliminated.
- Reduce  $T_v$  and  $K_p$  slightly until the oscillations are eliminated.

- **PI-controller (control signal P = Low)**

- Set the desired setpoint and set the control difference to zero in manual operation.
- Switch to automatic operation.
- Increase  $K_p$  slowly until the control loop tends to oscillate due to slight setpoint changes.
- Reduce  $K_p$  slightly until the oscillations disappear.
- Reduce  $T_n$  until the control loop tends to oscillate again.
- Increase  $T_n$  slightly until the tendency to oscillate disappears.

- **PID-controller (control signal P = Low)**

- Set the desired setpoint and set the control difference to zero in manual operation.
- Switch to automatic operation.
- Increase  $K_p$  slowly until the control loop tends to oscillate due to slight setpoint changes.
- Switch  $T_v$  from OFF to 1 s.
- Increase  $T_v$  until the oscillations disappear.
- Increase  $K_p$  slowly again until the oscillations reappear.
- Repeat the setting according to the previous two steps until the oscillations cannot be eliminated again.
- Reduce  $T_v$  and  $K_p$  slightly until the oscillations stop.
- Reduce  $T_n$  until the control loop tends to oscillate again.
- Increase  $T_n$  slightly until the tendency to oscillate disappears

## 6.7 Manual setting of the control parameters after the transient function

If the transient function of the controlled system is active or can be determined, the control parameters can be set according to the setting guidelines specified in the literature. The transient function can be recorded in the „Manual operation” position of the controller by a sudden change in the manipulated variable and the course of the controlled variable registered with a recorder. This will roughly give a transient function corresponding to the one shown in figure 6-2.

Good average values from the setting data of several authors give the following rules of thumb:

### P-controller:

$$\text{Proportional gain factor } K_p \approx \frac{T_g}{T_u \cdot K_s}$$

### PI-controller:

$$\text{Proportional gain factor } K_p \approx 0.8 \cdot \frac{T_g}{T_u \cdot K_s}$$

$$\text{Integral action time } T_n \approx 3 \cdot T_u$$

### PID-controller:

$$\text{Proportional gain factor } K_p \approx 1.2 \cdot \frac{T_g}{T_u \cdot K_s}$$

$$\text{Integral action time } T_n \approx T_u$$

$$\text{Derivative action time } T_v \approx 0.4 T_u$$

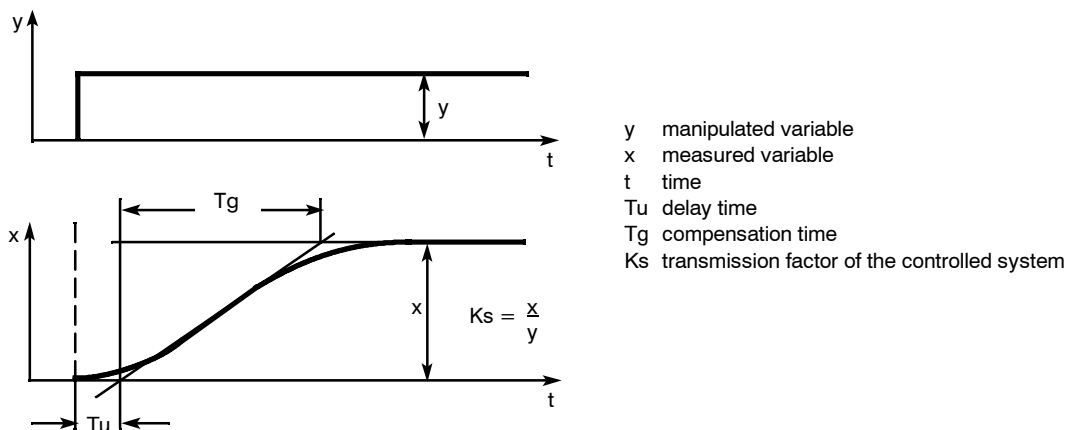

Figure 6-2 Transient function of a controlled system with compensation





## 7 Application examples for configuring the controller

### 7.1 General

Frequent applications/connections of the SIPART DR21 controllers in the form of configuration examples are listed below. The circuits are sorted according to their application **S**-controller, **K**-controller, control unit/process display or two-position controller. All input and output connections and the order numbers of the respective required controllers or accessory modules are stated. A principle circuit diagram of the control circuit and a short description make comprehension easier

We have purposely described the simple applications in very great detail to help the technician above all who only needs to design these circuits very occasionally.

#### Mains voltage

As shown, the power supply must be fused and the PE conductor connected. The permissible power supply range must be stated respectively with the type number of the controller.

**Fuses and connecting leads are not supplied with the controllers.**

#### Input circuits

A wide variety of input circuits are shown. Please note that the supply voltage remaining for the transmitter may only be 15 V DC in the worst case when a two-wire transmitter is fed by the SIPART DR21 and the analog inputs AI1/AI2 are used at the same time.

#### Output circuits

The outputs are represented uniformly. In S-controllers, the switching outputs are output via relays which may be loaded with a max. 250 V AC. If the position outputs of the S-controller are desired with digital signals, the digital outputs DO1 and DO2 must be used.

**If inductances (e.g. positioning motors, contactors, etc.) are switched with the planned relay outputs, an adequate interference suppression must be provided for on the system side by wiring with RC-combinations or other suitable means in order to achieve EMC protection aims.**

- **Configuring**

### **Structure switches S**

All controllers are supplied with the specified factory settings and must be structured to suit the application during commissioning.

**The switch positions for the respective application which deviate from the factory setting are listed in the examples.**

In addition other settings may be necessary due to system-specific criteria.

The following configuration examples have exclusively parallel circuits. Therefore the structure switches which relate to the serial interface are not specified.

### **Parameters onPA and oFPA**

The controllers must be adapted in every case using the system data. The factory setting of the control parameters must be selected so that the control loop does not tend to oscillate even under worst case conditions ( $K_p = 0, 1$ ,  $T_n = 9984$  s).  $K_p$  and  $T_n$  or  $y_0$  and if necessary  $T_v$  and  $AH$  must be set.

### **Control algorithm**

All configuration examples (except Z1) are shown for PI or PID behavior. Switching to P or PD behavior is possible with a digital input signal (structure switch S27). In the SIPART DR21 as an S-controller, a P-or PD-controller operation is only possible with external position feedback (S2=3).

## 7.2 Working with different setpoints

Function diagrams are shown on the following pages which illustrate on the time axis how setpoints change when

- the Internal/External key (16) on the front is pressed
- the structured functions of the digital input DI are triggered with logic 1 or logic 0.

The structure switches named next to the examples must be put in the specified positions for the illustrated functions. Structure switches not listed are in the factory setting.

### Example 1

two-setpoint operation as a fixed setpoint controller  
(see chapter 3.4.2, page 59)

At  $S81 = 2/3$  both setpoints can be called with the key (6) in the four-digit display (3) and then adjusted with the keys (14), (15) on the front of the instrument. Switching from  $w_1$  to  $w_2$  takes place with the Internal/External switch (16) (at  $CB = 1$ ). The active setpoint is always shown on the analog bargraph display (2). At  $S81 = 0/1/5$  only the active setpoint can be shown on the digital display.

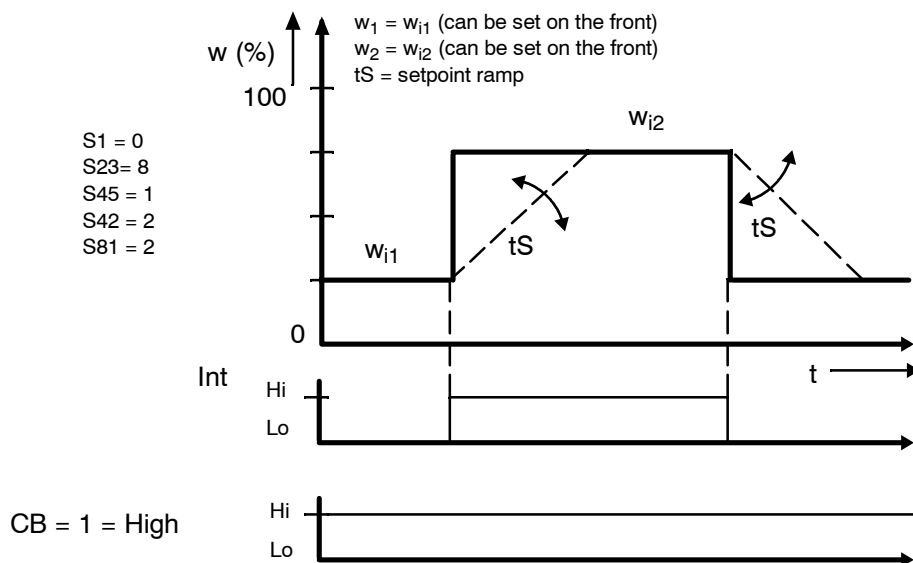

Figure 7-1 Setpoint curve according to example 1

**Example 2**

Three-setpoint operation with a slave controller  
 (see chapter 3.4.3, page 62)

- $w_E$  is an external variable setpoint
- SH safety setpoint fixed by parameterization in oFPA
- $w_i$  is an internal setpoint which can be adjusted on the front

The switching between  $w_E$  and SH takes place with the digital signal CB (Internal/External key (16) must be set to "External"). The External/Internal key (16) switches between  $w_E$ /SH and  $w_i$ . Figure 7-2 shows the setpoint curve with and without setpoint ramp tS.

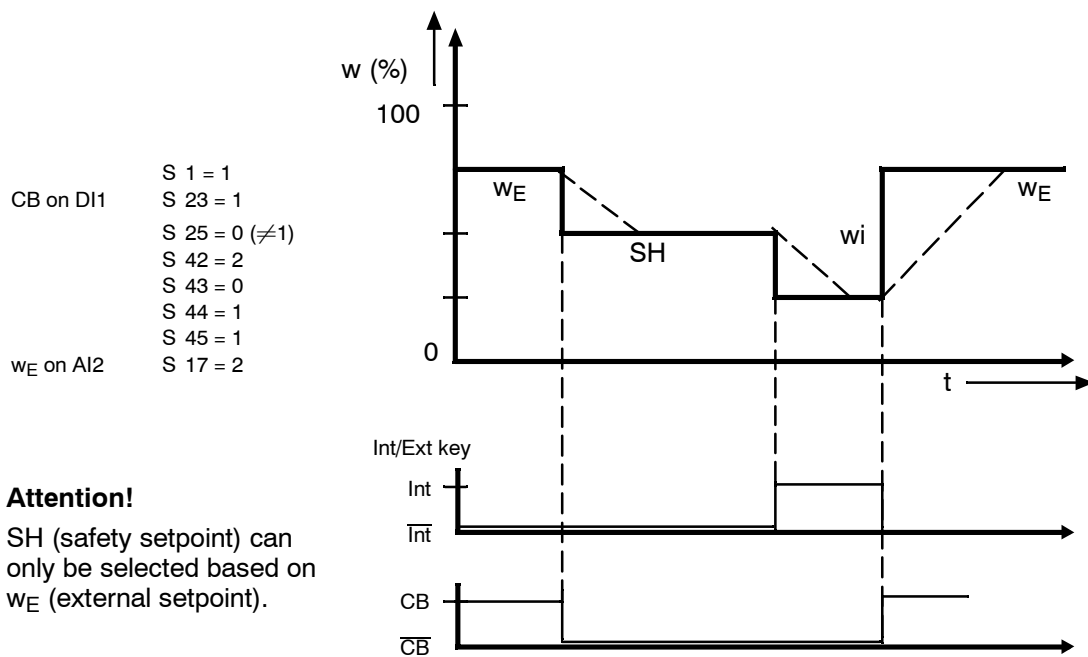

**Attention!**  
 SH (safety setpoint) can only be selected based on  $w_E$  (external setpoint).

Figure 7-2 Setpoint curve according to example 2

**Example 3**

Four-setpoint operation with one slave controller with Internal/  
External switching and CB signal through the digital input

The analog input AI2/w<sub>E</sub> is overcontrolled to 0 or 100%:

- w<sub>i</sub> setpoint which can be adjusted on the front
- w<sub>E</sub> setpoint limit fixed by parameterization of FPA (setpoint limit start SA), w<sub>E</sub> overcontrolled to 0 %.
- SH safety setpoint set by parameterization.
- w<sub>E</sub> setpoint limit fixed by parameterization of FPA (setpoint limit end SE)  
w<sub>E</sub> overcontrolled to 100 %.

Switchings take place:

- w<sub>i</sub>= key (16) to Internal
- w<sub>E</sub>= key (16) to External ( $\overline{\text{INT}}$ ), CB signal High (CB). AI2 overcontrolled to 0% (SA)
- SH= key (16) to External, CB from High to Low (CB)
- w<sub>E</sub>= key (16) to External ( $\overline{\text{INT}}$ ), CB signal High (CB). AI2 overcontrolled to 100% (SE)

Restriction of this circuit w<sub>i</sub> and SH must be within the limits SA to SE.

Also only the active setpoint can be displayed at S81 = 2/3. SH can only be reached by the transition  $\overline{\text{INT}} \wedge \text{CB}$  to  $\overline{\text{INT}} \wedge \overline{\text{CB}}$ .

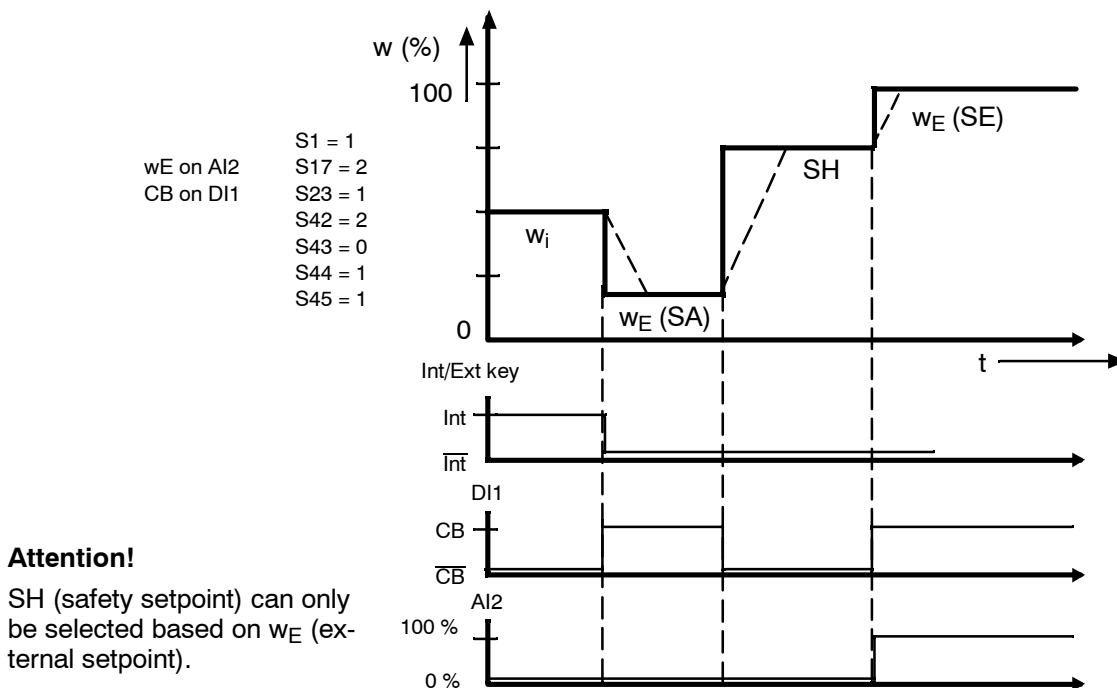

Figure 7-3 Setpoint curve according to example 3

**Example 4**

Fixed setpoint controller with setpoint ramp ( $t_s > 0$ )

Operation with an adjustable setpoint  $w_i$ , with  $x$  tracking by  $S_i$  (safety manipulated variable  $y_S$ ).

Due to  $x$  tracking the active setpoint follows the controlled variable  $x$  without a delay at  $S_i=1$  (DI for safety manipulated variable). If  $S_i$  becomes 0 the setpoint returns to the setpoint  $w_{i\text{set}}$  earlier with the setpoint ramp set as a time parameter. The setpoint ramp is not effective in  $x$  tracking.

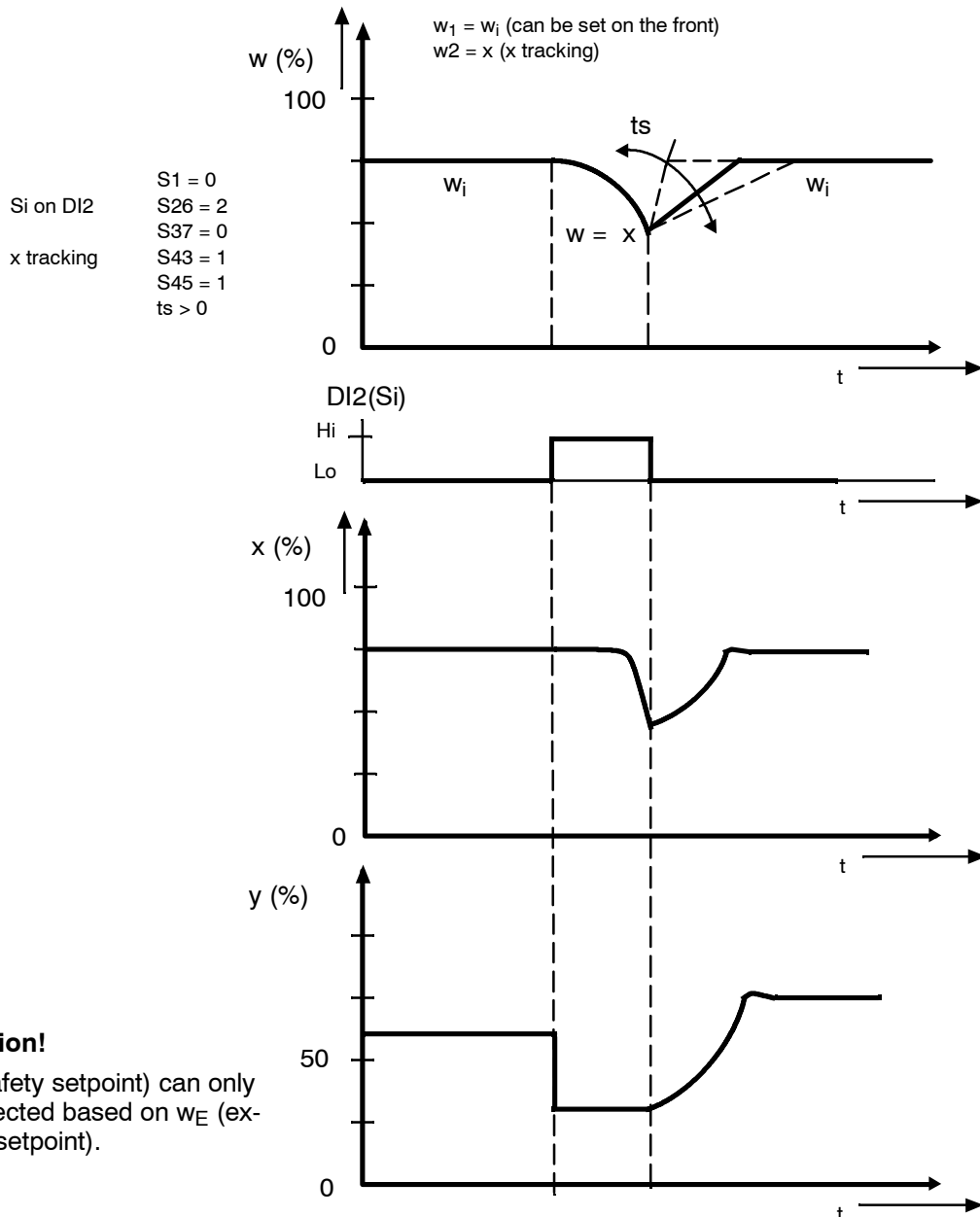

**Attention!**  
 SH (safety setpoint) can only be selected based on  $w_E$  (external setpoint).

Figure 7-4 Setpoint curve according to example 4

### 7.3 Configuration examples

#### Configuration example K1

Fixed setpoint controller as a K-controller  
Controlled variable by a four-wire transmitter

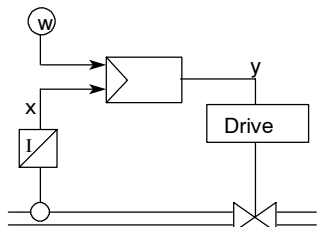

The controlled variable  $x$  from the transmitter goes to the analog input AI1 of the controller.

The input signal range is 0 to 20 mA.

The manipulated variable is also 0 to 20 mA.

Transmitter with  $U_H = 24\text{ V}$ :

The transmitter can also be fed from the controller (+ at terminal 9 and - at terminal 11).

Please read the foreword to chapter 7.1, page 193

Setting the structure switches:

- S1 = 0
- S2 = 0
- S4 = 0, 1
- S56 = 0

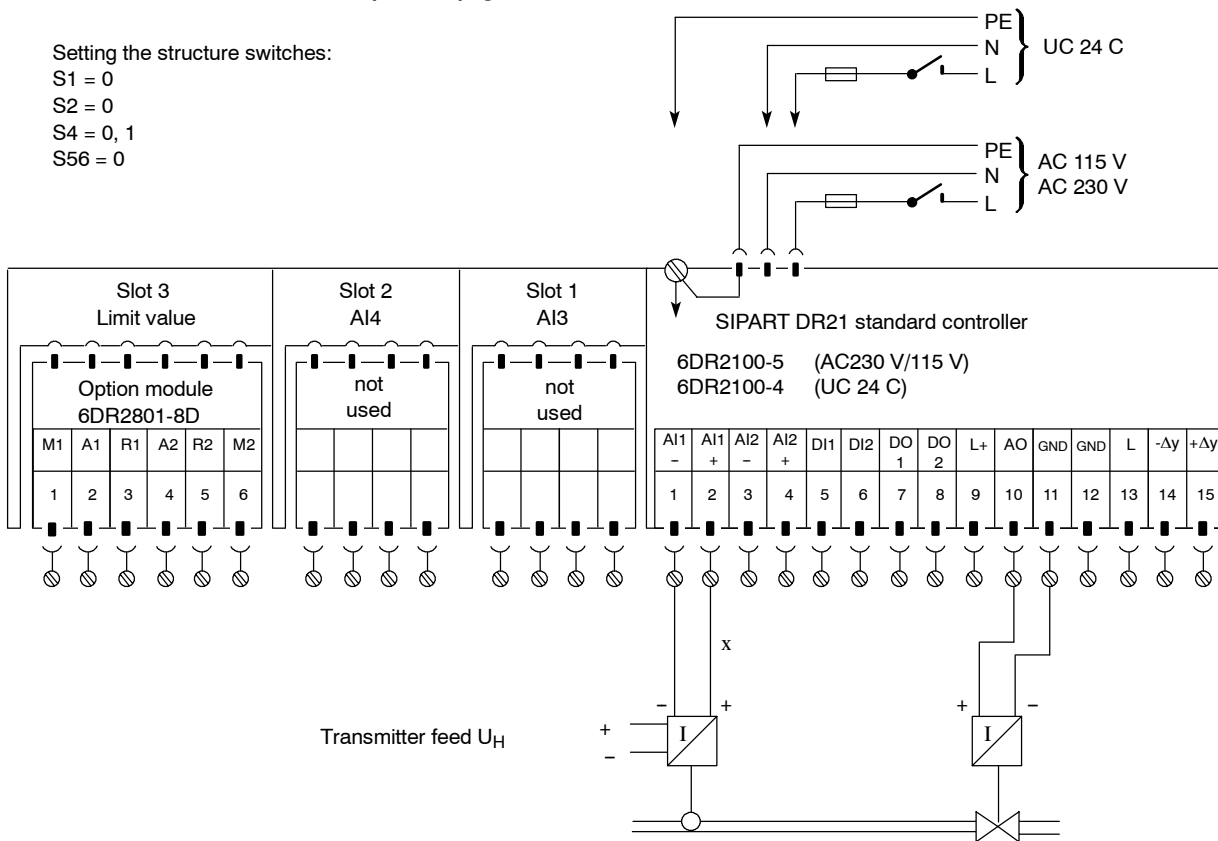

## Configuration example K2

Two common mode controllers as K-controllers; external setpoint from a two-wire transmitter with external feeding; Controlled variables from two-wire transmitters, feeding from the SIPART DR21 controller

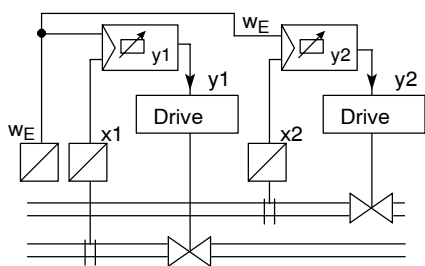

The external setpoint is looped serially through both controllers. Since the analog inputs AI1, AI2 of the controller are referenced to ground, the options module must be used for the current input in one of the controllers because this can process the appropriate common mode voltage. The setpoint  $w_E$  is evaluated differently in the two controllers in this example. As a result the controlled variables  $x_1, x_2$  have a constant relationship with each other. The external common setpoint can be evaluated with the online parameters  $c_4, c_5$ .

$$w_E = c_4 \cdot w_E + c_5$$

If the factory setting is left in controller 1  $c_4 = 1, c_5 = 0$ , the values for  $c_4, c_5$  of controller 2 in the controlled state gives the relationship between the controlled variables  $x_1, x_2$ .

$$x_1 = \frac{x_2 - c_5}{c_4}$$

Please read the foreword to chapter 7.1, page 193

### Controller 1

Setting the structure switches controller 1:

S1 = 1

S2 = 0

S15 = 1

S17 = 3

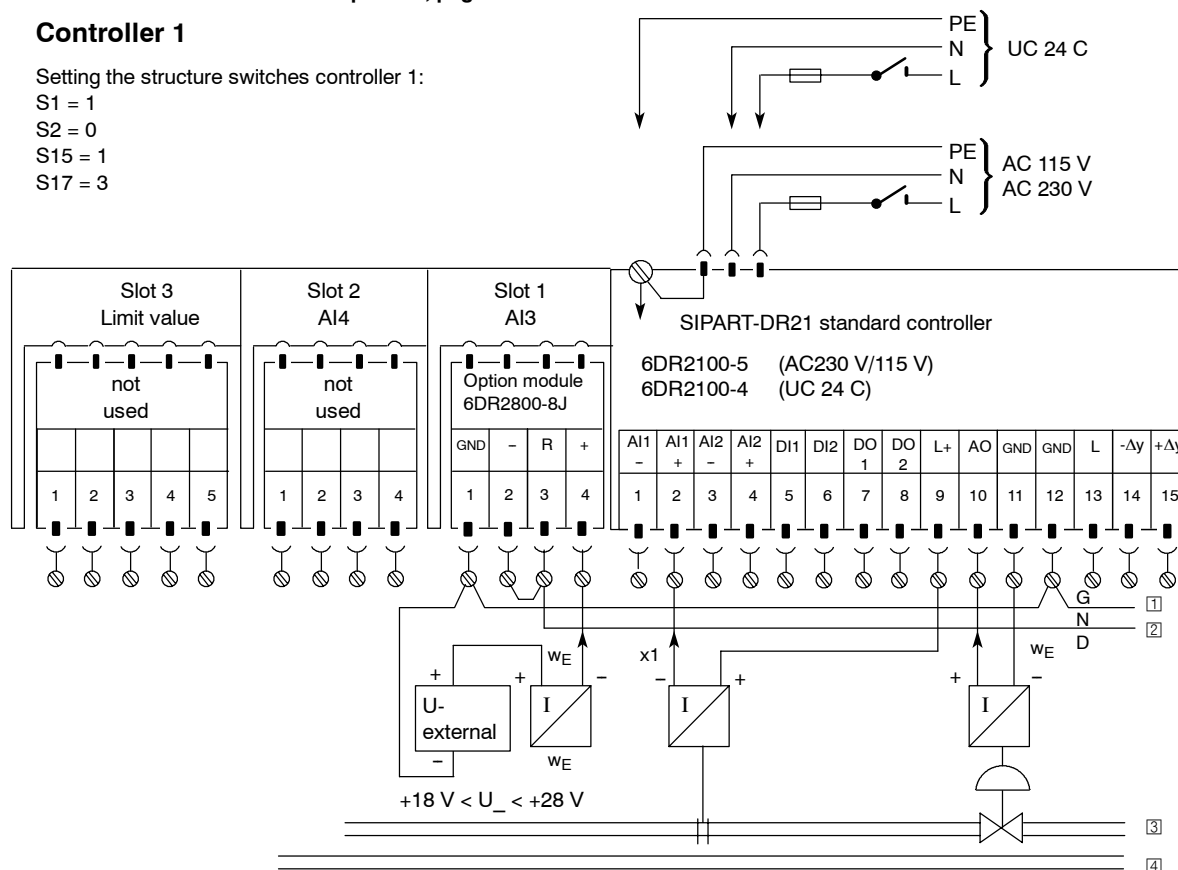



**Configuration example K2** continued

**Controller 2**

Setting the structure switches controller 2:

- S1 = 1
- S2 = 0
- S15 = 1
- S16 = 0
- S17 = 2

Set online parameters c4, c5

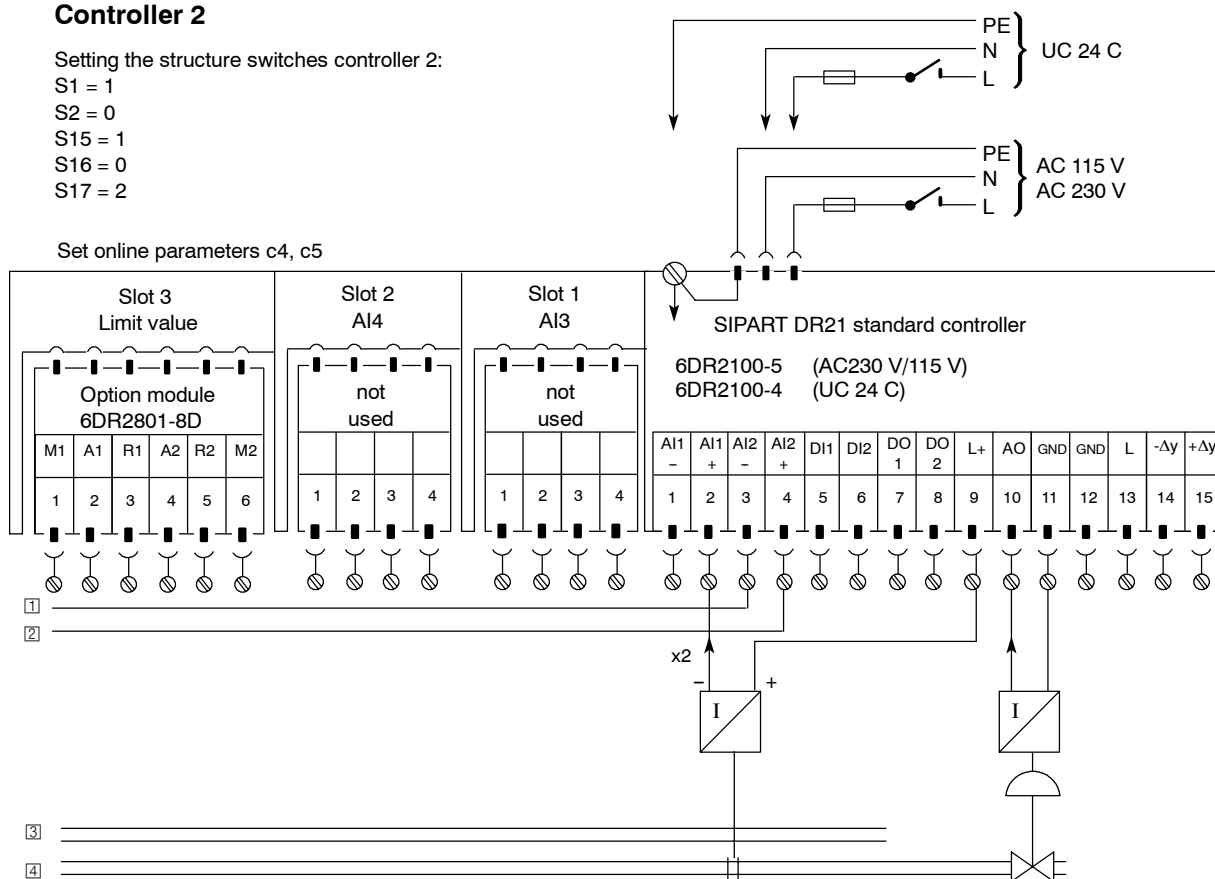

### Configuration example K3

Fixed setpoint controller as a K-controller  
 Controlled variable by a two-wire transmitter

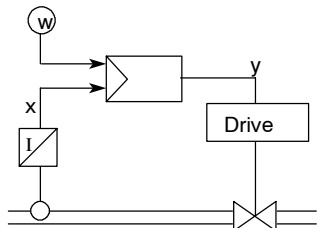

The controlled variable  $x$  from the transmitter goes to the analog input AI1 of the controller.  
 The transmitter is fed by the same lines. The input signal range and the output manipulated variable of the controller are 4 to 20 mA.

Please read the foreword to chapter 7.1, page 193

Setting the structure switches:

- S1 = 0
- S2 = 0
- S4 = 2, 3
- S56 = 1

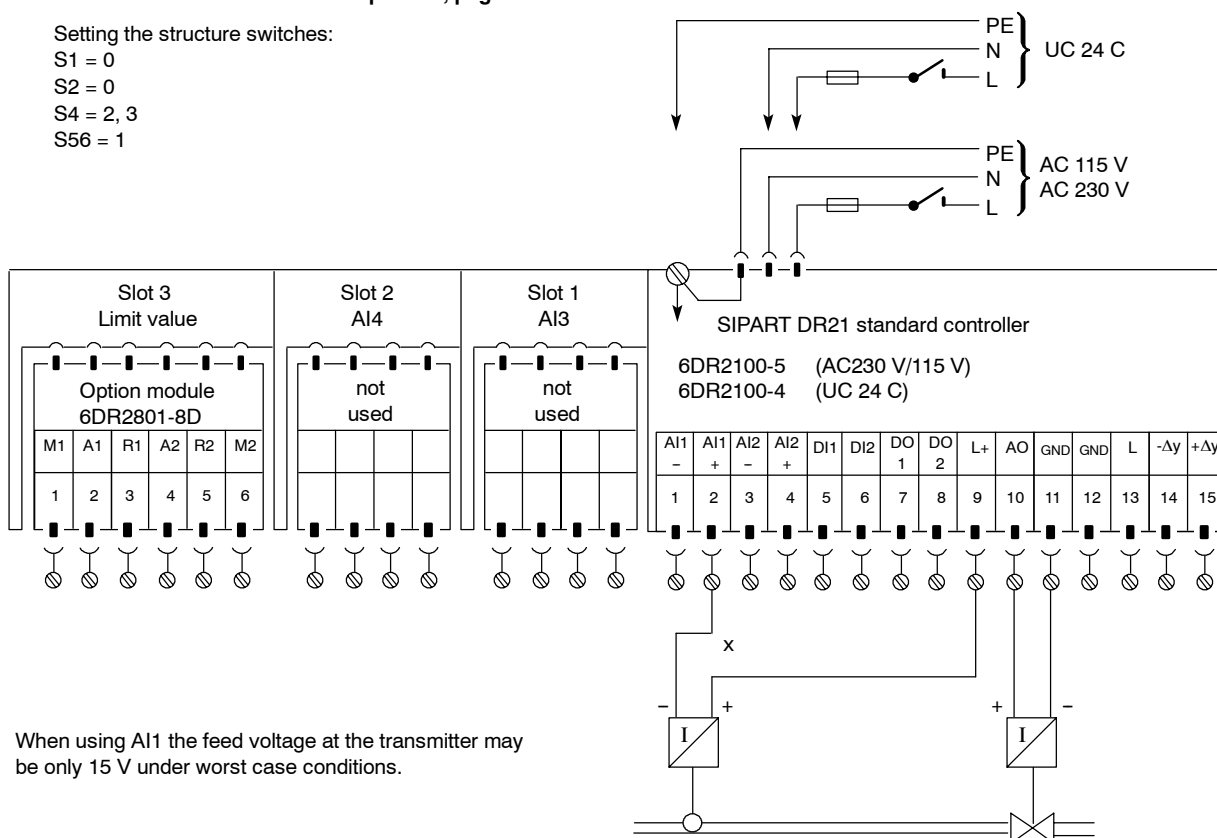

When using AI1 the feed voltage at the transmitter may be only 15 V under worst case conditions.

### Configuration example S1

Slave control, three-position step controller with internal feedback;  
Controlled variable by a two-wire transmitter, externally fed  
position feedback via an ESR;  
External setpoint potentiometer

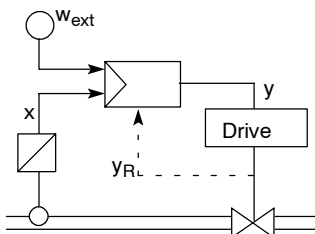

The controlled variable of the transmitter goes to the analog input AI1, the position feedback of ESR to the analog input AI2 of the controller. A signal range of 0 to 20 mA is programmed for both inputs.

Transmitter and ESR are externally fed.

A cascade is disconnected preferably by switching the master controller to manual mode. The slave controller is still in automatic mode, its setpoint is still the output signal of the master controller, i.e. now its manual manipulated variable. The slave controller therefore becomes the fixed setpoint controller. Switching back the master controller to automatic mode and thus the interconnection of the cascade takes place bumplessly but not without drift if the setpoint of the slave controller but not that of the master controller was adjusted during switching.

The drifting after switching back can be prevented if the master controller is programmed with structure switch S43 = 1 to x tracking. Then the setpoint of the master controller is tracked to the actual value which changes with the delay time of the system as long as the cascade is disconnected.

Please read the foreword in chapter 7.1, page 193 and the warnings in chapter 2.1 (from page 17)

Setting the structure switches:

- S1 = 1            S19 = 2
- S2 = 2            S42 = 1
- S17 = 4           S54 = 1

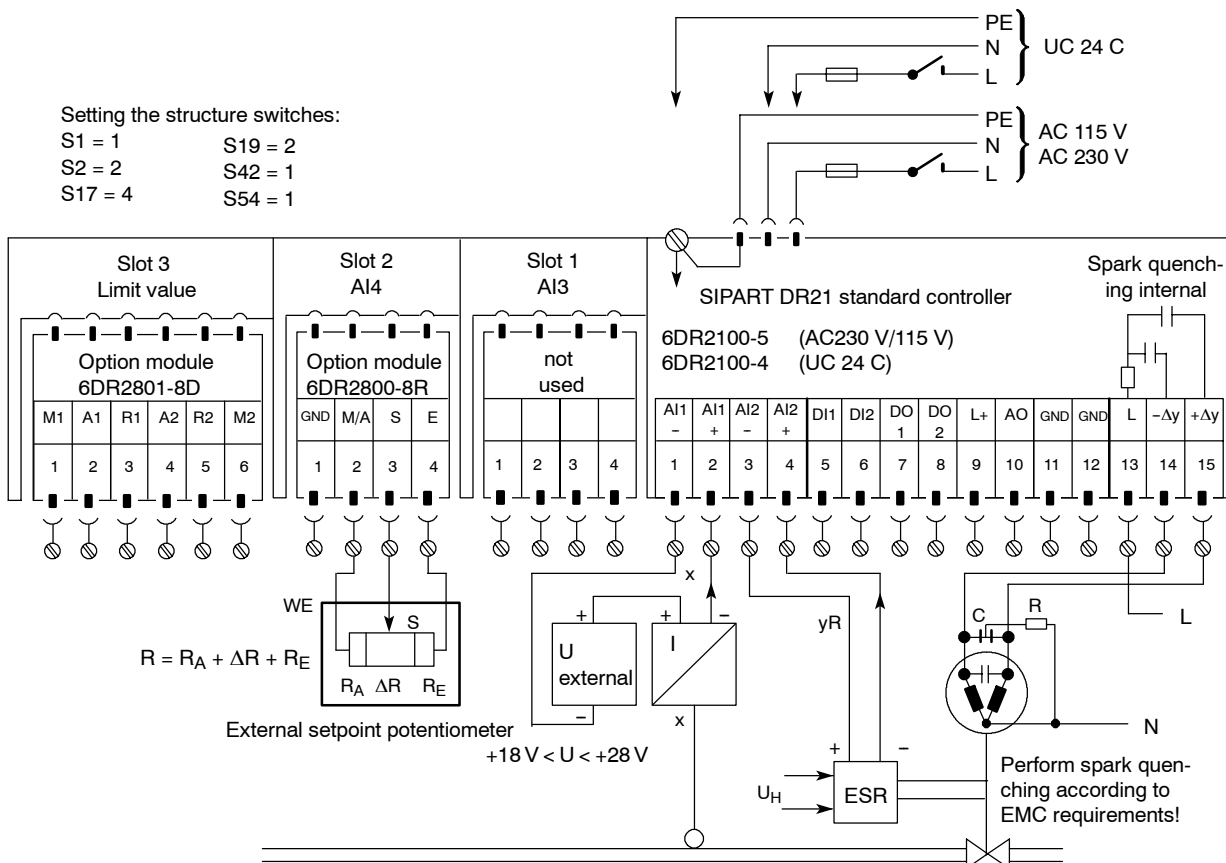

**Configuration example S2** cascade control, K-controller and S-controller (internal feedback);  
 The controlled variables of the master controller and the slave controller come directly from the resistance thermometers Pt100.

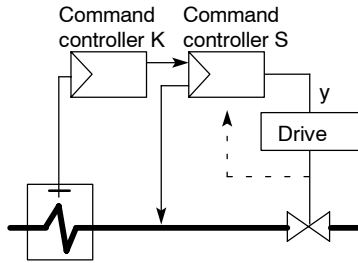

The master controller is a SIPART DR21 with K-output, the slave controller has one three-position step output.  
 The controlled variables of both the master controller and slave controller come directly from the resistance thermometers Pt100 and are connected at the analog input AI3 in both controllers. The position feedback of the step switching slave controller comes from a potentiometer, connected at the analog input AI4. The output signal of the master controller is the setpoint for the slave controller and is fed to its analog input AI1.

Please read the foreword in chapter 7.1, page 193 and the warnings in chapter 2.1 (from page 17)

**Master controller**

Setting the structure switches of the master controller:

- S1 = 0                      S8 = 4
- S2 = 0                      S15 = 3
- S6 = 4 to 7                S17 = 0

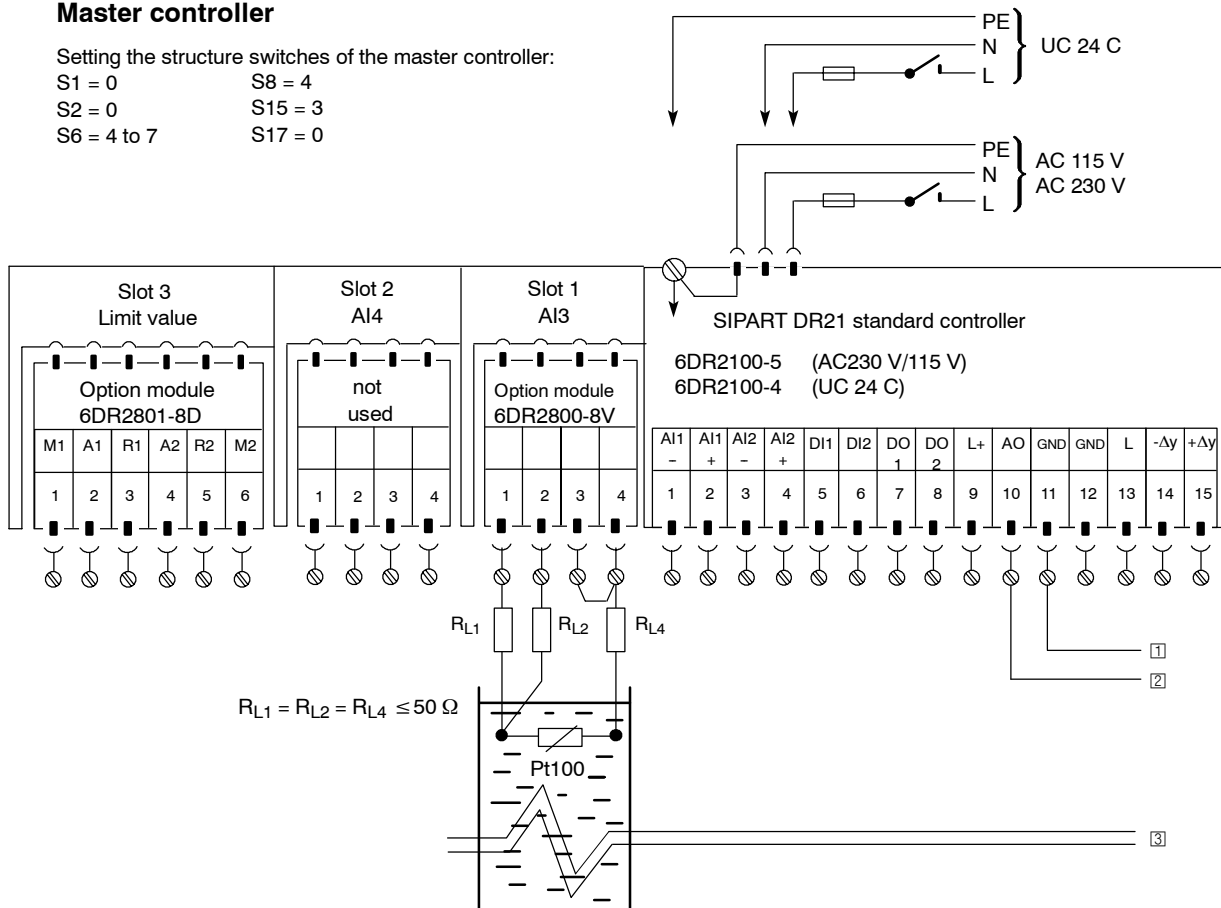

**Configuration example S2** continued

**Slave controller**

Setting the structure switches of the follow-up controller:

- S1 = 1                      S8 = 4                      S54 = 1
- S2 = 3                      S15 = 3
- S6 = 4 to 7                S17 = 1
- S7 = 0, 1                  S42 = 1, 2

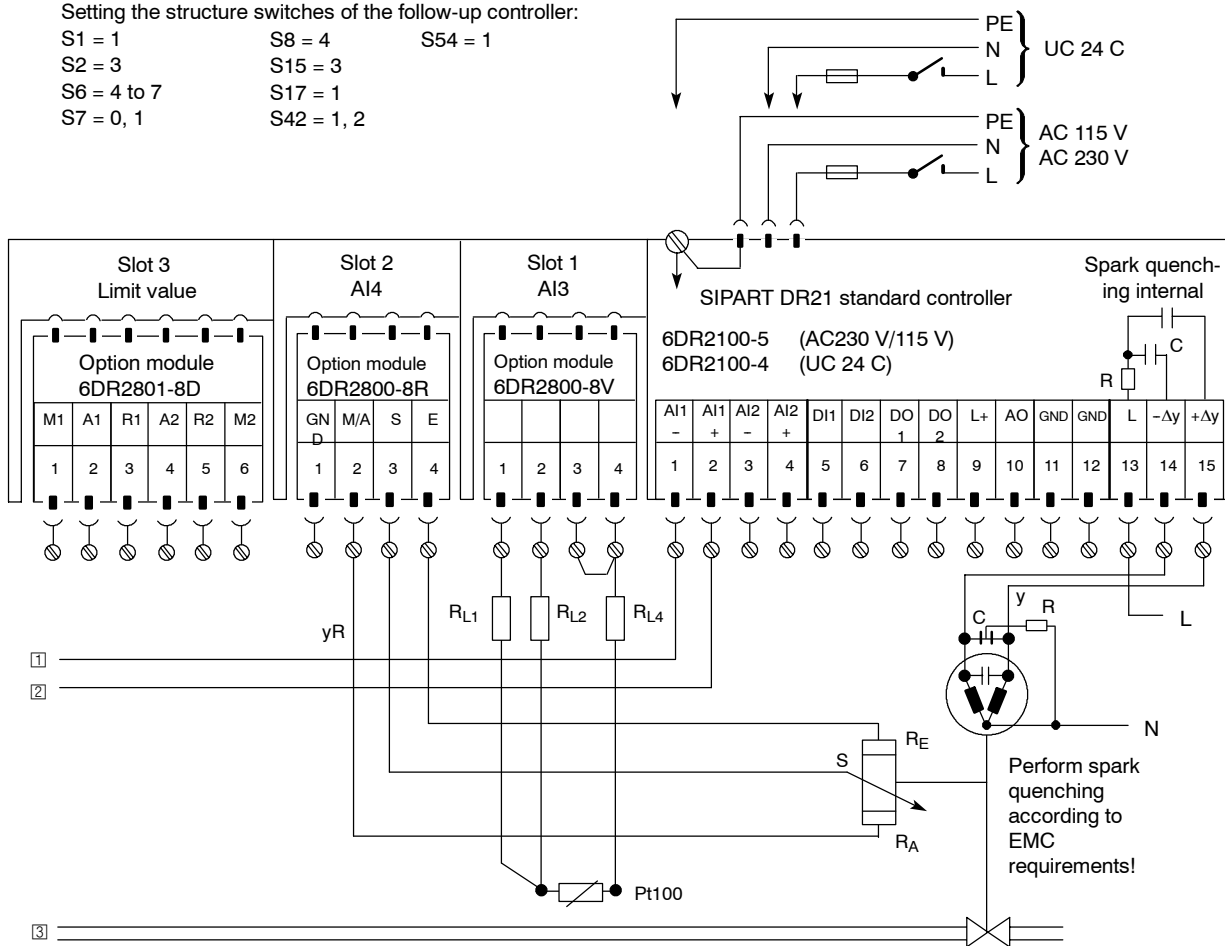

### Configuration example S3

Ratio control, S-controller (internal feedback)

Commanded process variable and commanding variable directly from two-wire transmitters

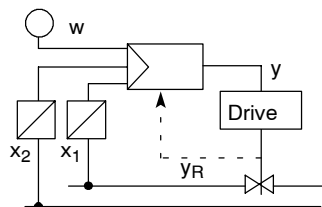

The commanded process variable  $x_1$  from the transmitter goes to the analog input AI1, the commanding process variable is connected to the analog input AI2. The input signal ranges are 4 to 20 mA. The feedback of the final control element position comes from a resistance potentiometer to the analog input AI4. The setting of the ratio factor range is described in chapter 3.4.5, page 75.

Please read the foreword in chapter 7.1, pg. 193 and the warnings in chapter 2.1 (from page 17)

Setting the structure switches:

- S1 = 3                      S5 = 2, 3
- S2 = 2                      S7 = 0, 1
- S4 = 2, 3                    S54 = 1

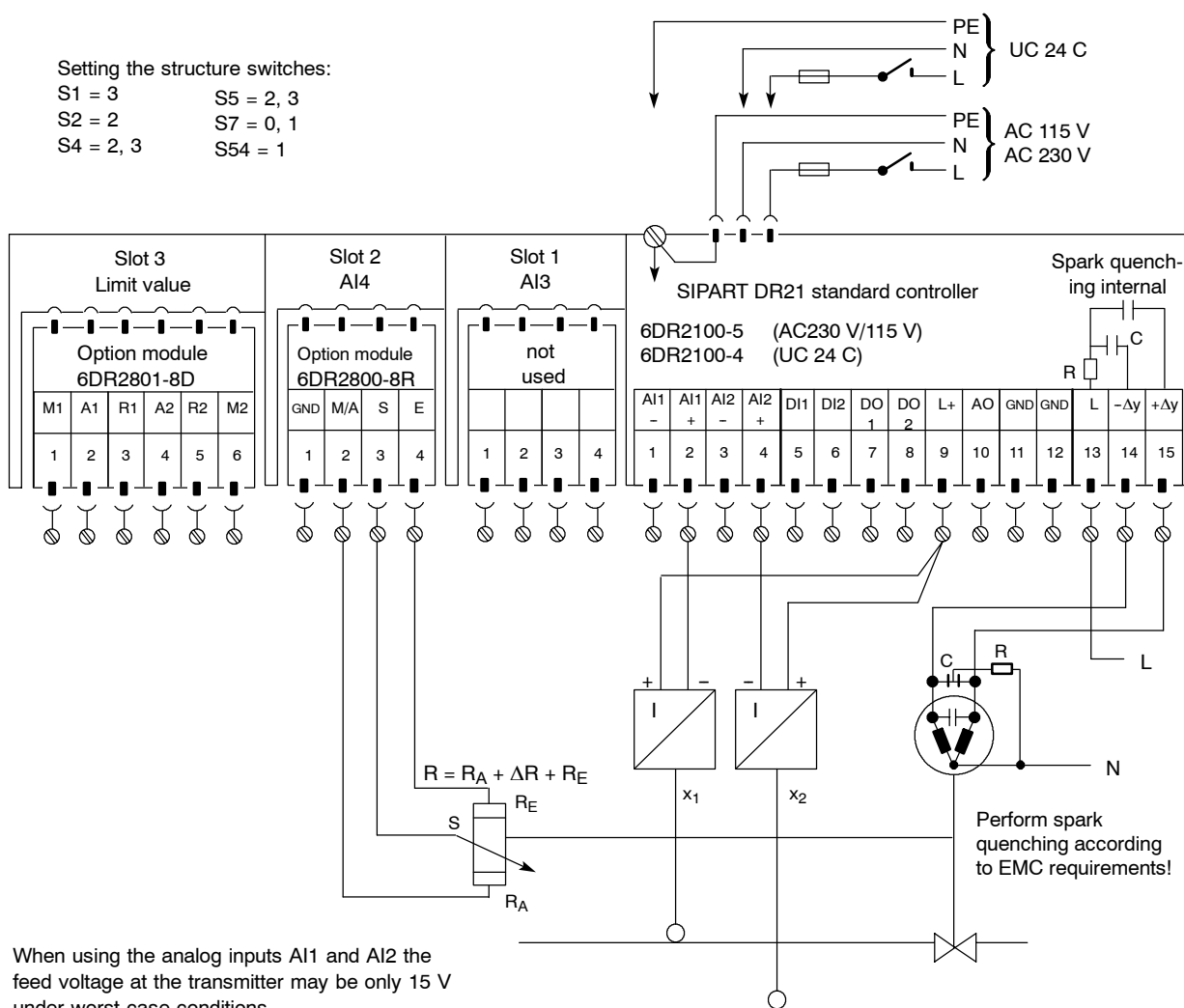

When using the analog inputs AI1 and AI2 the feed voltage at the transmitter may be only 15 V under worst case conditions.

### Configuration example Z1

Fixed setpoint control with PD two-position controller

The controlled variable comes from a thermocouple with internal reference point.

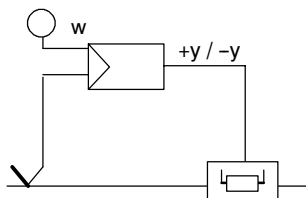

The controlled variable of the thermocouple is fed directly to the analog input AI3. The type of thermocouple is selected with S9. The measuring range must be set in the CAE menu (see chapter 5.4.5, page 165).

System adaptation with the parameters Y1 and Y2.

Two-position controller structure see chapter 3.6, page 94

Please note the possibilities of setting the operating point in the P-controller (page 93) and the foreword in chapter 7.1, page 193

Setting the structure switches:

- S2 = 1            S15 = 3
- S6 = 4 to 7      S27 = 8
- S8 = 1            S54 = 3

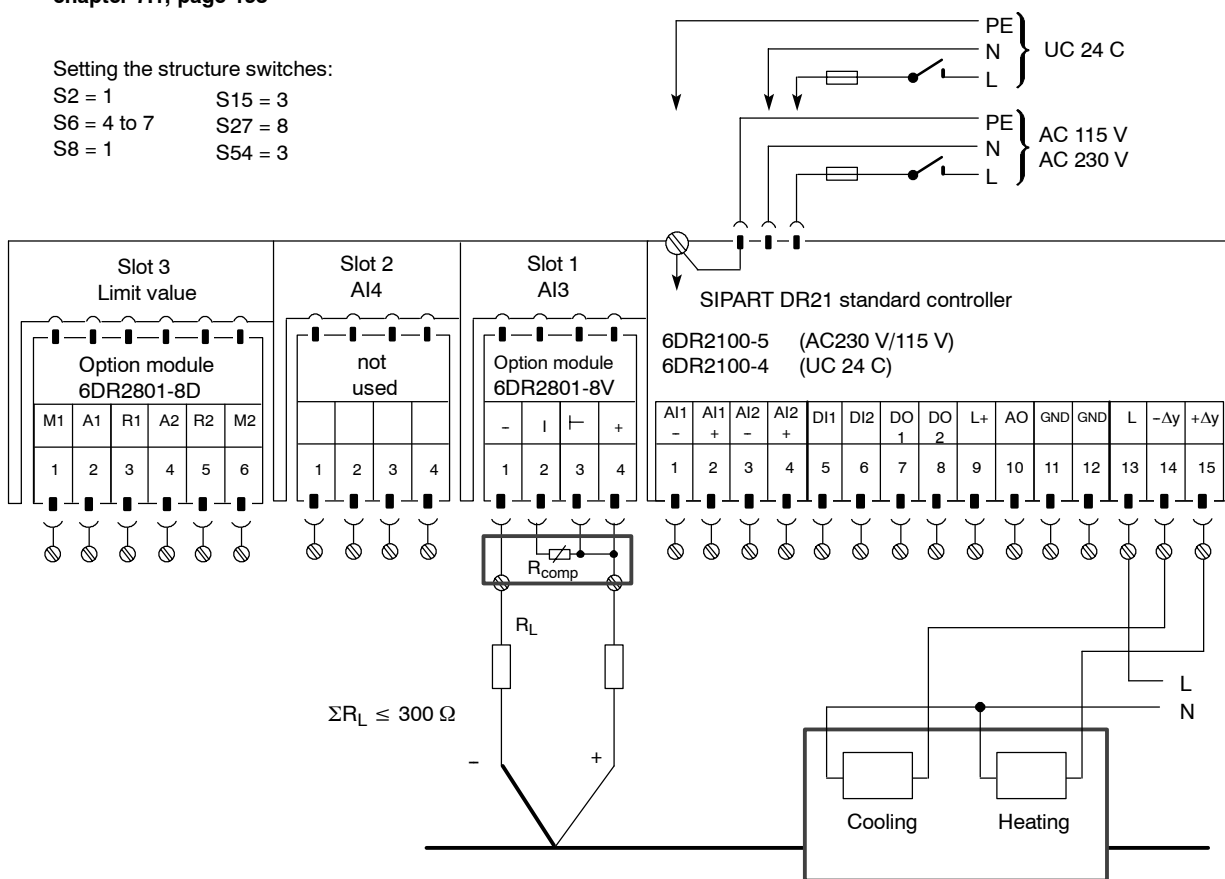

## Configuration example L1 Process display

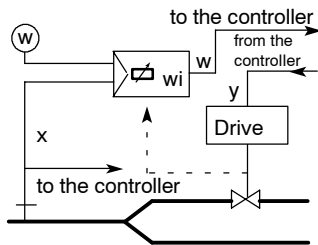

Structured as a process display, the SIPART DR21 controller can display and monitor the process variables. If the manipulated variable  $y$  and  $yR$  is structured, it can be monitored to the  $y$  display and can be adjusted with the keys (7) and (8) with the appropriate wiring. The controlled variable  $x$  can be shown in the red analog display (1) with structuring as  $x2$ . If the limit value  $A1$  to  $A4$  if referred to  $x$  with  $S76$ ,  $S77$ ,  $S80$  and shown in the green bar display (2), the relation of the variable to be monitored to the limit values can be seen at a glance. With the parameters  $dA$ ,  $dE$  (oFPA) the variables  $w$ ,  $x$ ,  $A1$  to  $A4$  can be displayed in their right physical variable in the  $w/x$  display (3). The  $y$  display is made in 0 to 100%. See also fig. 3-16, page 82

Please read the foreword to chapter 7.1, page 193

Setting the structure switches of the process display:

- |  |                                |
|--|--------------------------------|
| S1 = 4, process display  | S42 = 2, w: int ↔ ext          |
| S2 = 2, S-controller internal feedback   | S54 = 1, yR display            |
| S15 = 0, x1 = 0  | S56 = 2, w → AO                |
| S16 = 3, x2 → AI3  | S57 = 1, ±Δy → DO1/2           |
| S17 = 1, we → AI1  | S76 = 2, A1/A2 } referred to x |
| S19 = 2, yR → AI2  | S77 = 2, A3/A4 }               |
| S80 = 6, Alarms A1 to A4 in the process operation mode can be displayed and adjusted |                                |

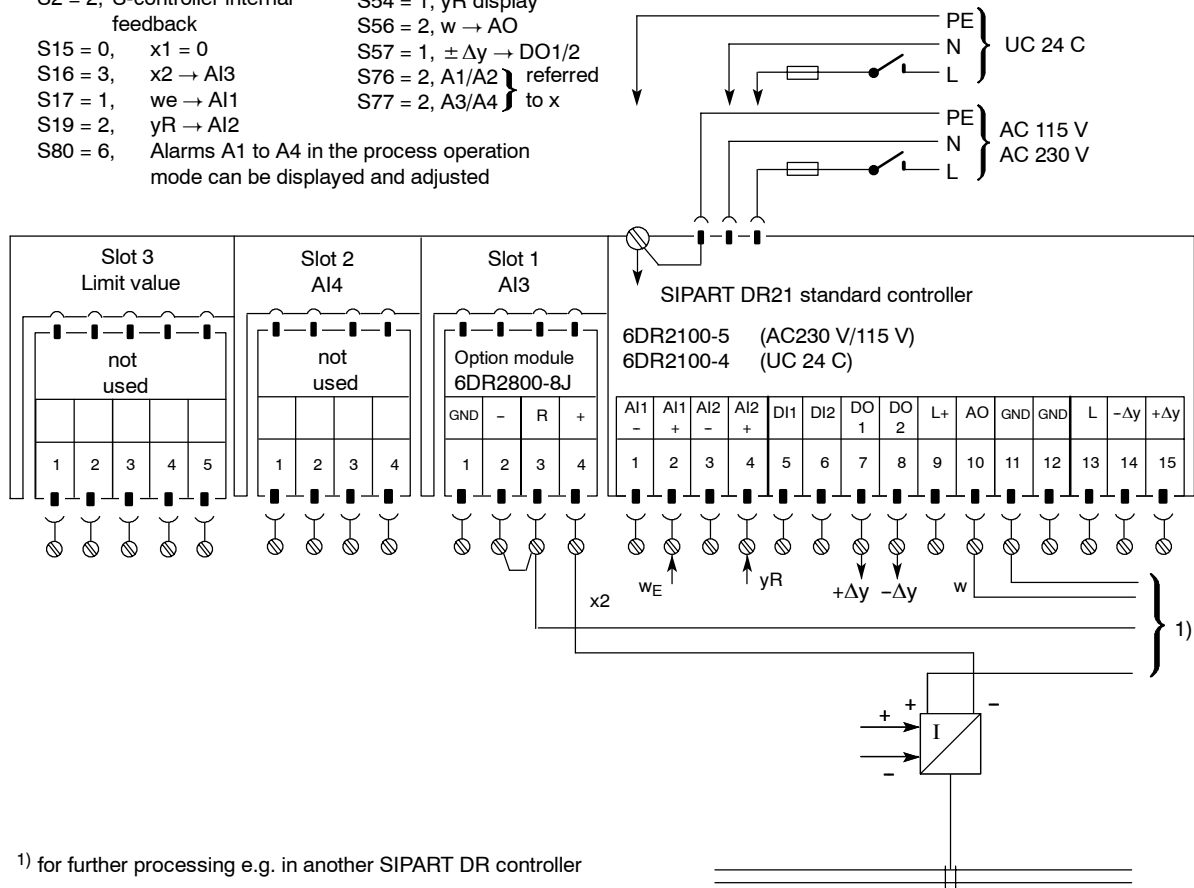

1) for further processing e.g. in another SIPART DR controller



**Configuration example L1 process display (continued)**

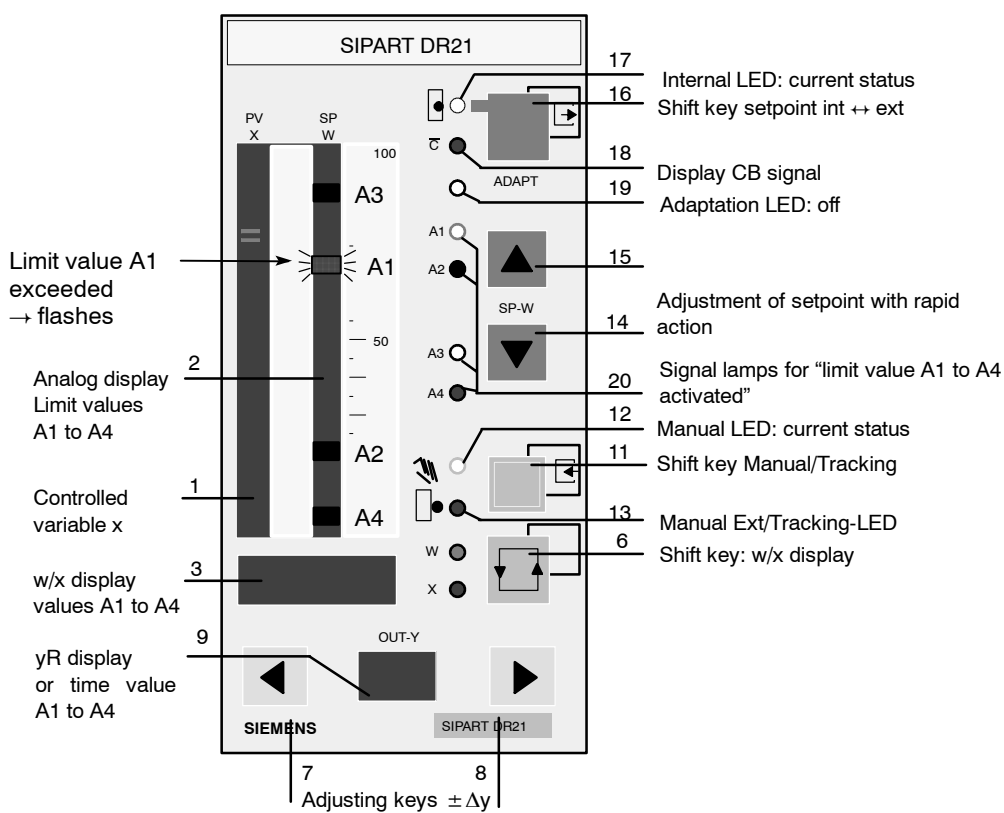

Process operation mode – control and display elements in the setting as a process display

## Configuration example L2 Manual control unit (HS)

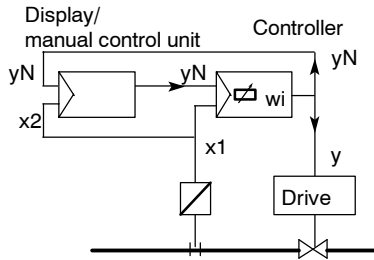

The "Manual control unit" operating mode is implemented in the setting S1 = 4 (control unit/process display). The output of a K-controller (e.g. another SIPART DR21) can be remote controlled with the HS.

The manual control unit has priority over the controller. In the HS manual operation has priority over tracking, in the controller tracking over manual operation. The HS is tracked if it is not in manual operation itself, i.e. if LED (13) H external lights and LED (12) Manual is dark. The controller is always tracked when the HS is in manual operation, i.e. if the LED (12) on the HS is alight. If LED (12) H flashes on the controller, this means that manual operation is not possible from the controller because tracking from the HS has priority. LEDd (13) on the controller lights up.

Please read the foreword to chapter 7.1, page 193

### Manual control unit

Setting the structure switches of the manual control unit:

S1 = 4, control unit      S18 = 2, yN ↔ AI2  
 S2 = 0, K-controller    S23 = 0, CB = 0  
 S15 = 0, x1 = 0        S49 = 1  
 S16 = 1, x2 → AI1      S60 = 1, H → DO1

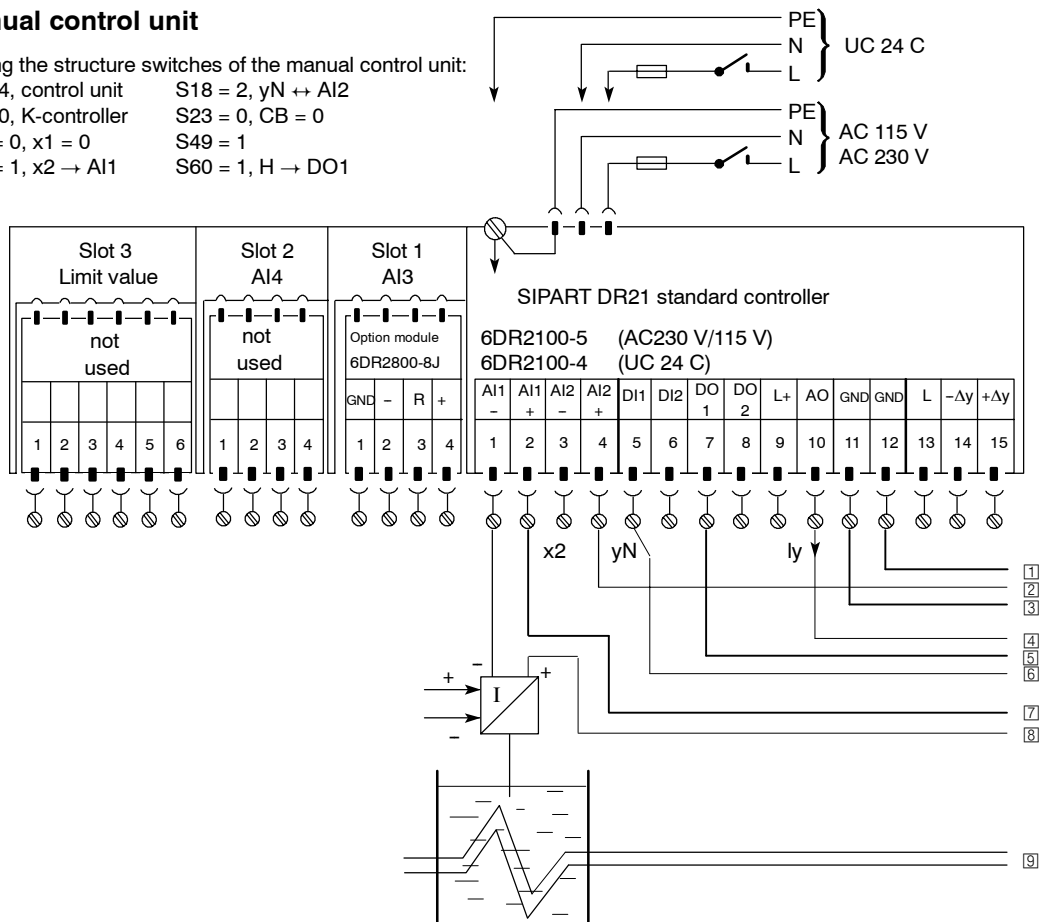

## Configuration example L2 Manual control unit (HS) (continued)

The process variables controlled variable and manipulated variable can be displayed online on the HS. The setpoint can only be simulated as a flag, i.e. it must be transmitted manually by the controller. For this, CB must be = 0 (S23 = 0) on the HS. See also chapter 3.4.6, page 80 and figure 3-18, page 87.

### K-controller

Setting the structure switches of the K-controller:

- S1 = 0, fixed setpoint controller
- S2 = 0, K-controller
- S15 = 4, X1 → AI4
- S18 = 1, yN → AI1
- S61 = 1, Nw → DO1
- S72 = 1

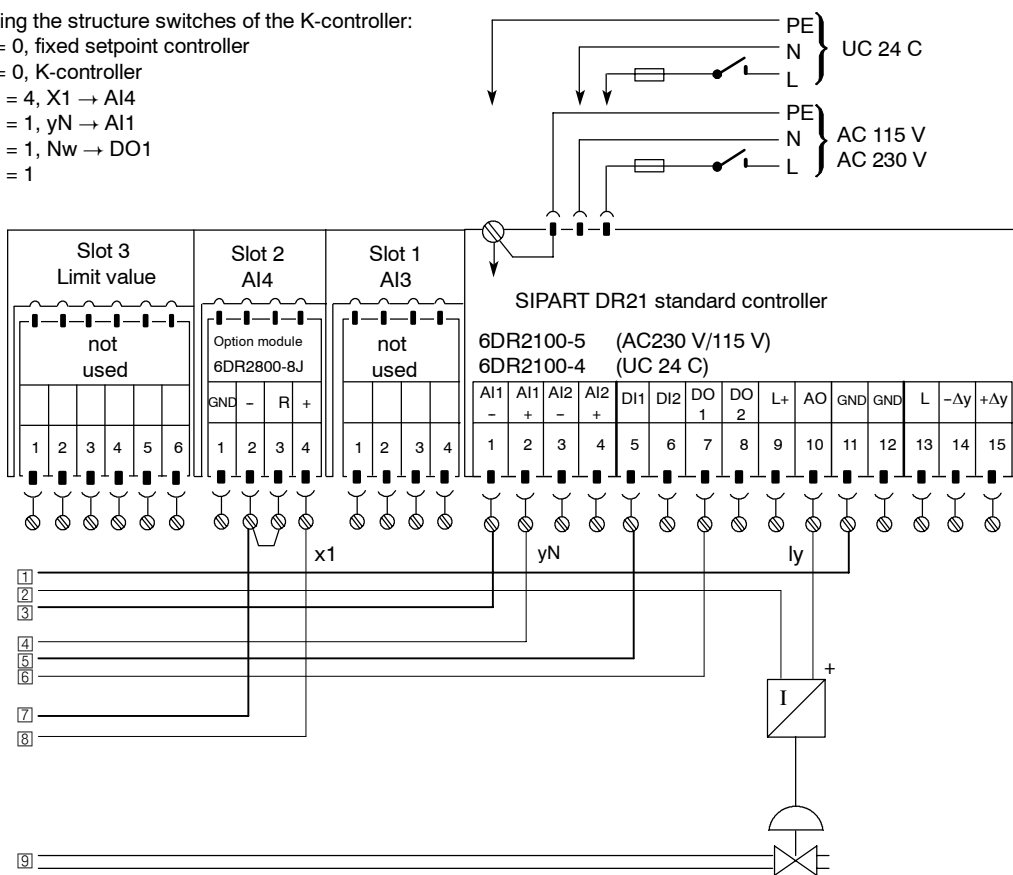

### Configuration example L3 control unit (LG) with slave controller (FR)

LG operates as a setpoint transmitter and manual control unit with S-output.

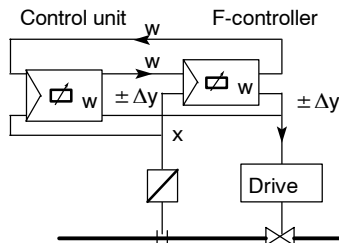

With the LG the setpoint and the S-output of the slave controller can be remote controlled. The FR has priority with respect to setpoint and manual operation. The setpoint of the FR can only be set with the LG when the LED (17) internal, LED (18) $\bar{c}$  and LED (4) w display are alight. It is recommended to switch off the setpoint ramp on the FR. Before switching over to setpoint presetting from the FR, you have to wait for the setpoint set on the LG (max. 6 s). Parallel to the FR, the process variables setpoint, controller variable and position variables setpoint, can be displayed on the LG. x2 must be structured with S16 on the LG for the analog x value display.

Please read the foreword to chapter 7.1, page 193

#### Control unit (LG)

- Setting the structure switches of the control unit:
- S1 = 4, control unit
  - S2 = 0, S-controller i.Rf.
  - S15 = 0, x1 = 0
  - S17 = 1, we → AI1
  - S19 = 3, yR → AI3
  - S22 = 1, Opt. Position 3
  - S23 = 1, CB → DI1
  - S25 = 0, N = 0
  - S26 = 0, Si = 0
  - S29 = 2, +yBL → DI2
  - S30 = 2, -yBL → DI2
  - S42 = 2, wi: int ↔ ext
  - S49 = 1
  - S54 = 1, yR display
  - S56 = 2, w → AO
  - S57 = 1, ±Δy → DO1/2
  - S58 = 3, RB → DO3
  - S60 = 4, H → DO4
  - S62 = 5, A1 → DO5
  - S63 = 6, A2 → DO6

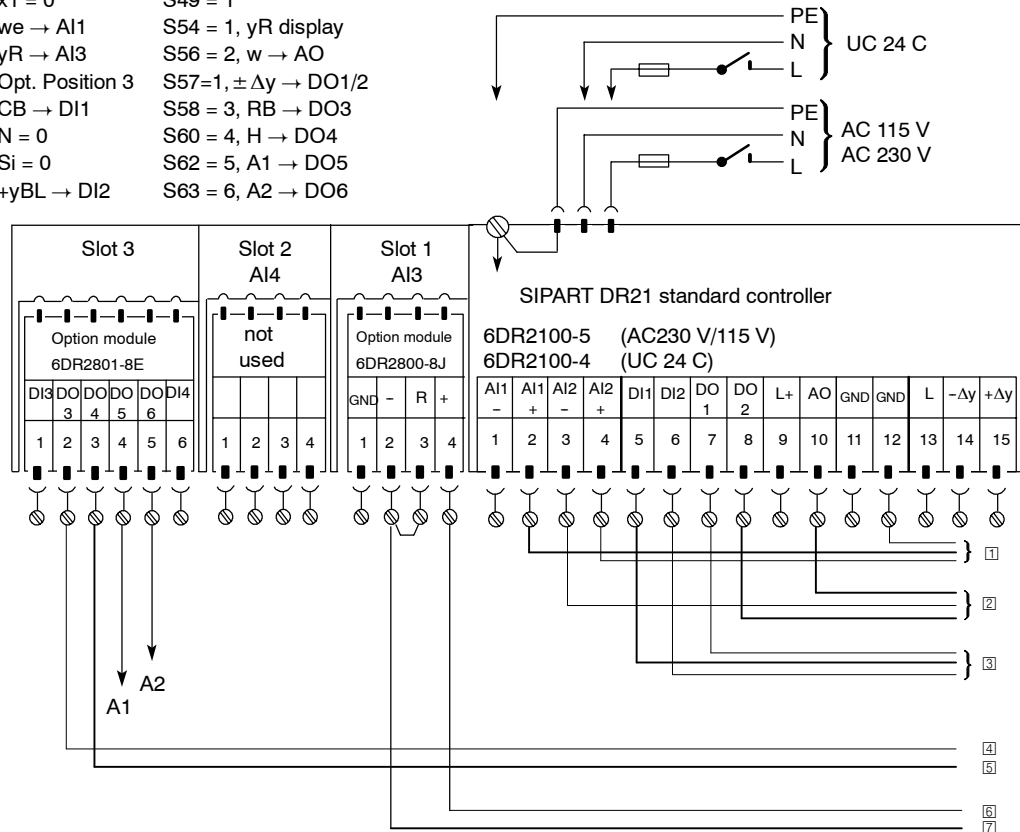

### Configuration example L3 Control unit (LG) with slave controller (FR) (continued)

Tracking of the internal setpoint  $w_i$  to the active setpoint ( $S_{45} = 0$ ) and the latter  $w_i$  as a setpoint at CB failure ( $S_{44} = 0$ ) must be set otherwise setpoint steps occur when switching between LG and FR.

Manual control of the manipulated variable from the LG is only possible if the LED (12) Manual on the LG lights up and the LED (13) H ext. is dark. Lighting of the LED (13) indicates manual operation of the FR. If the LED (12) of the FR is alight, manual operation is possible from there in any case. See also chapter 3.4.6, page 80 and figure 3-18, page 87.

#### Slave controller (FR)

Setting the structure switches of the follow-up controller:

- |  |   |
|--|---|
| S1 = 1, follow-up controller             | S49 = 1                                   |
| S2 = 2, S-controller i.Rf.               | S54 = 1, yR display                       |
| S15 = 3, $x_1 \rightarrow AI_3$          | S56 = 2, $w \rightarrow AO$               |
| S16 = 0, $x_2 \rightarrow 0$             | S57 = 1, $\pm \Delta y \rightarrow DO1/2$ |
| S17 = 1, $w_e \rightarrow AI_1$          | S58 = 3, RB $\rightarrow DO_3$            |
| S19 = 2, yR $\rightarrow AI_2$           | S60 = 4, H $\rightarrow DO_4$             |
| S22 = 1, Opt. Position 3                 | S62 = 5, A1 $\rightarrow DO_5$            |
| S23 = 2, CB $\rightarrow DI_2$           | S63 = 6, A2 $\rightarrow DO_6$            |
| S26 = 0, Si $\rightarrow 0$              |   |
| S42 = 2, $w_i$ int $\leftrightarrow$ ext |   |

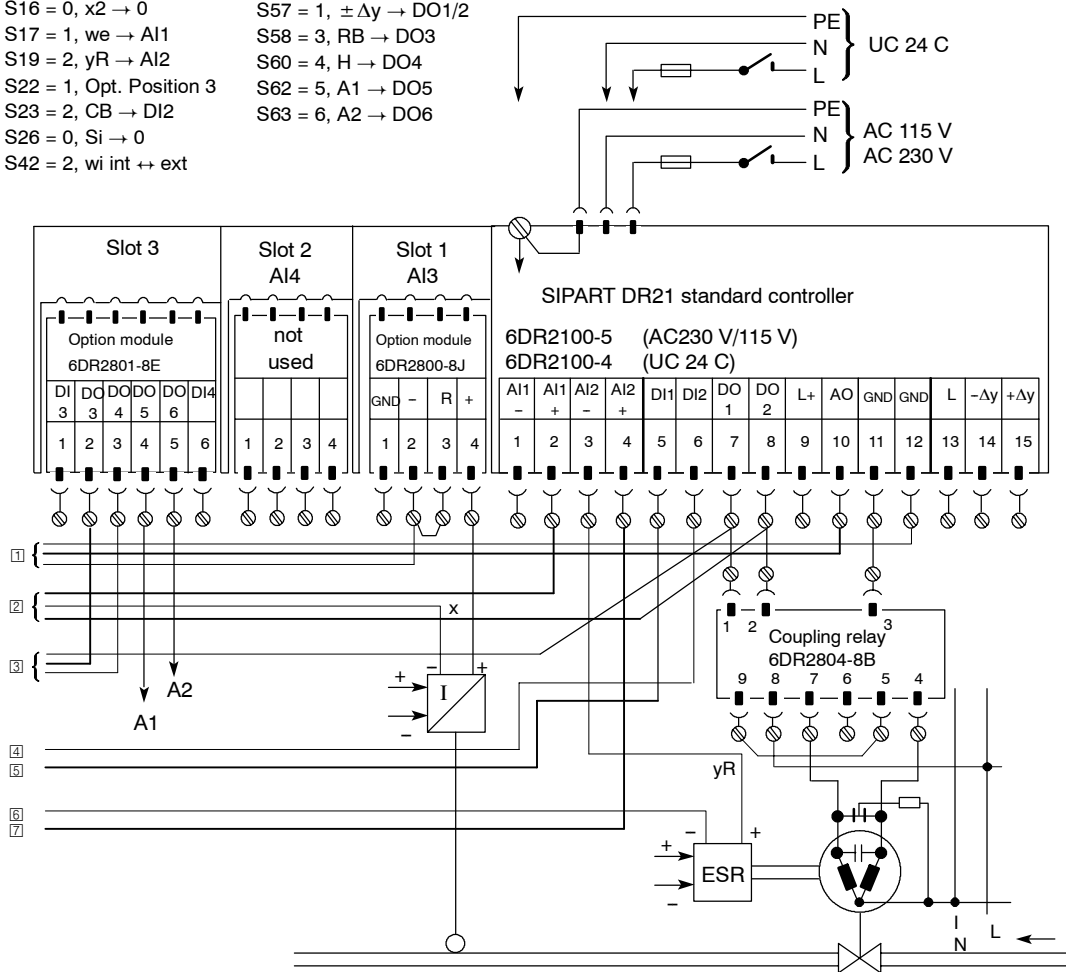

### Configuration example L4 control unit (LG) with slave controller (FR)

The control unit (SIPART DR21) operates as a setpoint transmitter and manual control unit, the slave controller (FR) SIPART DR22 as a K-controller

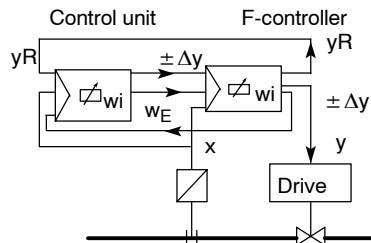

If the controller following the control unit is to operate as a K-controller, a SIPART DR22 must be used. In the SIPART DR22 an additional analog output is available for output of the setpoint and switching inputs for tracking the manipulated variable. In this example the control unit is structured as a K-setpoint transmitter and as an S-manual control unit. The controller has priority with respect to manual operation and internal setpoint presetting. The setpoint can only be preset by the LG and accepted by the FR if both LEDs Int/Ext (17) and  $\bar{C}$  (18) light up. In all other cases the value preset by the FR is only displayed in the LG. Manual operation of the LG is only possible when the Manual LED (12) lights steadily.

Please read the foreword to chapter 7.1, page 193

#### SIPART DR21 control unit

Setting the structure switches of the SIPART DR21 control unit:

- |                            |                       |
|----------------------------|-----------------------|
| S1 = 4, control unit       | S25 = 0, N → DI2      |
| S2 = 2, S-controller i.Rf. | S26 = 0, Si → 0       |
| S15 = 0, x1 → 0            | S42 = 2, wi int ↔ ext |
| S17 = 1, we → AI1          | S54 = 1, yR display   |
| S19 = 3, yR → AI3          | S56 = 2, w → AO       |
| S22 = 1, Opt. Position 3   | S57 = 1, ±Δy → DO1/2  |
| S23 = 21, CB → DI1         | S58 = 4, RB → DO4     |
|                            | S60 = 3, H → DO3      |

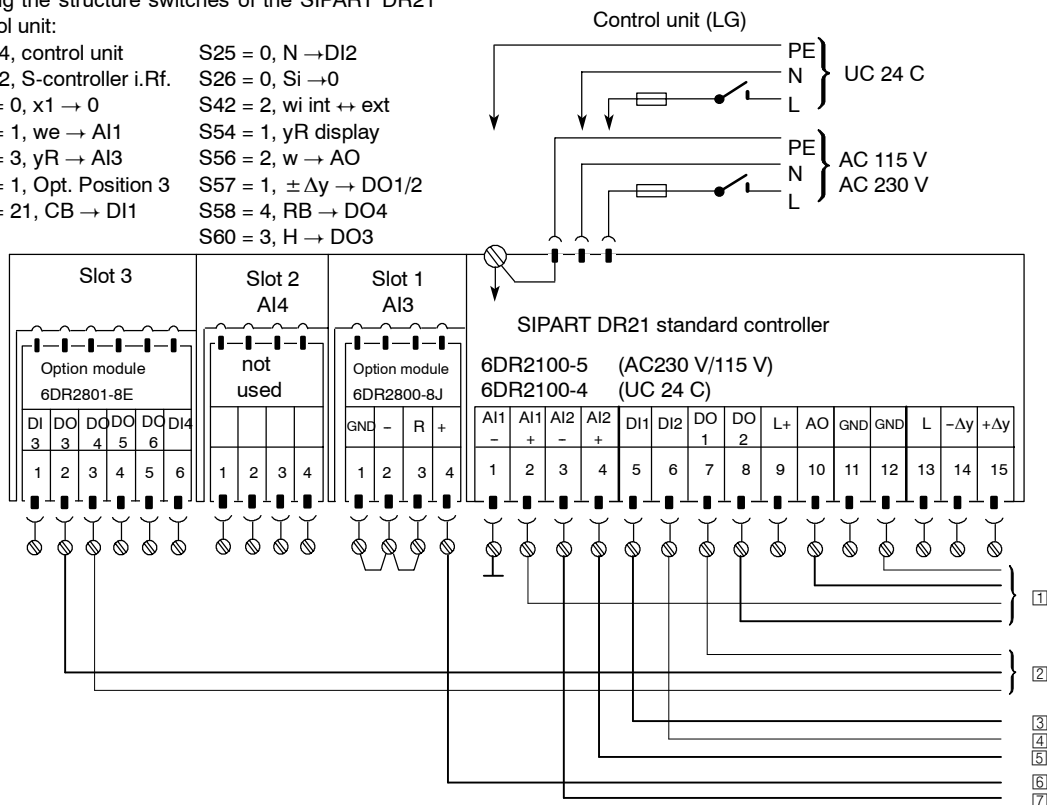

### Configuration example L4 continued

If the FR is switched to manual in this state, lighting of the LED (13) indicates tracking mode, flashing of LED (12) the ineffectiveness of the positioning keys (7) and (8). Tracking has priority over manual operation. Lighting of the LED (13) on the FR indicates tracking i.e. manual control from the control unit (LG). If the FR is now switched to manual, LED (13) flashes and the Manual LED lights steadily because manual operation has priority over tracking on the FR. The manipulated variable of the FR is controlled incrementally by the LG. Therefore the actuating time  $t_y$  (onPA) must be set to a finite value ( $t_y > 20$  s) otherwise the final value will be reached immediately when the positioning keys (7) or (8) are pressed briefly. See also chapter 3.4.6, page 80 and figure 3-17, page 86.

#### Slave controller SIPART DR22

Setting the structure switches of the SIPART DR22 slave controller:

- |                          |                        |
|--------------------------|------------------------|
| S1 = 3, slave controller | S61 = 1, H > N         |
| S16 = 0, FE2 → 0         | S62 = 1, yN → yNΔ      |
| S24 = 4, CB → DI4        | S74 = 18, w → AO2      |
| S25 = 0, He → 0          | S78 = 4, H → DO4       |
| S35 = 1, +Δy → DI1       | S85 = 8, Int → DO8     |
| S36 = 2, -Δy → DI2       | S89 = 1, N → $\bar{N}$ |
| S49 = 2, wi int ↔ ext    |                        |

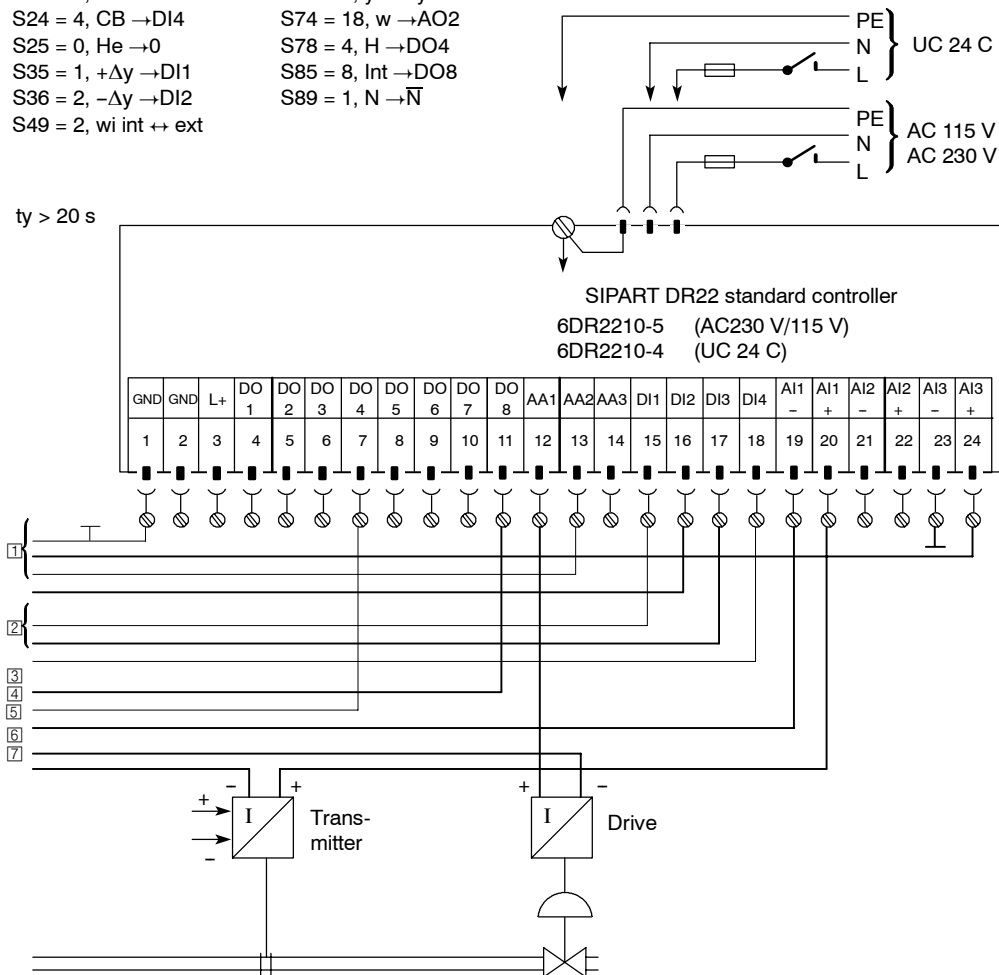

---

## 7.4 Configuring tool, forms

We recommend the following procedure for solving your controller problems:

- Determining the assembly of the controller
- If necessary: Determining the position of bridges and switches on the backplane module and signal transformers
- Drawing the wiring diagram
- Enter settings further down in the onPA, ofPA and Stru list (structuring, parameterizing)
- The SIMATIC PDM program is available for PC-supported configurations.

---

### For notes

---



## Circuit design

## K/S-controller 6DR2100-4/-5

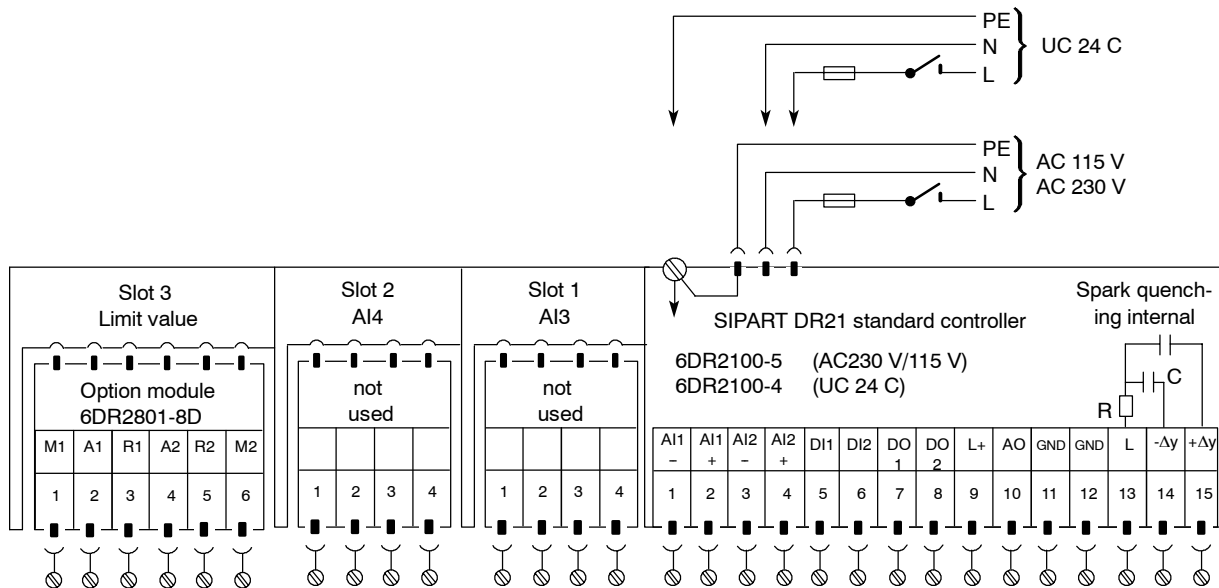

**Settings SIPART DR21, controller number / measuring point .....**

**Parameter onPA**

Parameter meaning	9 (y)	Digital indication on display				Factory setting	Dimension
		3 (w/x) for preset					
Filter time constant xd (adaptive)	tF					1.000	s
Derivative action gain	vv					5.000	1
Proportional gain factor	cP					0.100	1
Integral-action time	tn					9984	s
Derivative-action time	tv					oFF	s
Response threshold	AH					0.0	%
Operating point	YO					Auto	%
Output variable limiting start	YA					-5.0	%
Output variable limit end (YA ≤ YE)	YE					105.0	%
y actuating time open/period heating	tP					1.000	s
y actuating time open/period cooling	tM					1.000	s
min. actuating pulse pause	tA					200	ms
min. actuating pulse length	tE					200	ms
Filter time constant AI1	t1					1.000	s
Filter time constant AI2	t2					1.000	s
Filter time constant AI3	t3					1.000	s
Filter time constant AI4	t4					1.000	s
Multiplicative constant	c1					0.000	1
Multiplicative constant	c2					0.000	1
Additive constant	c3					0.000	100 %
Multiplicative constant	c4					1.000	1
Additive constant	c5					0.000	100 %
Multiplicative constant	c6					0.0	1
Multiplicative constant	c7					1.000	1
Display refresh rate	dr					1.000	s

**Settings SIPART DR21, controller number / measuring point .....****Parameter oFPA**

Parameter meaning	Digital indication on display				Factory setting	Dimension
	9 (y)	3 (w/x) for preset				
Decimal point w/x display		dP				---.-
Start of scale	dA				0.0	-
Full scale	dE				100.0	-
Alarm 1	A1				5,0	-
Alarm 2 (A2 ≤ A1)	A2				-5,0	-
Alarm 3	A3				5,0	-
Alarm 4 (A4 ≤ A3)	A4				-5,0	-
Hysteresis alarms	HA				1	%
Setpoint limit start	SA				-5,0	-
Setpoint limit end	SE				105,0	-
Safety setpoint	SH				0,0	-
Setpoint ramp time	tS				oFF	min
Ratio factor start	vA				0,000	1
Ratio factor end	vE				1,000	1
Safety output variable	YS				0,0	%
Split range left y1 (y1 ≤ y2)	Y1				50,0	%
Split range right y2	Y2				50,0	%
Vertex value at -10 %	L-1				-10	%
Vertex value at 0 %	L0				0	%
Vertex value at 10 %	L1				10	%
Vertex value at 20 %	L2				20	%
Vertex value at 30 %	L3				30	%
Vertex value at 40 %	L4				40	%
Vertex value at 50 %	L5				50	%
Vertex value at 60 %	L6				60	%
Vertex value at 70 %	L7				70	%
Vertex value at 80 %	L8				80	%
Vertex value at 90 %	L9				90	%
Vertex value at 100 %	L10				100	%
Vertex value at 110 %	L11				110	%
Decimal point	Pd				---.-	-
Start of scale	Ad				0,0	-
Full scale (only at S1 = 3)	Ed				100,0	-

**Settings SIPART DR21, controller number / measuring point .....**

**Parameter CAE3**

Parameter meaning	Digital indication on displays			
	16 (x)	19 (w)		
Sensor type	SEnS			
Temperature unit	unit			
Thermocouple type	tc			
Temperature reference point	tb			
Line resistance	Mr			
Decimal point measuring range	MP			
Range start	MA			
Range full scale	ME			

**Settings SIPART DR21, controller number / measuring point .....**

**Structure switches Stru**

Switch number	Preset				Factory setting	Switch number	Preset				Factory set.
1					0	52					0
2					0	53					0
3					0	54					0
4					0	55					0
5					0	56					0
6					0	57					0
7					0	58					0
8					0	59					0
9					0	60					0
10					0	61					0
11					0	62					1
12					0	63					2
13					0	64					0
14					0	65					0
15					1	66					0
16					2	67					0
17					3	68					0
18					4	69					0
19					0	70					0
20					0	71					0
21					0	72					0
22					0	73					0
23					8	74					0
24					0	75					0
25					1	76					0
26					2	77					0
27					0	78					0
28					0	79					0
29					0	80					0
30					0	81					0
31					0	82					0
32					0	83					0
33					0	84					0/1 <sup>1)</sup>
34					0	85					0/1 <sup>1)</sup>
35					0	86					0
36					0	87					0
37					0	88					0
38					0	89					0
39					0	90					0
40					0	91					0
41					0	92					0 <sup>2)</sup>
42					0						
43					0						
44					0						
45					0						
46					0						
47					0						
48					0						
49					0						
50					0						
51					0						

1) as of software version –A5

2) as of software version –B5



## 8 Maintenance

### 8.1 General information and handling

The controller is maintenance-free. White spirit or industrial alcohol is recommended for cleaning the front foil and the plastic housing if necessary.

be changed freely without readjustment with power supplied. The other modules may also be replaced without readjustment (procedure as described in chapter 8.2).



---

**CAUTION**

All modules contain components which are vulnerable to static. Observe the safety precautions!

---

S-actuators on S-controllers remain in their last position.



---

**WARNING**

The backplane module may only be changed after the power supply has been safely disconnected.

---



---

**WARNING**

Modules may only be repaired in an authorized workshop. This applies particularly to the backplane module because of the safety functions (safe disconnection and safety extra low voltages).

---

## 8.2 Exchanging components

### ● Replacing the front module

- Pull out the mains plug
- Remove the backplane module and any options modules which may be plugged in.
- Carefully lever out the label cover with a screwdriver at the cutout at the top and snap the cover out of the bottom hinge points by bending slightly.
- Loosen the fastening screw (captive) (see (2) fig. 8-1).
- Tilt the top of the front module at the head of the screw and pull it out angled slightly forwards.
- Install in reverse order. Make sure the sealing ring is positioned perfectly!

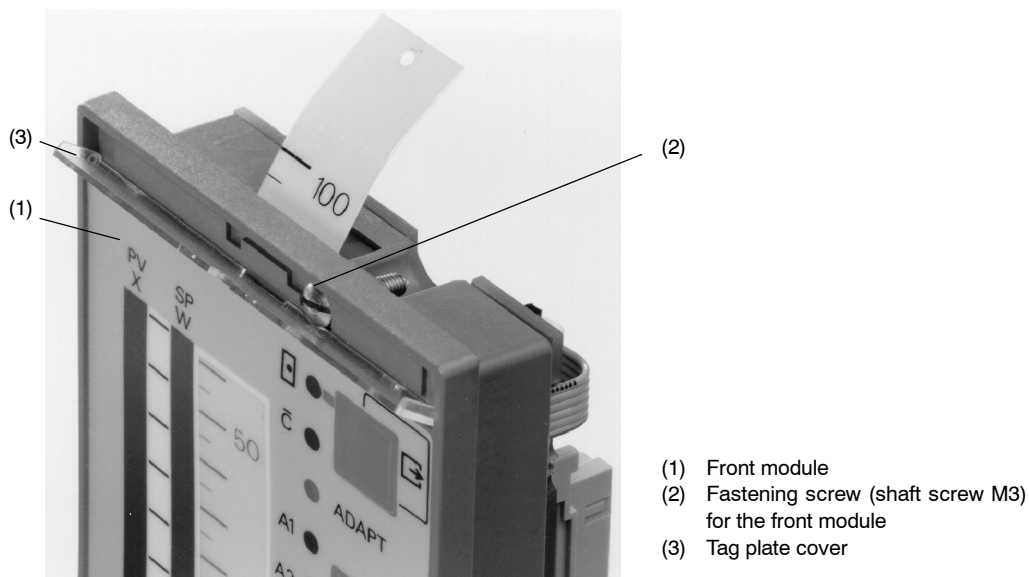

Figure 8-1 Front module with removed tag plate cover



- **Replacing the options modules**

- Pull off the plug terminals.
- Release the lock and remove the options module (see (6) figure 8-2).
- Push in the new module to the stop and lock it (the modules are slot coded). Please make sure the right modules are plugged into the slots provided for the different options (see chapter 2.4, page 24).
- Plug in the terminal (pay attention to slot labeling!),

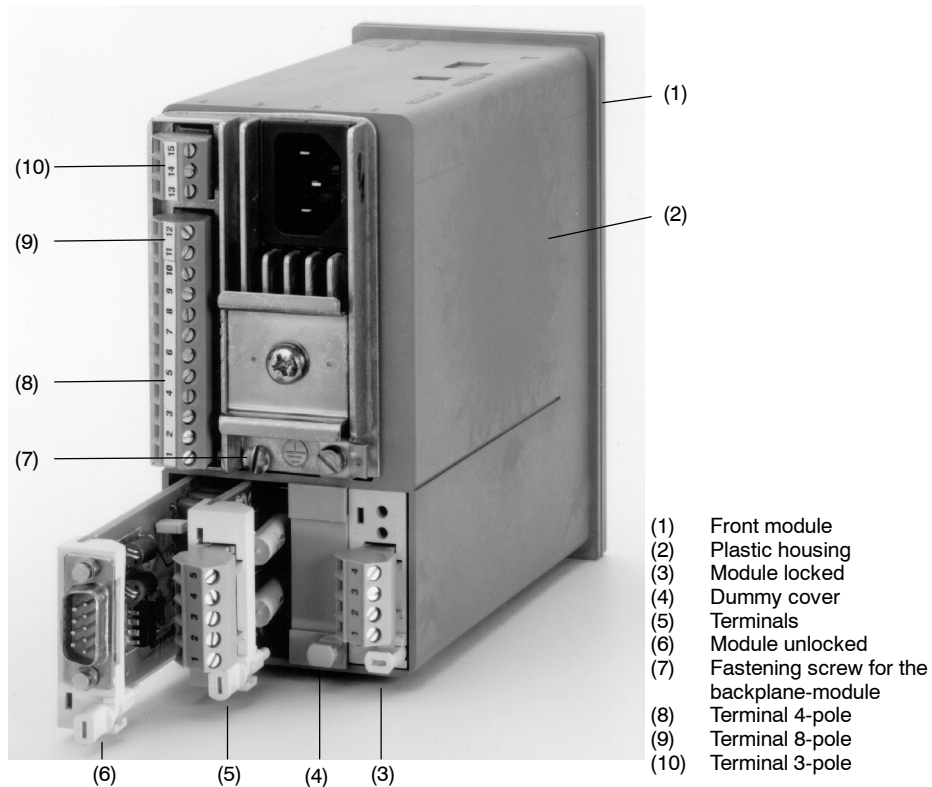

Figure 8-2 Controller rear view

- **Replacement of the backplane module (power supply unit + basic circuit board)**

- Pull out the mains plug!
- Pull off the plug terminals.
- Disconnect the PE conductor
- Loosen the fastening screw of the backplane module (see (2) fig. 8-2) and pull out the module.
- Install in reverse order.

- **Disconnect the power supply unit from the basic circuit board  
(Components of the backplane module)**

- Pull out the backplane module (see replacement of the backplane module)
- Pull out the ribbon cable plug (see (5) figure 8-3)
- Loosen the fastening screw of the basic circuit board (see (7) figure 8-3).
- Separate the basic circuit board and the power supply unit.
- Re-assemble in reverse order.  
(Pay attention to correct plugging of jumpers (see (3) figure 8-3))

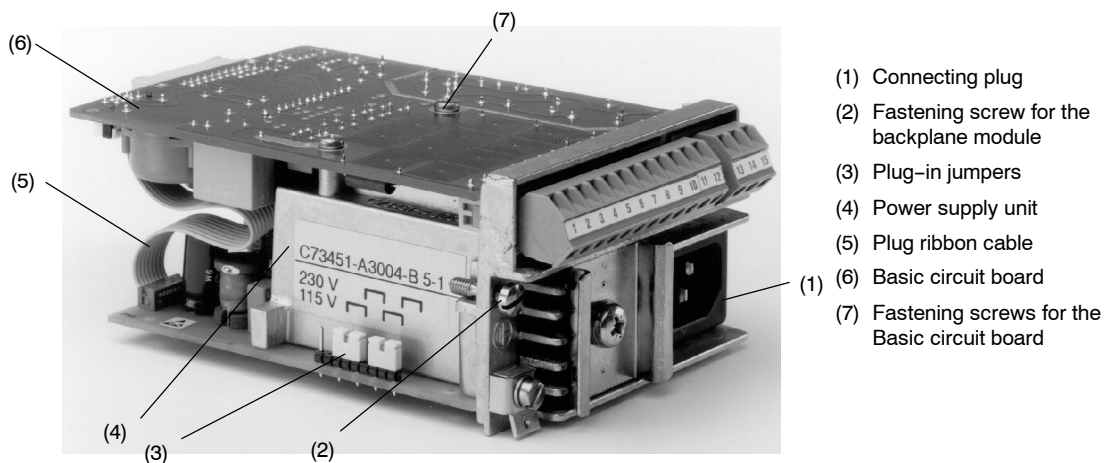

Figure 8-3 Backplane module

### 8.3 LED-test and software version

If the Shift key (6) is pressed for about 10 s (“PS” flashes on the manipulated variable display after about 5 s), this leads to the LED-test. All LEDs light up, the displays show “8.8.8.8.” or “88.” and a light marker covering 2 LEDs runs from 0 to 100% on both bargraphs (on reaching 100% it starts again at 0%).

If the Internal-/External key (16) is additionally pressed permanently during the lamp test, “dr21” appears on the digital x/w-display and the controller software version on the digital y-display.

During the LED-test and display of the software version the controller continues to operate on-line in its last operating mode.

## 8.4 Spare parts list

Item	Figure	Description	Comments	Order number
1		<b>Front module</b>		
1.1	(1) Figure 8-1	Front module complete		C73451-A3004-B112
1.2	(2) Figure 8-1	Shaft screw (M3)		D7964-L9010-S3
1.3	(3) Figure 8-1	Tag plate cover		C73451-A3001-C5
1.4	-	10 Tag plate labels		C73451-A3001-C16
2		<b>Housing</b>		
2.1	(2) Figure 8-2	Plastic housing		C73451-A3004-C3
2.2	(4) Figure 8-2	Dummy covers for unoccupied slots		C73451-A3000-C11
2.3	-	Clamps		C73451-A3000-B20
2.4	-	10 self-adhesive sealing rings (Front frame/panel)		C73451-A3000-C41
3		<b>Backplane module</b>		
3.1	(4) Figure 8-3	Power supply unit - 24 V UC	without mains plug	C73451-A3004-B8
3.2	"	- 115/230 V AC		C73451-A3004-B5
3.3	(6) Figure 8-3	Basic circuit board: S-/K-controller		C73451-A3004-L105
3.4	(8) Figure 8-2	Terminal: - 4-pole		W73078-B1003-A904
3.5	(9) Figure 8-2	- 8-pole		W73078-B1017-A908
3.6	(10) Figure 8-2	- 3-pole		W73078-B1018-A903
3.7	-	Mains plug: - 3-pin plug for 115/230 V AC IEC-230V, DIN 49457A		C73334-Z343-C3
3.8	-	- Special 2-pin plug for 24 V UC		C73334-Z343-C6
4	-	<b>Options</b>	see chapter 8.5, Ordering data	
4.1	-	Terminals: - 4-pin for 6DR2800-8J/8R		W73078-B1001-A904
4.2	-	- 4-pin for 6DR2800-8V		W73078-B1003-A904
4.3	-	- 5-pin for 6DR2801-8C		W73078-B1001-A705
4.4	-	- 6-pin for 6DR2801-8D/8E		W73078-B1001-A906

### • Ordering information

The order must contain:

- Quantity
- Order number
- Description

We recommend you to specify the controller order number to be on the safe side.

### • Ordering example

2 units W73078-B1003-A904  
Terminal 4-pin backplane module DR21

## 8.5 Ordering data

### SIPART DR21 process controller 72 x 144

S-/K-controller for

- Power supply UC 24 V ..... 6DR2100-4
- Power supply AC 230 V, can be switched to AC 115 V ..... 6DR2100-5

#### Options/accessories

Signal converter/analog signals

- for current input 0/4 to 20 mA or 0/0.2 to 1 V or 0/2 to 10 V (U/I-module) ..... 6DR2800-8J
- for resistance potentiometer (R-module) ..... 6DR2800-8R
- for TC/RTD/R/MV-signals, programmable (UNI-module) ..... 6DR2800-8V
- Reference point terminal for TC, internal ..... 6DR2805-8A
- Measuring range plug for I = 20 mA and U = 10 V ..... 6DR2805-8J

Signal converter/switching signals

- with 5 digital inputs (5DI-module) ..... 6DR2801-8C
- with 2 relay outputs (35 V) (2 DO-relay-module) ..... 6DR2801-8D
- with 4 digital outputs and 2 digital inputs (2DI 4DO-module) ..... 6DR2801-8E

Interface for serial communication RS 232/RS 485 ..... 6DR2803-8C

Interface for PROFIBUS DP RS 232/RS 485 ..... 6DR2803-8P

Coupling relay module for mounting on a DIN rail on the back of the controller

- with 4 relays (AC 250 V) ..... 6DR2804-8A
- with 2 relays (AC 250 V) ..... 6DR2804-8B

Assembly- and installation guide

- German/English ..... C73000-M7474-C35
- French/Spanish/Italian ..... C73000-M7450-C35

Quick Reference

- German/English ..... C73000-B7474-C141
- French/Spanish/Italian ..... C73000-B7450-C141

Manual

- German ..... C73000-B7400-C143
- English ..... C73000-B7476-C143

SIPART DR21 Serial SIPART DR210x bus interface / Operating Manual

can be downloaded from the INTERNET. Internet address: [www.fielddevices.com](http://www.fielddevices.com) (version 05/2000)

## 9 General explanation of abbreviations for SIPART DR

$\bar{A}$ .....	control signal no automatic mode
A* .....	Parameter Alarms (limit values)
Ad .....	
AdAP .....	Parameterization mode Adaptation
AdAPT .....	LED, adaptation mode
AH* .....	Response threshold (dead zone)
AI* .....	Analog inputs
AI*A .....	Outputs of the analog inputs
AO .....	Analog output
APSt .....	Structuring mode All Preset (whole controller to factory setting)
AUto .....	automatic
Ar* .....	Function block, Arithmetic
bLb .....	Control signal, Blocking, Operating
bLPS .....	Control signal, Blocking, Parameterization/Structuring
bLPS <sub>DI</sub> .....	Control signal, Blocking, Parameterization/Structuring via digital input
bLPS <sub>ES</sub> .....	Control signal, Blocking, Parameterization/Structuring via SES
bLS .....	Control signal, Blocking, Structuring
bLS <sub>DI</sub> .....	Control signal, Blocking, Structuring via digital input
bLS <sub>ES</sub> .....	Control signal, Blocking, Structuring via SES
c* .....	Parameter, Constants
$\bar{C}$ .....	LED, no computer standby
CA .....	Calibration, start of range
CAE3 .....	Parameterization mode, UNI-module
CB .....	Control signal, Computer operation
CB <sub>DI</sub> .....	Control signal, Computer operation via digital inputs
CB <sub>ES</sub> .....	Control signal, Computer operation via SES
cP .....	(K <sub>p</sub> ) Proportional action factor
CPU .....	central processing unit
Cr .....	Calibration, adjustment of line resistances (R <sub>L</sub> )
dA .....	Parameter, display range, start
DDC .....	direct digital control
dE .....	Parameter, display range, end
DI** .....	Digital inputs
DO** .....	Digital outputs
dP .....	Parameter, display decimal point
dPv .....	Parameter direction of step command
dr .....	Parameter, display refresh rate
dY .....	Parameter amplitude of the step command
Ed .....	
End .....	Error message end

---

Err	.....	Error
FAST	.....	Error message for adaptation, system too fast
HA	.....	Parameter, hysteresis alarms
H	.....	Control signal manual mode
Hi	.....	Control signal manual internal
He <sub>DI</sub>	.....	Control signal manual external via digital input
He <sub>ES</sub>	.....	Control signal manual external via SES
HE	.....	Error message manual external
HOLD	.....	Programm controller, comparison with end of interval with hold function
Int	.....	Control signal internal
Iy	.....	Analog output, current manipulated variable
Kp	.....	Proportional gain factor
LED	.....	light emitting diode
L1 to L11	.....	Parameter vertex points linearizer
MA*	.....	Start of measuring range
ME*	.....	Range full scale
MEM	.....	Memory
ModE	.....	Operating mode
MP*	.....	Parameter measuring decimal point
Mr*	.....	Parameter measuring of (R <sub>L</sub> ) line resistances
MUF	.....	Signal transmitter fault message
n.ddc	.....	Error message tracking or DDC
n.End	.....	Error message full scale value not reached
no	.....	no
no C	.....	Parameter setting (PC) nor calibrated
no.dY	.....	Error message, y-Step not correct
not	.....	none
nPoS	.....	not positioned
N	.....	Control signal tracking
N <sub>DI</sub>	.....	Control signal tracking via digital input
N <sub>ES</sub>	.....	Control signal tracking via SES
Nw	.....	Control signal tracking effective
oFL	.....	overflow, positive overflow
-oFL	.....	-overflow, negative overflow
onPA	.....	Parameterization mode, on-line-parameterization
oFPA	.....	Structuring mode, offline-parameterization
OP**	.....	Error message option (slot)
OUT	.....	Output, output variable y
ovEr Shot	.....	Error message overshoot

---









P	Control signal-P-operation
P <sub>DI</sub>	Control signal P-operation via digital input
P <sub>ES</sub>	Control signal P-operation via SES
PASS	Error message step response in wrong direction
PAU	Control signal parameter switching
PAU <sub>DI</sub>	Control signal parameter switching via digital input
PAU <sub>ES</sub>	Control signal parameter switching via SES
PC	Parameter Preset Calibration
P.oFL	Error message x above the span
PV	Process variable
$\overline{RB}$	Control signal, no computer standby
$\overline{RC}$	Control signal, no computer operation
S	Structure switch
SA	Parameter setpoint limiting start
Sb	Parameter limiting setpoint
SE	Parameter setpoint limiting end
SES	Serial interface
SG	Parameter controlling variable
SH	Parameter safety setpoint
Si	Control signal safety operation, error message safety operation
Si <sub>DI</sub>	Control signal safety operation via digital input
Si <sub>ES</sub>	Control signal safety operation via SES
SMAL	Error message small
SP	Setpoint
SPC	Setpoint control, setpoint via external system
StAt	Error message, stationary, static
StrS	Structuring mode, structure switch
StrU	Parameterization preselection level select structuring
t*	Filter time AI*
tA	Parameter minimum turn-off duration
tb	Parameter reference temperature
tE	Parameter minimum turn-on duration
tEst	Self-test
tF*	Parameter filter time constant
tM	Parameter y-actuating time closed/cooling time
tn	Parameter integral action time
tp	Parameter y-actuating time open/heating
tS	Parameter setpoint ramp
tSH	Parameter setpoint ramp "HALT"
to	to
tU	Monitoring time
tv	Parameter derivative action time
tY	Parameter actuating time

---

v	Setpoint ratio factor
$v_{act}$	Actual ratio factor
$v_A$	Parameter ratio factor range start
$v_E$	Parameter ratio factor range end
$v_v$	Derivative action gain
$v_{vc}$	Derivative action gain uncontrolled
w	Setpoint w
$w_E$	External setpoint
$w_{EA}$	External setpoint via analog input
$w_{ES}$	External setpoint via SES
$w_{E\Delta}$	External setpoint incremental
$w_i$	Internal setpoint
$w_v$	Standardized nominal ratio factor
x	Controlled variable x (actual value)
$x^*$	Auxiliary controlled variables, partial controlled variables
$x_d^*$	Control difference
$x_{ds}$	Control difference, position controller
$x_v$	Standardized actual ratio factor
$x_w$	Control error ( $-x_d$ )
y	Output variable
$y_1$	Partial output variables in split range
$y_2$	Partial output variables in split range
$Y_1$	Parameter output variable range 1 in split range
$Y_2$	Parameter output variable range 2 in split range
$Y_A$	Parameter output variable limit start
$Y_E$	Parameter output variable limit end
$y_E$	External output variable
YES	Reset parameter setting (PC) Calibration
$y_{ES}$	External output variable via SES
$y_{E\Delta}$	External output variable incremental
$y_H$	Manual output variable
$y_N$	External output variable (tracking output variable)
$y_S$	Safety output variable
$Y_S$	Parameter safety output variable
$Y_o$	Parameter operating point
YBL	Error message blocking mode
$y.oFL$	Error message y outside the setpoint limits
$\pm yBL$	Control signal direction-dependent y-Blocking
$\pm yBL_{DI}$	Control signal direction-dependent y-Blocking via digital inputs
$\pm yBL_{ES}$	Control signal direction-dependent y-Blocking via SES
$\pm \Delta w$	Control signal incremental w-Adjustment
$\pm \Delta w_{DI}$	Control signal incremental w-Adjustment by digital inputs



---

$\pm \Delta w_{ES}$ .....	Control signal incremental w-Adjustment by SES
$\pm \Delta y$ .....	Control signal incremental y-Adjustment
$\pm \Delta y_{DI}$ .....	Control signal incremental y-Adjustment by digital inputs
$\pm \Delta y_{ES}$ .....	Control signal incremental y-Adjustment by SES
$z$ .....	Disturbance variable
-1.1 to 11.1 .....	Parameter vertex points linearizer FE1
-1.3 to 11.3 .....	Parameter vertex points linearizer FE3
 .....	Controller
 .....	Internal
 .....	Manual (internal manipulated variable preset)
 .....	External (tracking)
 .....	Exit
 .....	Enter
 .....	Fault
 $AI^{**}$ .....	Error message Fault analog inputs
--- • - .....	Identification decimal point
 .....	adjustable
**..0 .....	old parameters
**..n .....	new parameters
* .....	stands for counter number or parameter name



## Index

### Numbers

- 6DR210x-4, Connection, 130
- 6DR210x-5, Connection, 130
- 6DR2800-8J
  - Connection, 133
  - Connection example, 137
  - Function principle of the option module, 28
  - Technical Data, 40
- 6DR2800-8R
  - Connection, 134
  - Function principle of the option modules, 28
  - Technical Data, 40
- 6DR2800-8V
  - Connection, 135
  - Function principle of the option modules, 29
  - Technical Data, 41
- 6DR2801-8C, 142
  - Function principle of the option modules, 31
  - Technical Data, 43
- 6DR2801-8D, 143
  - Function principle of the option modules, 30
  - Technical Data, 42
- 6DR2801-8E, 142
  - Function principle of the option modules, 30
  - Technical Data, 43
- 6DR2803-8C, 144
  - Function principle of the option modules, 32
  - Technical Data, 44
- 6DR2803-8P, 146
  - Connection, 147
  - Function principle of the option modules, 31
  - Technical Data, 43
- 6DR2804-8A, 143
- 6DR2804-8A/B, Technical Data, 45
- 6DR2804-8B, 143
- 6DR2805-8A, Function principle of the option modules, 29
- 6DR2805-8J, 135
  - Function principle of the option modules, 30
  - Technical Data, 42

### A

- A/D converter, Technical Data, 38
- A1 to A4, Digital outputs, Features, 22
- Actual value, 150
- Actual value display, Functional explanation, 58
- Actuating time  $t_p$  and  $t_M$ , 94
- AdAP, 186
  - Configuration mode, 156
  - Parameter list, 161
- Adaptation, 113
  - Aborted, 157
  - Condition, 157
  - Error messages, 162
- Adaptive filter, 115, 185
- Alarm LED, 151
- Amplitude of the step command, 186
- Analog input, Universal module, 135
- Analog inputs
  - Features, 19
  - Functional principle of the standard controller, 26
  - Technical Data, 36
- Analog output signal processing (S56), 110
- Analog outputs, Technical Data, 37
- AO, Connection, 131
- Application examples, 193
- APSt, 178
  - Configuring, 27
- Automatic mode, Controller output structure, 107

### B

- Backplane module
  - Removal, 121
  - Replacing, 225
- Backplane module with power supply unit, Design, 24
- bLb
  - Digital outputs, Features, 21
  - Functional explanation, 54
  - Operating locks, 149

- Block diagram, 129
- bLPS
  - Digital outputs, Features, 21
  - Functional explanation, 54
  - Operating locks, 149
- bLS
  - Digital outputs, Features, 21
  - Functional explanation, 54
- bLS, Operating locks, 149
  
- C**
- CAE3, Set UNI-module, 173
- Cascade controls, 63
- CB
  - Digital outputs, Features, 21
  - Functional explanation, 54
- Changing the scales, 123
- Changing the tag plate, 123
- Commissioning, 181
- Configuration examples, 199
- Configuration mode, 149, 154
  - AdAP (adaptation), 156
  - oFPA (offline parameters), 163
  - onPA (online parameters), 155
  - StrS (structure switch), 165
- Configuring, Functional principle of the standard controller, 27
- Configuring the controller, Application examples, 193
- Configuring tool, 216
  - for structuring, 221
  - to oFPA, 219
  - to onPA, 218
- Connecting elements, Arrangement, 126
- Connection
  - 6DR210x-4, 130
  - 6DR210x-5, 130
  - 6DR2800-8J, 133
  - 6DR2800-8R, 134
  - 6DR2800-8V, 135
  - AO, 131
  - Options modules, 133
  - DI1 to DI2, 131
  - DO1 to DO2, 132
  - Electrical, 126
  - Examples, 137
  - Ground, 128
  - Interface module, 144
  - Measuring lines, 127, 130
  - PE conductor, 126
  - Power Supply, 126, 130
  - PROFIBUS-DP, 147
  - RS 232, 144
  - Signal lines, 127, 130
  - Standard controller, 130
- Connection technique, Design, 25
- Constants c1 to c7, Functional explanation, 57
- Control algorithm, 91
- Control parameters
  - automatic setting, 186
  - Setting by the adaptation method, 189
- Control signals
  - for setpoint switching, 63
  - Functional explanation, 54, 57
- Display range, Functional explanation, 58
- Control system coupling, 89, 90
  - via serial interface, 109
- Control unit, 80, 83
  - DDC fixed setpoint controller, 69
- Controlled ratio controller, 75
- Controlled system with compensation, Transient function, 191
- Controlled variable processing, 64
- Controller, installing, 124
- Controller design, Adaptation, 114
- Controller direction of control action, Adaptation to controlled system, 181
- Controller direction of effect, 91
- Controller output structure
  - S2=0, 94
  - S2=1, 95
  - S2=2, 99
  - S2=3, 102
- Controller output structures, 94
- Controller types, 55
- Controls
  - SPC, 63
  - Cascade, 63
  - Synchronized, 63
- Coupling relay, Technical Data, 45

- CPU
  - Functional principle of the standard controller, 26
  - self-diagnostics, 179
- D**
- DDC fixed setpoint controller, 68
  - Control unit, 69
- Design, 24
- DI1 to DI2, Connection, 131
- Digital inputs
  - Assignment and direction of effect, 50
  - Features, 21, 22
  - Functional principle of the standard controller, 26
  - Linking with the control signals, 50
  - Technical Data, 37
- Digital output signal processing (S57 to S75), 111
- Digital outputs
  - Features
    - A1 to A4, 22
    - bLb, 21
    - bLPS, 21
    - bLS, 21
    - CB, 21
    - H, 22
    - He, 21
    - MUF, 22
    - N, 21
    - Nw, 22
    - P, 21
    - RB, 22
    - RC, 22
    - Si, 21
    - tS, 21
    - tSH, 21
    - w, 22
    - y, 22
    - yBL, 21
  - Functional principle of the standard controller, 26
  - Technical Data, 38
- Direction of control action, 181
  - of actuator, 181
  - of system, 181
- Direction of effect
  - actuator, 182
  - system, 182
- Direction-dependent blocking operation, 108
- Display, software version, 151
- Display levels, 73
- Display technique, Technical Data, 39
- DO1 to DO2, Connection, 132
- dy – amplitude of the step command, Presetting, 186
- E**
- Error messages, Adaptation, 162
- Explanation of abbreviations, 229
- external setpoint wE, 64
- F**
- Factory setting, 178
  - Behavior of the controller, 150
- Features, 19
- Filter, Setting, 185
- Fixed setpoint controller
  - DDC, 68
  - with 2 independent setpoints, 59
  - with one setpoint (control system coupling), 89
- Front module
  - Design, 24
  - Replacing, 224
- Function principle, 26
- Functional description
  - Controller types, 55
  - Structure switches, 47
- Functional explanation, of the digital message signals, 111
- Fundamental control technology terms, 9
  - Actuators, 9
  - Controller output signal, 12
  - Continuous controller, 13
  - Control loop, 9
  - control response, 10
  - Three-position step controller with internal feedback, 12
  - Final control elements, 9
  - P controller, 10
  - PD controller, 11
  - PI controller, 11
  - PID controller, 11

- Sensor, 9
  - Step function, 10
  - transmitter, 9
  - Two-position controller, 14
- H**
- H, Digital outputs, Features, 22
  - He
    - Digital outputs, Features, 21
    - Functional explanation, 54
- I**
- I/U module, Function principle of the option modules, 28
  - Installation, 121
    - Selecting the Installation Site, 121
  - Internet address:, 31
- K**
- K controller
    - Direction of effect, 181
    - Setting the floating time, 183
  - Kp, 187
- L**
- Lamp test, 151
  - Limit value alarms, 117
  - Line capacitance, Technical Data, 44
  - Linearizer, 118
- M**
- Maintenance, 223
  - Manipulated variable, 150
  - Manipulated variable adjustment, Technical Data, 38
  - Manipulated variable limit, 93
  - Manual control station, 85
  - Manual mode, 107
    - absolute ~, 154
  - Measuring inputs, Modules, 133
  - Measuring range
    - I, 175
    - mV, 175
  - Pt100, 176
  - Resistance potentiometer, 177
  - Thermocouples, 175
  - U, 175
  - Measuring range plug
    - Function principle of the option modules, 30
    - Pin assignment, 135
    - Technical Data, 42
  - Measuring transmitter feed, Technical Data, 38
  - Mechanical Installation, 121
  - Modules
    - for analog measuring inputs, 133
    - for expanding the digital inputs, 142
    - for expanding the digital outputs, 142
  - Monitoring time tU, Presetting, 186
  - MUF, Digital outputs, Features, 22
  - mV transmitter, Pin assignment, 135
- N**
- N**
- Digital outputs, Features, 21
  - Functional explanation, 54
  - Tracking N, Functional explanation, 56
  - Nw, Digital outputs, Features, 22
- O**
- Offline mode, 154
    - Parameter list, 164
  - oFPA
    - Configuration mode, 163
    - Configuring, 27
    - Configuring tool, 219
  - Online mode, 154
    - Parameter list, 155
  - onPA
    - Configuration mode, 155
    - Configuring, 27
    - Configuring tool, 218
  - Operating locks, 149
    - bLb, 149
    - bLPS, 149
    - bLS, 149
  - Operating point
    - automatic, 93
    - fixed, 93

- y0 in P-controller, 93
- Operation, 149
- Operation mode
  - Configuration mode, 149
  - Process operation mode, 149
  - Selection level, 149
- Operation with 2 or 3 setpoints, 64
- Option module, Function principle, 28
- Options modules
  - Connection, 133
  - Installation, 125
  - Replacing, 225
- Ordering data, 228
- Output signal processing
  - analog, 110
  - digital, 111
- Output structure, Features, 19
- Outputs for the manipulated variable Y, Functional principle of the standard controller, 26
- P**
- P
  - Digital outputs, Features, 21
  - Functional explanation, 54
- P-controller, 91
  - Setting, 189
- Parameter list
  - AdAP, 161
  - oFPA (offline parameters), 164
  - onPA (online parameters), 155
- parameters, Technical Data, 39
- PD-controller, Setting, 189
- PI-controller, 91
- PI-controller, Setting, 190
- PID controller, Setting, 190
- Pin assignment
  - Measuring range plug, 135
  - mV transmitter, 135
  - Pt100 sensor, 136
  - Resistance potentiometer, 137
  - Thermocouples, 136
- Power Supply, Standard controller, 36
- Power supply unit
  - Features, 20
  - Functional principle of the standard controller, 27
- Presetting
  - Amplitude of the step command dy, 186
  - Direction of step command Pv, 186
  - Monitoring time tU, 186
- Process display, 80
- Process operation mode, 149, **150**
- PROFIBUS DP, 120
  - Technical Data, 43
- PROFIBUS-DP, 146
  - Connection, 147
  - Structure switches, 173
- PT100, Measuring range, 176
- Pt100 sensor, Pin assignment, 136
- Pv – Direction of step command, Presetting, 186
- R**
- R, 137
- R module, Function principle of the option modules, 28
- Range of Application, 18
- Ratio controller
  - controlled, 75
  - Example, 78
- RB, Digital outputs, Features, 22
- RC, Digital outputs, Features, 22
- Rear of controller, 121
- reference point, Function principle of the option modules, 29
- Relay contacts, unlock, 122
- Replacing
  - Backplane module, 225
  - Front module, 224
  - Options modules, 225
- Resistance potentiometer
  - Measuring range, 177
  - Pin assignment, 137
- Resistor input, 134
- Response threshold, Setting, 185
- Response threshold AH, 116
- Restart conditions, 120

RS 485, 145

RTD, 136

## S

S controller

Adaptation to the actuating drive, 183

Direction of effect, 182

S-output, Technical Data, 37

S2=0, Controller output structure, 94

S2=1, Controller output structure, 95

S2=2, Controller output structure, 99

S2=3, Controller output structure, 102

SA, Functional explanation, 56

Safety notes, 17

Safety operation, 107

Scope of delivery, 17

SE, Functional explanation, 56

Selecting the control behavior, 186

Selection level, 149

Selection mode, 152

Serial interface, 120

Control system coupling, 109

Features, 22

PROFIBUS-DP, Function principle of the option modules, 31

RS 232/RS 485, Function principle of the option modules, 32

Technical Data, 44

Setpoint, 150

Setpoint change tSH, Functional explanation, 54

Setpoint display, Functional explanation, 58

Setpoint limits SA and SE, Functional explanation, 56

Setpoint potentiometer, 83

Setpoint ramp tS

Functional description, 55

Functional explanation, 54

Setpoints, 195

Setting

P-controller, 189

PD-controller, 189

PI-controller, 190

PID controller, 190

the control parameters automatically, 186

the control parameters manually, 189, 191

Si

Digital outputs, Features, 21

Functional explanation, 54

Slave controller, 62

without Int/Ext switching, 90

software version, Display, 151

Spare parts list, 227

SPC controls, 63

SPC-controller, 62

Standard controller

Connection, 130

Design, 24

Function principle, 26

Other functions, 115

Power Supply, 36

Start parameters, 161

Step command, Presetting, 186

StrS

Configuration mode, 165

Configuring, 27

Structure switches, 166

Stru, Configuring tool, 221

Structure switch list, 166

Structure switches

Analog input signal processing, 47

Configuring tool, 221

Digital input signal processing, 50

Functional description, 47

Switching

P-PI, 94

to automatic mode, 94

Switching over to manual operation, 47, 108

Synchronized controller, 62

Synchronized controls, 63

System identification, Adaptation, 113

## T

TC, 136

Technical Data, 34

Technical Description, 17

Thermocouples

Measuring range, 175

Pin assignment, 136

Tracking operation, 107



- Transient function, of a controlled system with compensation, 191
- Transmitter fault, Switching over to manual operation, 47, 108
- tS**
- Digital outputs, Features, 21
  - Functional description, 55
  - Functional explanation, 54
- tSH**
- Digital outputs, Features, 21
  - Functional explanation, 54
- tU (monitoring time), Presetting, 186
- U**
- UNI module:
- Function principle of the option modules, 29
  - Technical Data, 41
- Universal module for analog input, 135
- V**
- Voltage output, Features, 20
- W**
- w, Digital outputs, Features, 22
- wE, 64
- wi
- Functional description, 55
  - Manual setpoint setting, 55
- Work prior to installation, 121
- Working with different setpoints, 195
- wvi, Nominal ratio setting, 55
- X**
- x-tracking (S43), Functional explanation, 56
- Y**
- y, Digital outputs, Features, 22
- y display, 59, 98
- Source and direction of effect, 108
- yBL
- Digital outputs, Features, 21
  - Functional explanation, 54
- Z**
- zD, 91
- zy, 91

