

Ultrasonic Level Meter

User Manual

(Version 21)



CONTENTS

| | |
|---|-----------|
| 1.Product Introduction | 02 |
| 2.Debugging | 02 |
| 3.Main Technical Specifications | 03 |
| 4.Installation Guide | 03 |
| 4.1 Level Meter Installation Dimension | 03 |
| 4.2 Installation Guide..... | 04 |
| 4.2.1 Understanding of the terms | 04 |
| 4.2.2 Measuring range selection | 04 |
| 4.2.3 Liquid measurement..... | 07 |
| 4.3.1 Measure solid | 13 |
| 4.3.2 How to extend guide tube when measure solid | 15 |
| 4.3.3 Installation to avoid false echoes..... | 18 |
| 5. Wiring..... | 25 |
| 5.1 Output Active | 25 |
| 5.2 Output Passive | 26 |
| 6.Setting | 27 |
| 6.1 Interface in Operation Mode | 27 |
| 6.2 Interface Introduction..... | 28 |
| 6.3 Operation Menu..... | 29 |
| 6.3.1 Basic function menu..... | 29 |
| 6.3.2 Password 00050 enter category operation menu..... | 30 |
| 6.3.3 Password 00060 enter category operation menu..... | 32 |
| 6.3.4 Password 00070 enter category operation menu..... | 32 |

Tips: As the product is updated constantly, there is no guarantee the product specification and installation is fully consistent with the latest products. The part change contains but not limited to the following sections.

1. Blind zone, performance parameter, function, structure, shape, color and so on.
2. Software function, structure, display mode, operating habits and so on.

And please be noted:

1. For any operation of the hardware, it must be done after the power off. It is not within the warranty if short-circuit or the other faults due to the operation with electricity.
2. Please power off before opening the cover, and it is not allowed liquid flow into the meter.

For ultrasonic level meter, under normal circumstances, after installing it correctly based on manual, you only need to set the following parameters, the meter will working normally.

Distance Measurement: From Sensor emission area to liquid surface, 4-20mA output is corresponding to the distance high level and low level.

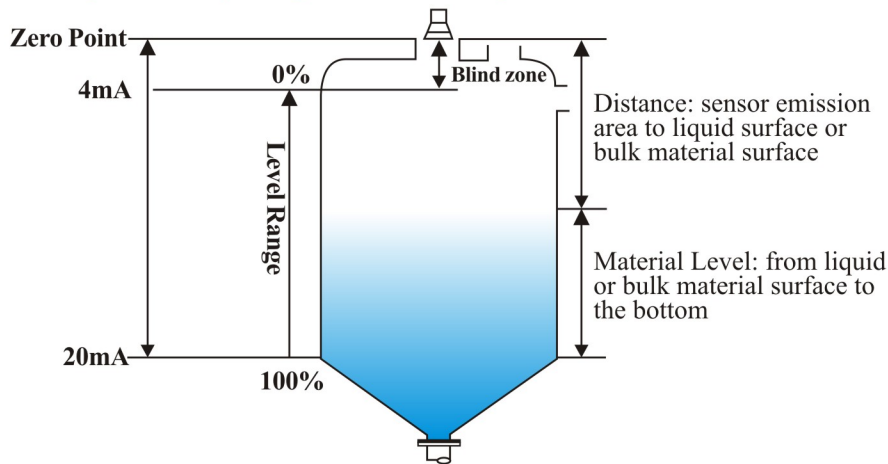

Diagram of Distance Measurement

Level Measurement: From water surface to bottom, 4-20mA output is corresponding to the water high level and low level.

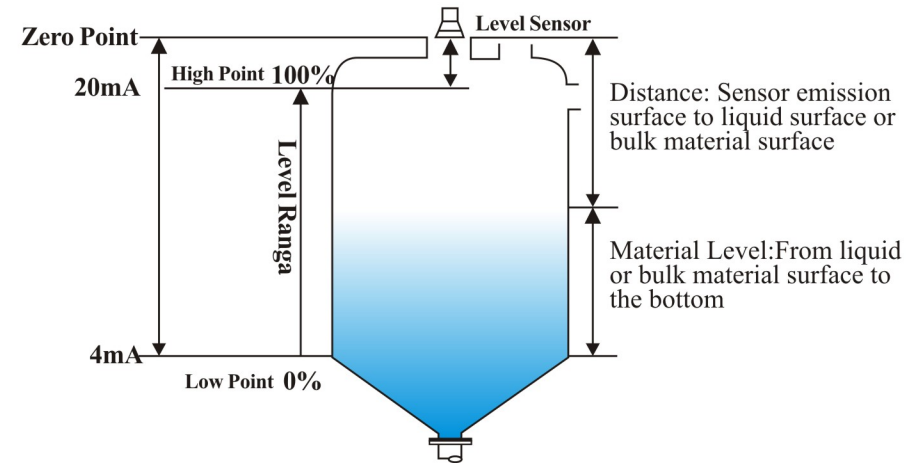

Diagram Description:

- ★ This is an important reminder, please read carefully and do exactly as required.
- ▲ This is a general hint, please read carefully in case any trouble in use.

1. Product Introduction

Ultrasonic level meter (for bulk material level or liquid level) is a level measuring device with the features of non-contact, high reliability, cost-effective, easy to be installed and maintained.

2. Debugging

Because the different installation situation for different application, we must know the basic conditions of the measurement before using it, such as: Measuring range, zero points, full level range and working condition etc. Therefore, the instrument must be configured well before installation.

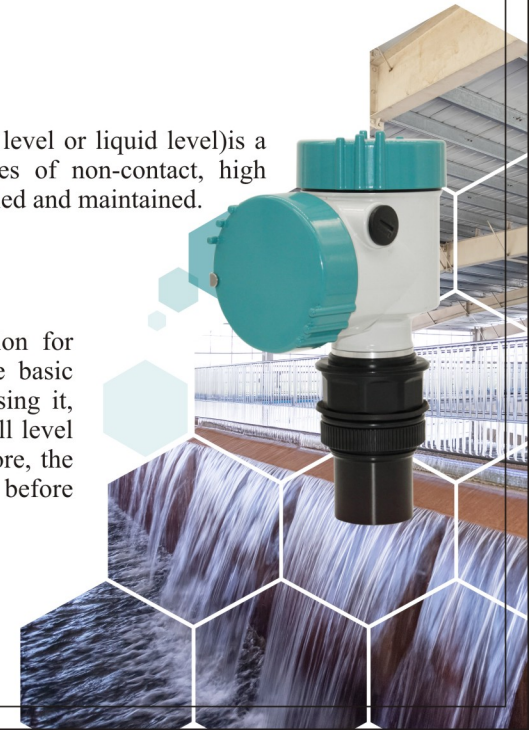

3. Main Technical Specifications

| Function | Compact Type |
|---------------------------|---|
| Level Range | 5, 10, 15, 20 m |
| Accuracy | 0.5%-1.0% |
| Resolution | 3mm or 0.1% |
| Display | LCD Display |
| Output | Two Wire 4 ~ 20mA / 250Ω Load, HART |
| Relay Output | No |
| Power Supply | Standard 24VDC |
| Environmental Temperature | Transmitter -20 ~ +60°C, Sensor -20 ~ +80°C |
| Communication | No |
| Protection Class | Transmitter IP65, Sensor IP68 |
| Cable | No |
| Probe Installation | Based on the level range |

4. Installation Guide

4.1 Level Meter Installation Dimension



Side View



Front View

4.2 Installation Guide

4.2.1 Understanding of the Terms

① Level Range

When we do the model selection, the meaning of the level range is very important, please check the following schematic.

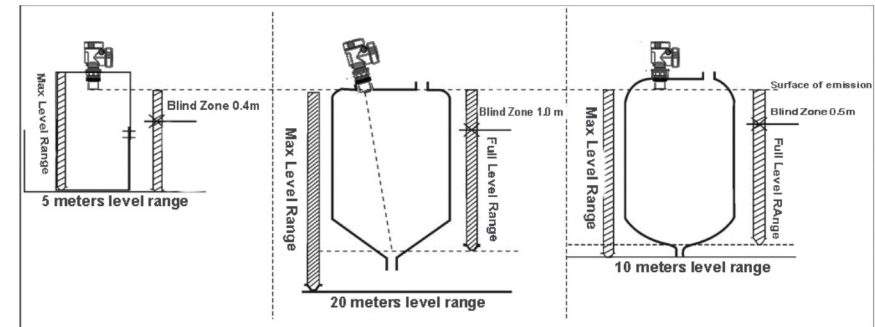

② Beam Angle and False Echo

Ultrasonic wave are focused through the probe, the pulse wave is just as the light from a flashlight, the further away from the probe, the greater the diffusion area.

Any object in the emission angle (such as pipe, bracket, weld seam, reinforcing rib, stirring propeller and wall-hanging object) will cause strong false echo especially the object near the probe.

For example: It is 9 times stronger for the false echo caused from the probe 6 meters away from the pipe than the probe 18 meters away from the same pipeline.

Try to make the axis of the sensor perpendicular to the surface of the media and avoid any other objects in the emission angle. such as: pipelines and brackets.

4.2.2 Measuring Range Selection

The measuring range depends on the range of the ultrasonic probe. The range of probes relate to the working environment, the medium, the temperature and so on.

According to the table below, you can choose what level range you need.

| Liquid Surface Status | Attenuation Multiples | Percentage of Attenuation | To Enlarge the Level Range |
|--|-----------------------|---------------------------|----------------------------|
| Stable | 0dB | 0% | No need |
| Small Wave | 5...10dB | 50 ~ 67% | 2 times of level range |
| Large wave(such as with mixing impeller) | 10...20dB | 90% | 3 times of level range |

| Solid Material Surface | Attenuation Multiples | Percentage of Attenuation | To Enlarge the Level Range |
|---|-----------------------|---------------------------|----------------------------|
| Hard, rough material (such as granulated rubber) | 40dB | 99% | 10 times of level range |
| Soft Material(Such as coal, cement powder, fly ash) | 40...60dB | 99 ~ 99.9% | Not Suitable |

| Dust | Attenuation Multiples | Percentage of Attenuation | To Enlarge the Level Range |
|----------|-----------------------|---------------------------|----------------------------|
| No | 0dB | 0% | No need |
| A Little | 5dB | 50% | 2 times of level range |
| Large | 5...20dB | 50 ~ 90% | 3 times of level range |

| Feeding Material | Attenuation Multiples | Percentage of Attenuation | To Enlarge the Level Range |
|------------------|-----------------------|---------------------------|----------------------------|
| No | 0dB | 0% | No need |
| A Little | 5...10dB | 50 ~ 67% | 2 times of level range |
| Large | 10...40dB | 67 ~ 99% | 3 times of level range |

| Mist/Vapor | Attenuation Multiples | Percentage of Attenuation | To Enlarge the Level Range |
|------------|-----------------------|---------------------------|----------------------------|
| No | 0dB | 0% | No need |
| A Little | 5...10dB | 50 ~ 67% | 2 times of level range |
| Large | 10...20dB | 67 ~ 90% | 3 times of level range |

| Steam | Attenuation Multiples | Percentage of Attenuation | To Enlarge the Level Range |
|----------|-----------------------|---------------------------|----------------------------|
| No | 0dB | 0% | No need |
| A Little | 5...10dB | 50 ~ 67% | 2 times of level range |
| Large | 10...20dB | 67 ~ 90% | 3 times of level range |

| The temperature difference between the probe and the medium | Attenuation Multiples | Percentage of Attenuation | To Enlarge the Level Range |
|---|-----------------------|---------------------------|----------------------------|
| ≤20°C | 0dB | 0% | No need |
| ≤40°C | 5...10dB | 50 ~ 67% | 2 times of level range |
| ≤80°C | 10...20dB | 67 ~ 90% | 3 times of level range |

Signal attenuation calculation: if there are many situations, it is necessary to accumulate these several cases to get the amount of signal attenuation.

- With a little feeding 5...10dB
- With a little steam 5...20dB
- Probe and medium surface temperature difference ≤40°C 5...10dB
- A small amount of feed 5...10dB
- A small amount of steam 5...20dB
- Probe and dielectric surface temperature difference ≤40°C 5...10dB

Total: Minimum 15dB, Max 40dB

In such case, if the actual maximum measurement range is 5 meters, then we need to choose 50 m level range ultrasonic level meter.

4.2.3 Liquid Measurement

4.2.3.1 Flat-topped Tanks/Cans

Flat-topped cans generally have a very short neck, the base surface of the neck is the bottom surface of the flange, on the premise of below:

Neck length $\leq 60\text{mm}$;

The pipe diameter $\geq 100\text{mm}$;

The inner wall of nozzle is flat without burr and convex object, then just need the emission surface of the probe (after installation) 3cm lower than the bottom surface of the flange.

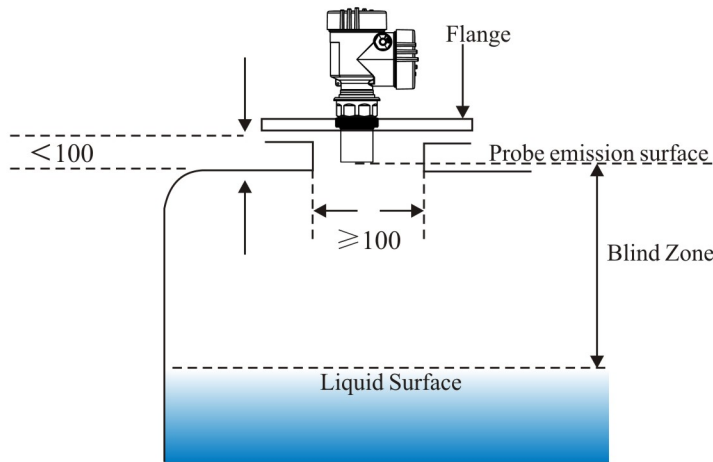

Flange Connection, installed in a very short neck

The ideal place is to install the instrument directly on the flat-topped container without using a neck, and the circular openings on the container can be fixed enough for the flange or universal flange. The probe was launched under the base level.

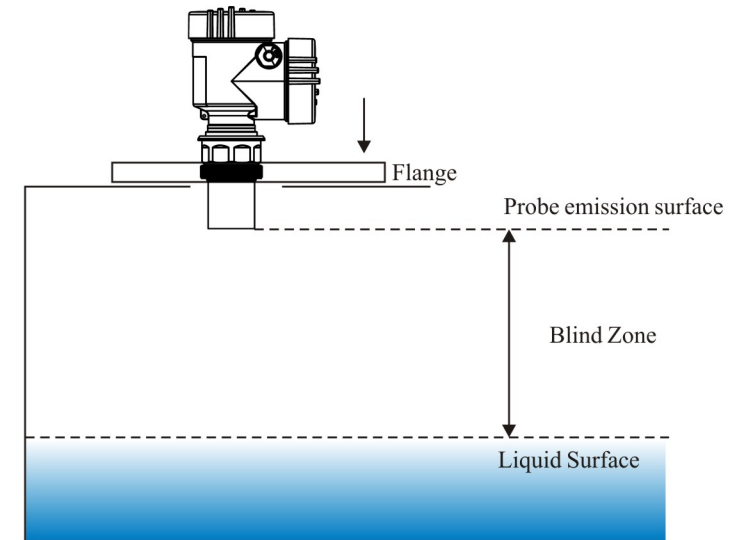

Flange type (locking flange), installed on the flat top tank

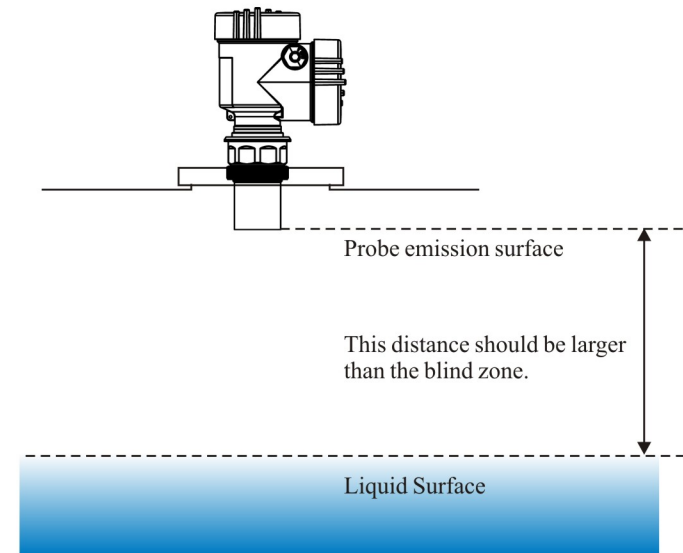

Flange type mounted on non-nozzle flat tank

Mounted on threaded neck same as probe, in such case the diameter of the neck is almost the same as the external thread of the probe, and the emission surface of the probe must be extended over 1cm.

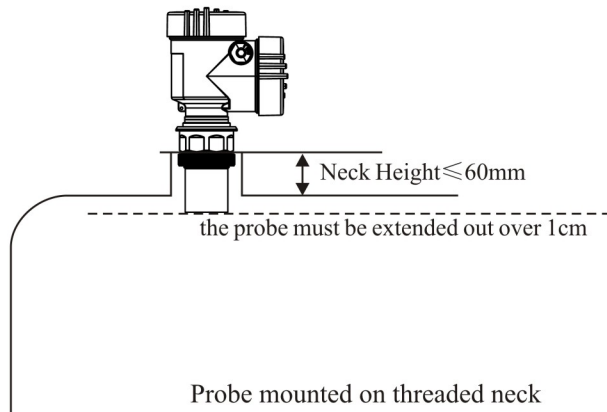

4.2.3.2 Arched Tank

For arched tank, ultrasonic level meter should be installed in the 1/2 or 2/3 (keep a certain distance from tank wall) of top radius of tank, instead of in the center of tank top. For ultrasonic pulse, arched tank roof is a convex glass, if probe is installed in the focal point, it will receive false echo, so it should be avoided to be installed in the center of the arched tank roof.

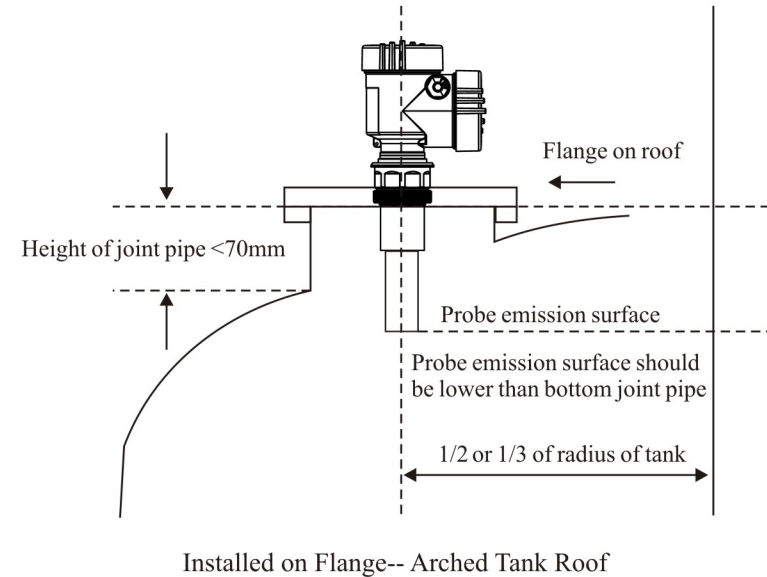
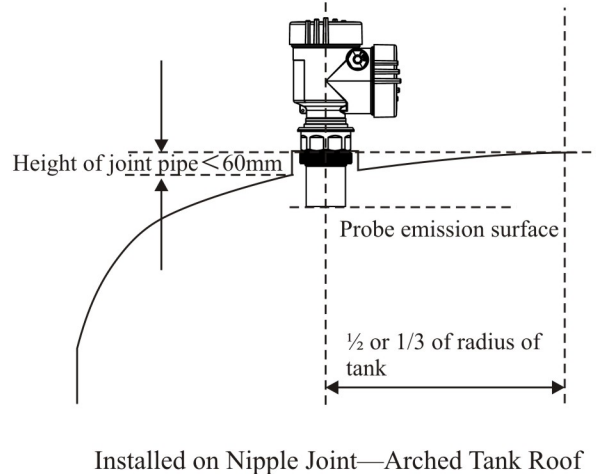

The length of joint pipe and flange is 150-180mm on many arched tank roof, but the length of probe plus thread is shorter than it (extended probe can be provided to make sure the probe emission surface lower than joint pipe bottom). In this case, we should pay attention to the ratio between length and min diameter size of joint pipe, the downward exit must cut a 45 °angle.

| No. | Length of joint pipe | Min diameter size of joint pipe | Note |
|-----|----------------------|---------------------------------|---|
| 1 | 150mm | 100mm | No burr and protruding object of joint pipe inner wall, keep vertical, all welding joint should be polished, the joint pipe and tank top connection point need make an angle of 45 ° polished from the inside to the outside of the joint pipe. |
| 2 | 200mm | 150mm | |
| 3 | 250mm | 180mm | |
| 4 | 300mm | 220mm | |
| 5 | 400mm | 280mm | |

4.2.3.3 Open Vessel

For open vessel, user can install use bracket, but please pay attention to the weight capacity of bracket and keep a certain distance from probe to the inner wall of vessel. If the open vessel or inner wall is smooth and no burr, no other objects adhesive to the inner wall, the distance from probe to inner wall is shown in the following table.

| Max measuring range | Min distance from tank wall | Max measuring range | Min distance from tank wall | Max measuring range | Min distance from tank wall |
|---------------------|-----------------------------|---------------------|-----------------------------|---------------------|-----------------------------|
| 5m | 0.5m | 10m | 1.0m | 15m | 1.5m |
| 20m | 2.5m | 30m | 3.5m | 40m | 5m |
| 50m | 6m | 60m | 7m | 70m | 8m |

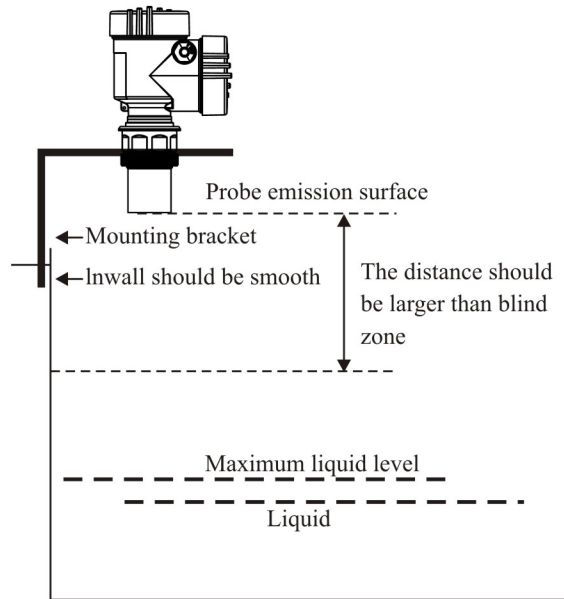

Open Vessel top -side part install one bracket to support

Open vessel don't have focusing effect, probe can be installed in the middle of top

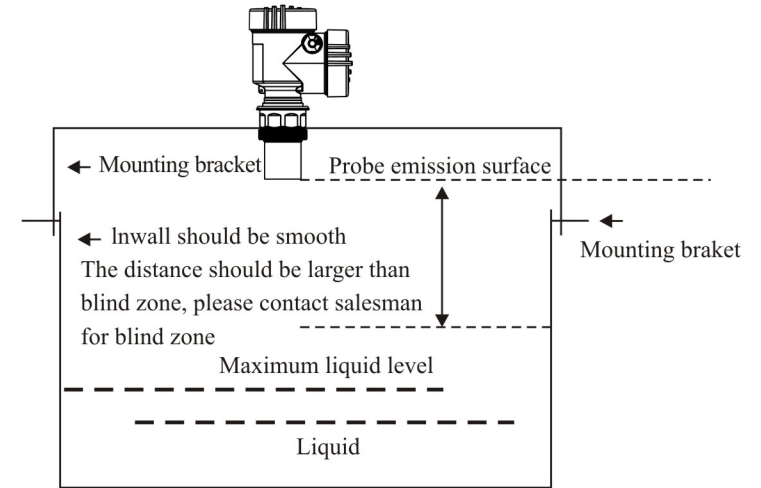

Open Vessel top-installed in the center of the top with bracket

4.2.3.4 Draining Well and Common Well

Well hole and well head of draining well are narrow, inner wall is irregularity and it's difficult to measure. It can be solved by installing guide tube or entire measuring casing, please note that, blind zone will increased to 50~100% if put the sensor into the guide tube, need take it into consideration.

if original blind zone of probe is 0.50m, it will increase to 1.00m after when using guide tube.

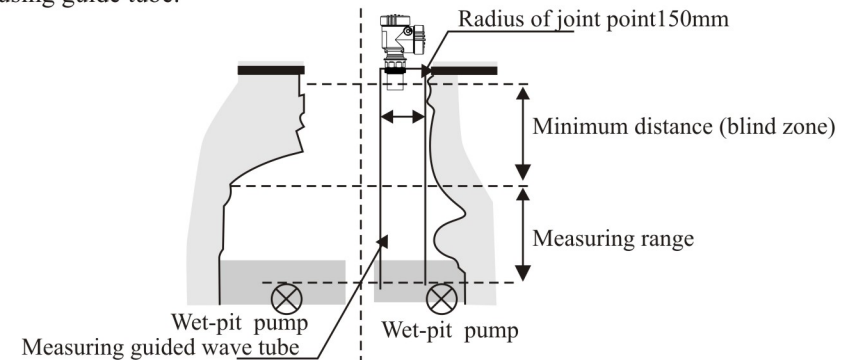

guide tube and measuring sleeve are used in the measurement of draining well

Generally speaking, Common well (include water supply well and deep well) diameter is not large and can install measuring sleeve to get better measurement. Inner wall of measuring sleeve should be smooth (can use PVC and PE), bore size $\geq 150\text{mm}$ (4m measuring range). Please contact us if you need measuring sleeve more than 4m. It can be measured if the measuring sleeve is clean, no adhesive medium and no joint.

Measuring casing should be immersed in the medium which makes sure measurement .

4.3.1 Measure Solid

4.3.1.1 Flange Installation

Same as measuring liquid, ultrasonic level meter can be installed on the counter flange of vessel guide tube, due to the reflecting surface of solid is not a plane as the liquid,so user need take into consideration of this problem. Probe emission surface should be vertical to the solid surface and probe should be extended outward from the guide tube.

In the application of solid measuring, if probe is inside of the guide tube, will result in measuring data fluctuating or sonic wave lose phenomenon under most circumstances.

Universal flange can be used to solve the problem, probe will easily point to solid surface while turning the universal flange.

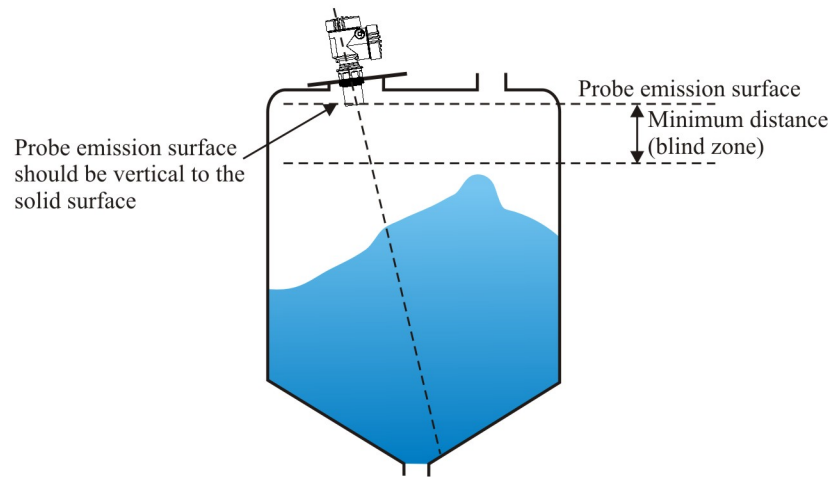

Integral type probe — install on vessel flange

4.3.1.2 Installation of Nipple Joint

Probe should be 2cm longer in the bottom side compare with guide tube when install nipple joint.

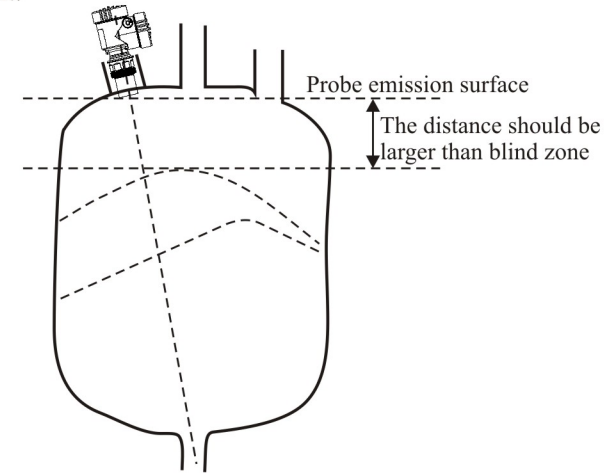

Integral type probe — install on nipple joint

4.3.1.3 Gantry Frame Installation

Open vessel can adopt gantry frame installation. Axis of guide tube should point toward with the outlet of vessel or vertical to the medium surface.

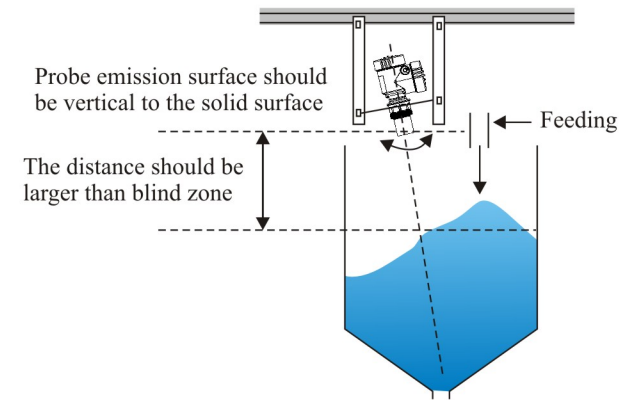

Integral type -- Gantry frame installation

When measure large open-pit pile, multiple ultrasonic level meters should be used, they can be installed on hoist frame and probe should point toward the surface of medium.

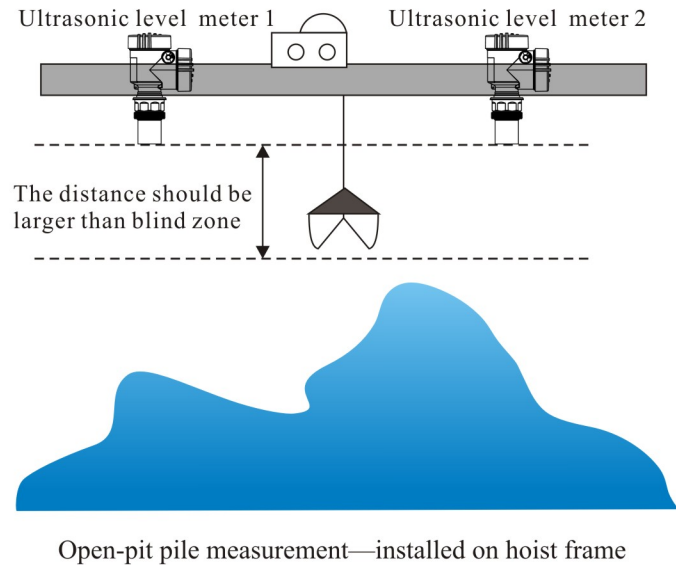

4.3.2 How to extend guide tube when measure solid

Probe should keep the minimum distance from solid surface, this is commonly called blind zone. But site condition can't meet the minimum distance requirements sometimes, one extended guide tube should be installed.

4.3.2.1 How to extend guide tube when measure liquid

Please try to keep inner wall smooth, guide tube should not be immersed in the medium in case of the pollution of the medium or adhere to the inner wall of guide tube.

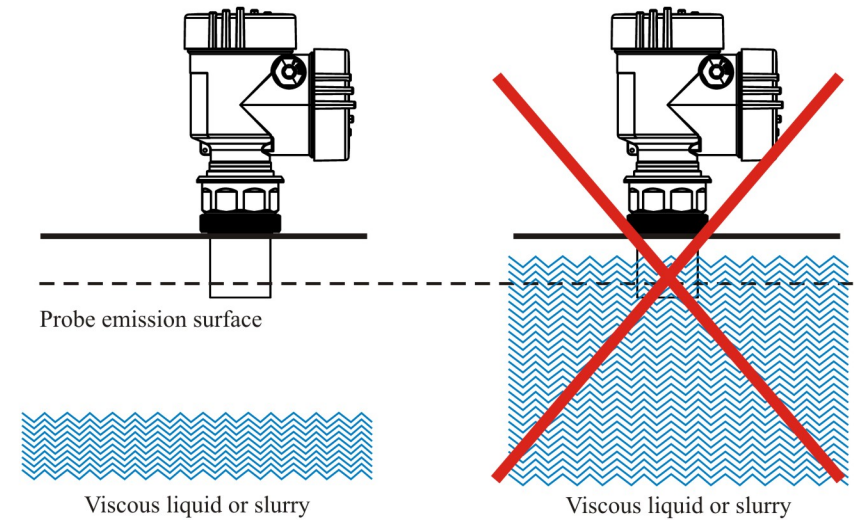

Guide tube can't be immersed in viscous medium

If it is non-adhesive medium, the extension guide tube can be immersed in the medium for a long time (cant be corroded by liquid, or without impurities adhere to the inner wall of the pipe), the measurement will be more accurate, because the measurement will not be influenced by other medium inside the container.

The inner diameter of the guide tube should be as large as possible, and the beveled slit should be smooth. The figure for guide tube length L and min bore size of guide tube ϕ is shown in the following table.

| No. | Length of guide tube (L) | Min bore size of joint pipe ϕ | Note |
|-----|--------------------------|------------------------------------|---|
| 1 | 150mm | 100mm | No burr and protruding object of inner wall of joint pipe, keep vertical, all welding joint should be polished, the joint pipe and tank top connection point need make an angle of 45 ° polished from the inside to the outside of the joint pipe |
| 2 | 200mm | 150mm | |
| 3 | 250mm | 180mm | |
| 4 | 300mm | 220mm | |
| 5 | 400mm | 280mm | |

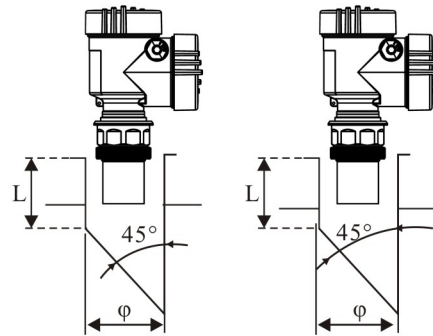

Extended guide tube not immersed in the medium

If extended guide tube is installed from top to bottom of tank, please refer to below figure for measuring range and bore size.

| Max measuring range | Min bore size (can be larger) | Max measuring range | Min bore size (can be larger) |
|---------------------|-------------------------------|---------------------|-------------------------------|
| 5m | 150m | 10m | 200m |
| 15m | 250m | 20m | 300m |

How to expand the measuring solid connection pipe

If the solid medium, unlike the measuring liquid, a tapered extension tube with angle of 25°C~30°C is needed;

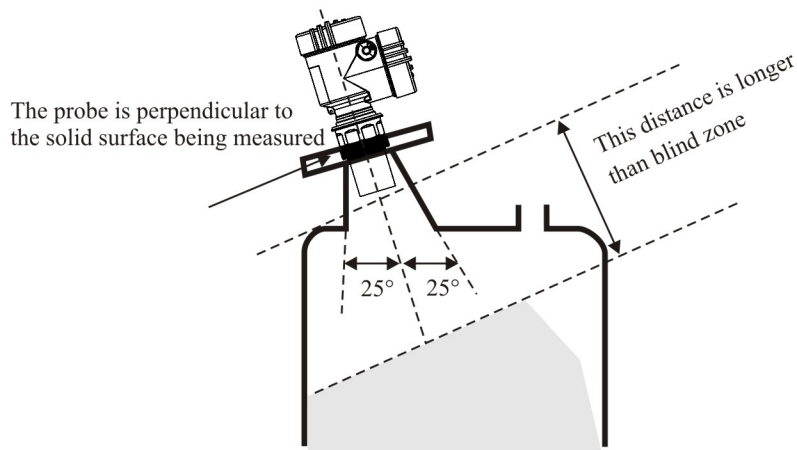

Extension for measuring solid medium

4.3.3 Installation to Avoid False Echoes

4.3.3.1 The device and installation in the container

When installing the sensor, it must be noted that other device or feeds not allowed to block ultrasonic beam. Bulges or step-like obstacles in the inner surface of the container can greatly influence the measurement, A refractor plate can be put in the bulges to deflect the false echo away, so as to ensure the accuracy of the measurement.

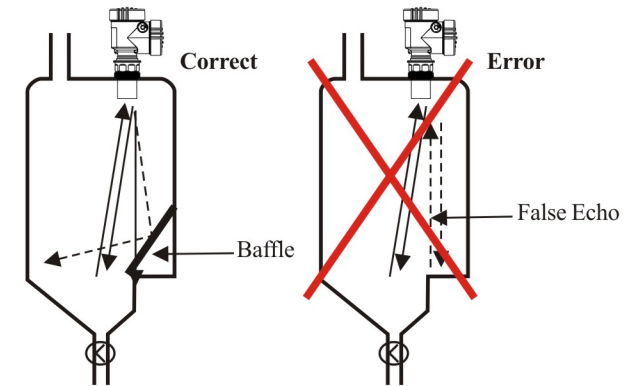

A step-like obstacle in the container--requires an inclined transverse plate to refract the false echo away.

If the upper surface of an object is planar at the bottom of the container, It must be shielded by a refractor plate with a certain angle.

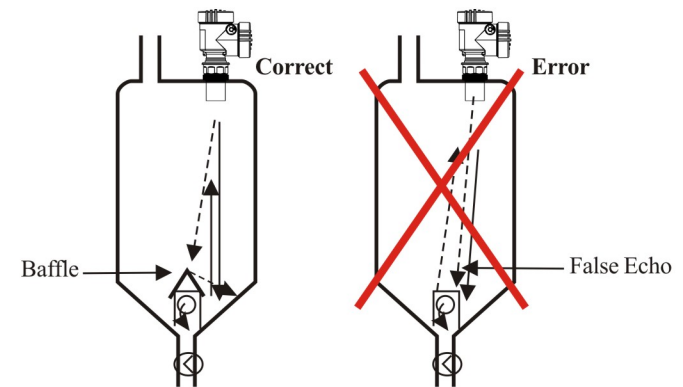

The bottom of the container has a plat-topped protrusion--need to add a refracting plate

The device in the container, such as: tubes and brackets, can affect the measurement. In the design of the measurement point, it must be noted that there must be no other devices within the diffusion range of the ultrasonic signal.

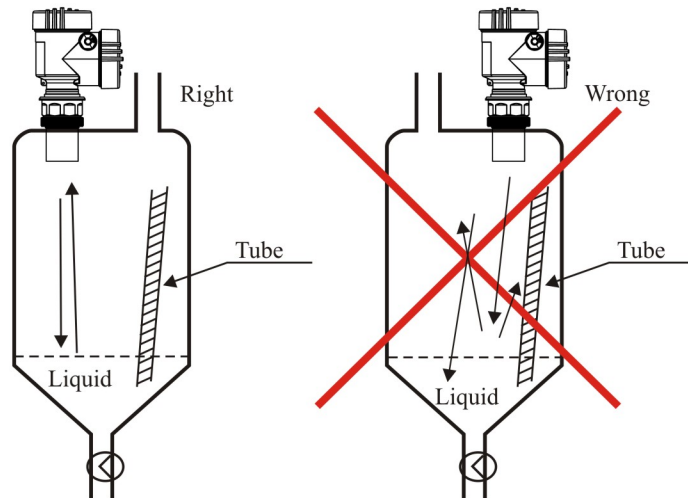

Don't install the sensor in or above the feed flow, leaving a certain distance from the feed inlet.

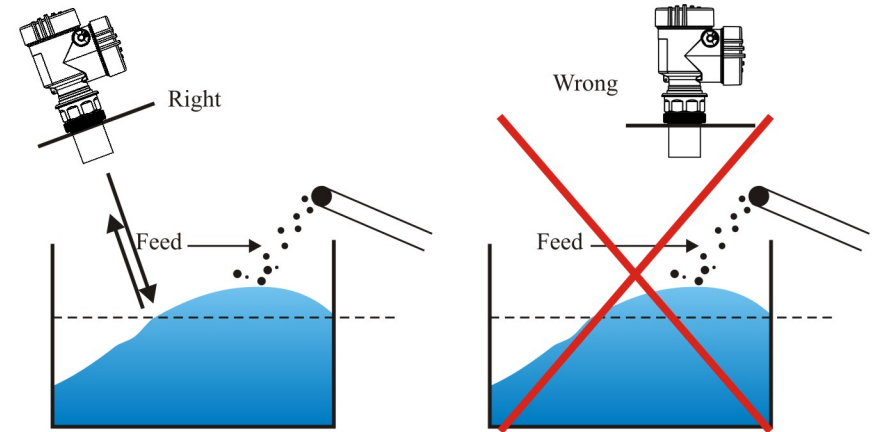
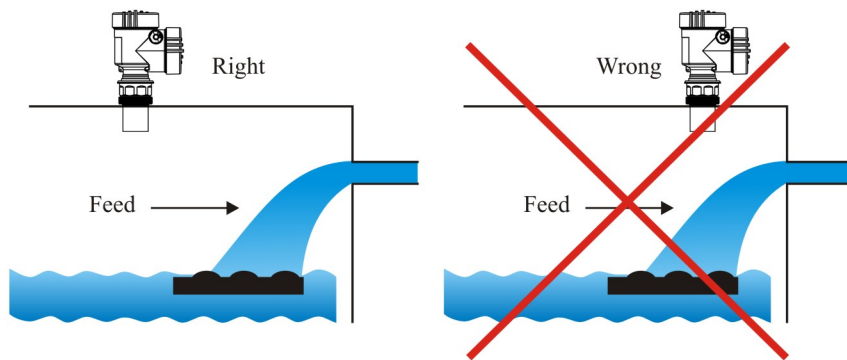

Don't install the sensor in the material flow of feeding or feeding top

There has adhesive medium in the container, such as: crude oil storage tanks, mud tanks, asphalt tanks, cement mixing tanks. If the sensor is installed too closed to the wall of the container, the adhesive medium on the wall of the container will cause a strong false echo, so the sensor should be kept at a certain distance from the wall of the container.

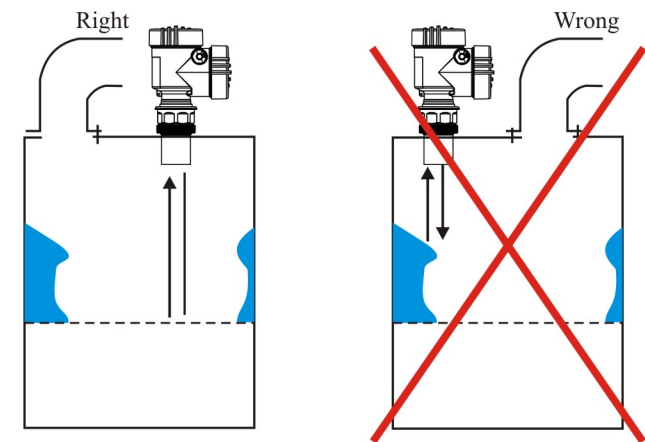

Adhesive medium on the wall of container---keep a distance from the adhesive medium

In the reservoir, according to the highest water level to decide the installation height of the instrument usually, it must be noted that the distance from the highest water level to the sensor, if there is obstacles when low level, it must be refracted with a baffle.

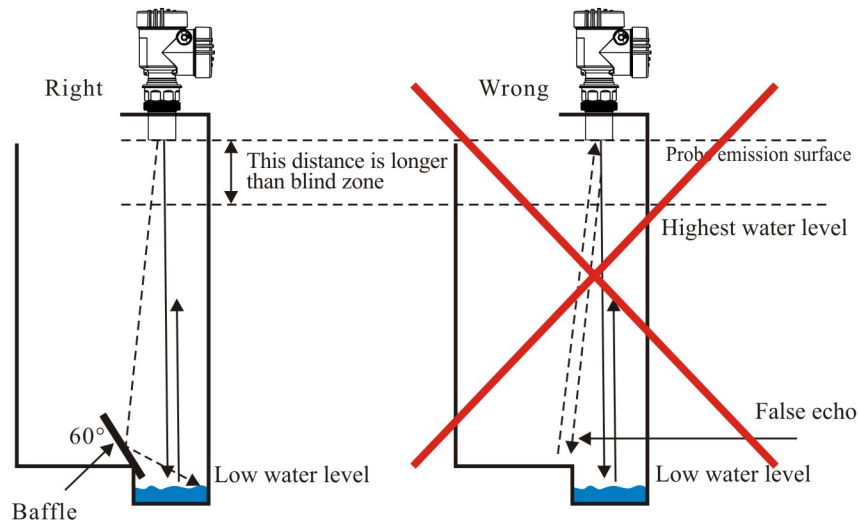

Obstacles at the bottom of the reservoir-- refraction with a baffle

If there are strong eddy, swirl in the container, such as the eddy caused by a agitator or a strong chemical reaction, the measurement will be very difficult. Ideally, the sensor probe can be installed in a wave guide or bypass tube for measurement.

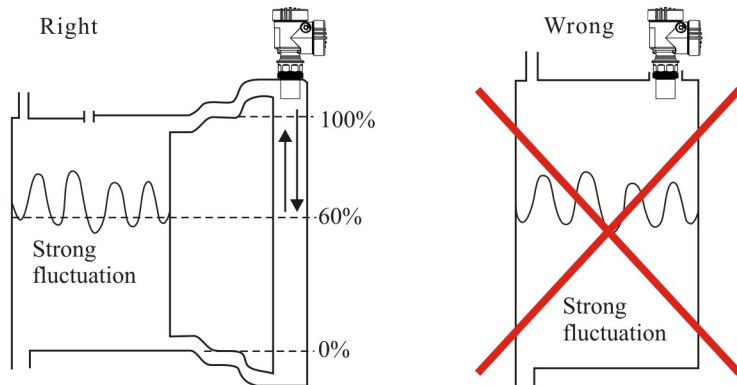

Large fluctuations at the surface of the medium --measured by bypass tube or wave guide tube

4.3.3.2 Common Installation Error

① Bubble: if the bubble on the surface of the medium is large and the layer of the bubble is thick, the measurement errors occur, the reflected ultrasonic wave may not be received. Take measures to prevent air bubbles from forming, or install the sensor in the bypass tube for measurement.

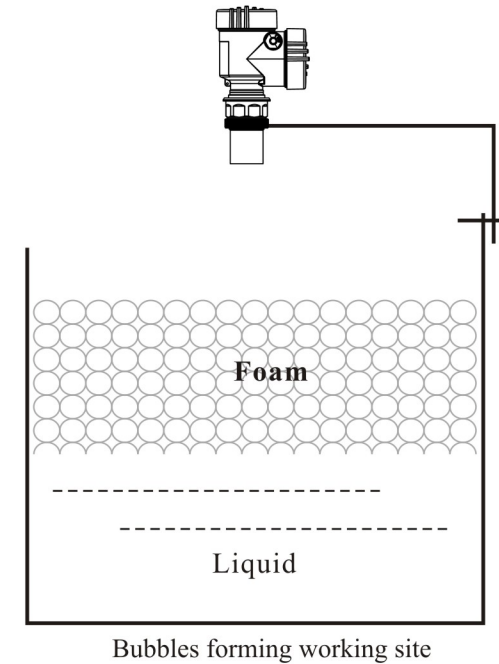

② The sensor is installed in the wrong direction
 If the sensor is misaligned with the surface of the medium, the measurement signal will be weakened. In order to ensure the best measurement effect, the sensor axis should be aligned to the surface, which is perpendicular to the measured interface surface.

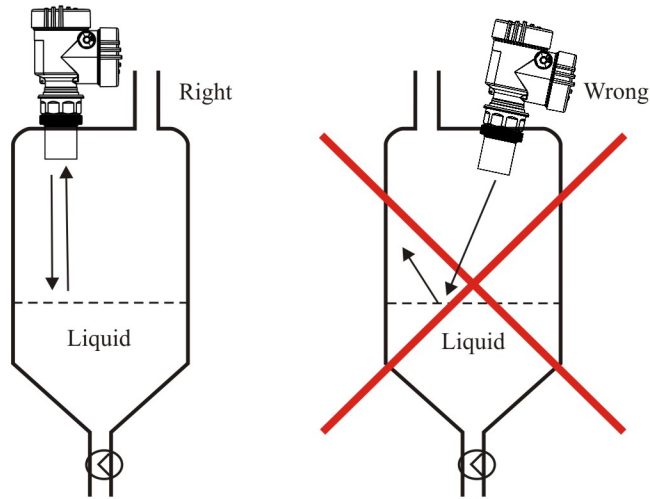

Sensor probe should be perpendicular to the medium surface

③ Installed in a location with a large temperature variation

In places with large temperature variation, such as strong solar radiation, measurement errors will occur. This error will increase 2-4% based on the original measurement accuracy. Please install a sun shield to solve this problem.

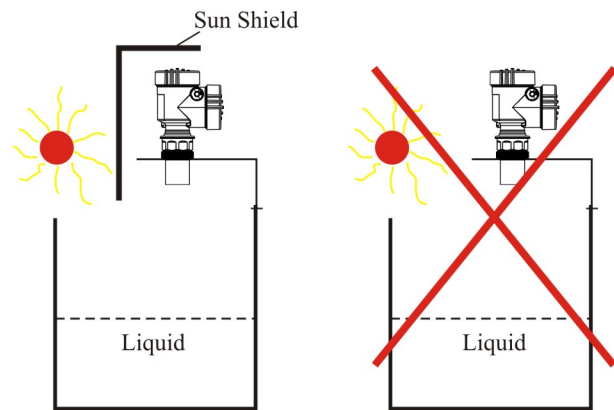

Large temperature change-- Adding sun shield or instrument box

④ The minimum distance to medium is less than blind zone

If the distance from probe to the highest of the medium is less than blind zone of the level meter, the measured value are all wrong.

⑤ The distance of the sensor too close to the container wall

If the distance of the sensor is closed to the wall of container, will produce a strong false echoes. The rugged inner surface of the container wall, the adhesive medium, the rivets, screws, ribs and welds on the inner wall of the container create strong false echoes and are loaded on the effective echo signals. Therefore, please note keep the distance between sensor and the container wall according to the maximum distance to be measured. Please see the table below for details.

| Max.range | Distance from the wall |
|-----------|------------------------|
| 5m | 0.5m |
| 10m | 1.0m |
| 15m | 1.5m |
| 20m | 2.5m |
| 30m | 4m |
| 40m | 5m |
| 50m | 6m |
| 60m | 7.2m |
| 70m | 8.5m |

For worse measuring conditions, continue to widen the distance between sensor and the wall of the container until there is no false echoes.

5. Wiring

5.1 Output Active

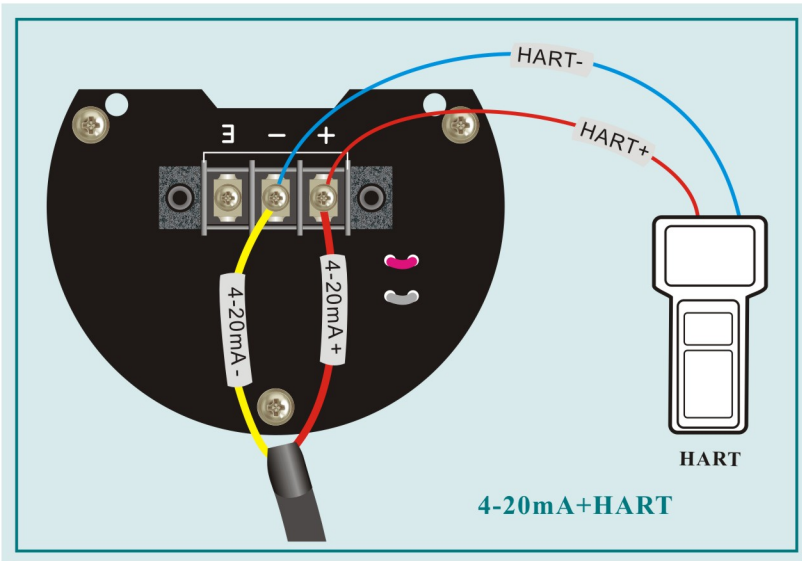
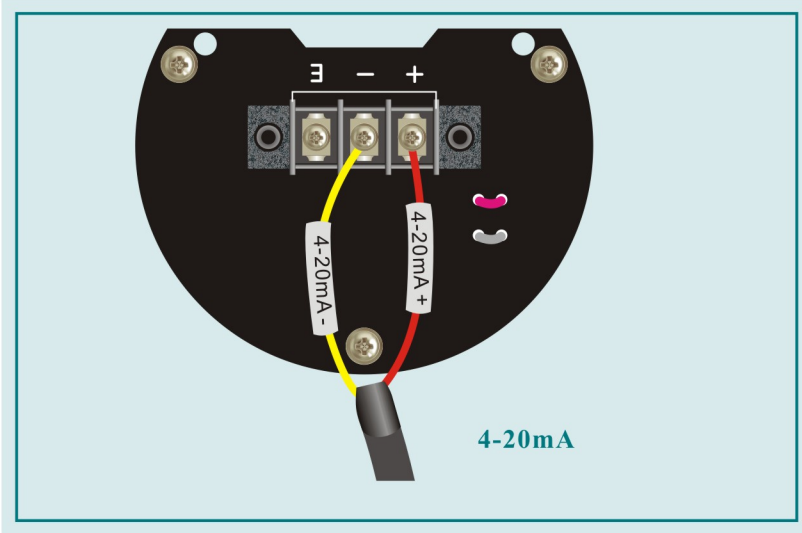

5.2 Output Passive

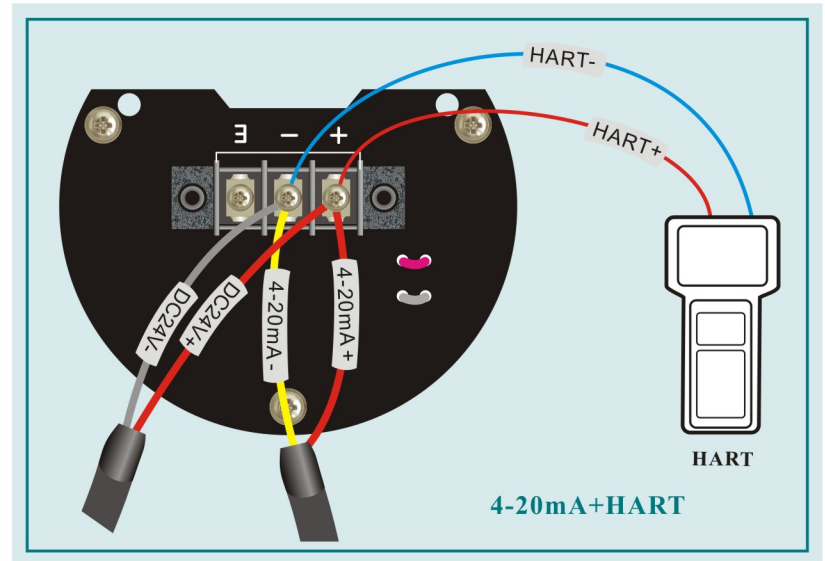
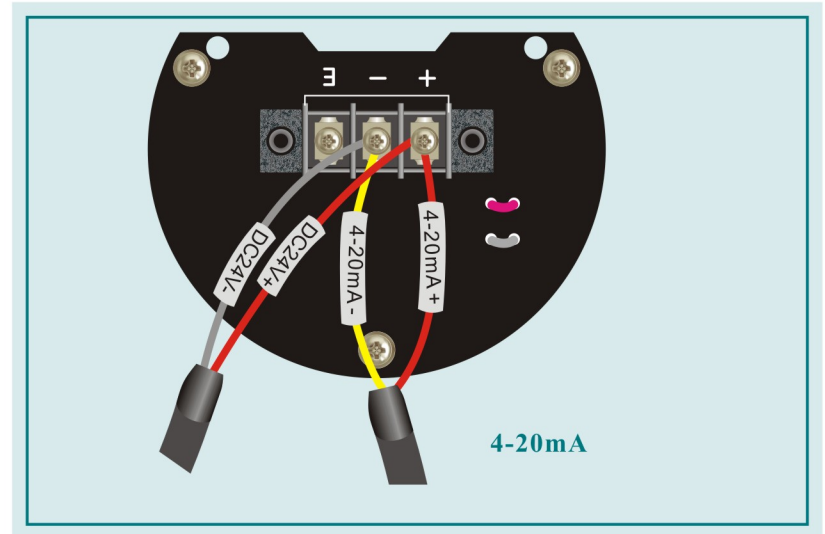

6. Setting

6.1 Interface in Operation Mode

There are two working modes: operation and setting. It will enter into operation mode automatically and start measuring data after the device is powered on and the initialization process is completed. At this time, the measurement is level measurement mode. And the relative output is 4-20mA. The output current is proportional to the level.



Operation mode interface is as follows:

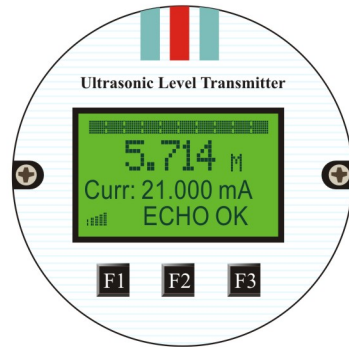

LCD display screen after opening the cover

Button Operation

There are F1、F2 and F3 three buttons



| |
|---|
| ● Press F3, enter setting function, can view and modify the parameters; |
| ● Press F1, page down (back to previous menu), press F2, page up (turn to the next menu) |
| ● Press F1 for three seconds, enter the current menu setting, when the underline goes to the second line, indicating the parameters can be modified; |
| ● Setting data: press F1 modify current data, press F2 right shift setting; Change the options: press F1 page up, press F2 page down; |
| ● Save data: press F1 for three seconds to save the setting; Meanwhile underline return to the first line, then can scroll down the menus by F1 and F2; |
| ● Exit setting: press F3, discard the current setting data; or return to previous menu / exit the setting; |

6.2 Interface Introduction

LCD adopt 128*64 lattice display, Multi variable simultaneous display is supported.

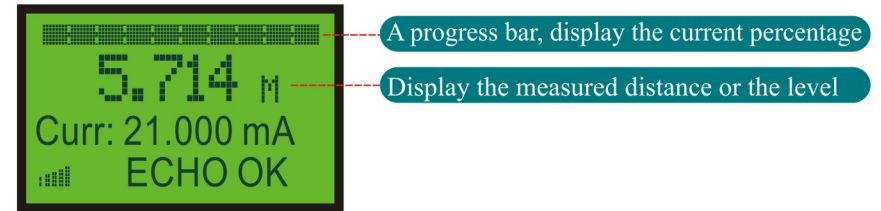

A progress bar, display the current percentage

Display the measured distance or the level

Press F1 until the second line switch to next data, loosen the button. Then press F1 to show variable switching between percentage, temperature, and distance.

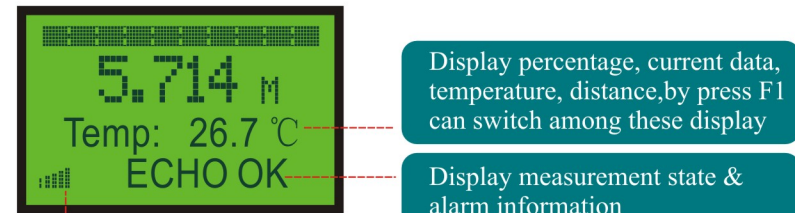

Display percentage, current data, temperature, distance, by press F1 can switch among these display

Display measurement state & alarm information

Display the current signal state

If there's no signal detected, the signal indicator will disappear.

Measurement Status Introduction:

| | |
|-------------------|---|
| ECHO OK | ECHO Measurement is normal, signal strength show on left side |
| Er:01-Comm fail | Hardware failure |
| Er:02-Comm Prof | Software version is wrong |
| Er:03-Echo Loss | ECHO Loss |
| Er:04-Large Noise | Excessive signal noise |
| Alm: Low Limit | below the low alarm limit |
| Alm: High Limit | above the high alarm limit |

6.3 Operation Menu

6.3.1 Basic Function Menu

| | |
|------------------|--|
| Contrast | Set the contrast of LCD display. |
| Protection | Set ON (Write Disable), Parameter are not allowed modified; Set the option "closed (Write Enable), can modify the parameter by pressing button. |
| Measure Mode | Can set it to measure Distance, level or empty. |
| Range Unit | Range unit can be mm, Cm, m, FEET, INCH. |
| Range 100% | Max Range, Set 20mA output corresponding distance value, level value, or empty value. |
| Range 0% | Lower Limit Range: Set 4mA output corresponding distance value, or level value, or empty value. |
| Damping (S) | Set range 0 ~ 32 second. Damping time longer, output is more stable, response time is longer. |
| Disp. Point | Set the main variable (data on the first line) display digits numbers after the decimal point. |
| Alarm Low | Set alarm low value , unit is same as the range unit. |
| Alarm High | Set alarm high, unit is same as the range unit. |
| Alarm High Hyst. | Set the alarm high hysteresis, unit is same as range unit. |
| Code | Input password, enter the corresponding advanced function settings. |

The password support as follows:

00050: advance setting, include measurement range (Maximum measure length), blind Zone, response rate, Echo algorithm selection and so on;

00060: set false echo suppression, probe excitation frequency;

00070: Sound velocity calibration, temperature calibration;

00011: check version number;

6.3.2 Password 00050 enter category operation menu

| | |
|----------------|---|
| Signal Monitor | Can check the current measure distance and signal strength. The farthest signal strength should be more than 1mV. |
| Slave Address | Set the converter communication address. |
| Measure Range | Set installation height, this parameter determines max measurement distance, recommended to set according to the actual condition. |
| Blanking | Set probe blind zone(0.2 ~ 2m), suggest to set according to probe parameter. |
| Response Rate | Set maximum response rate, can choose fast (10m/min), intermediate speed (1.0m/min) or slow (0.1m/min) |
| Echo Algorithm | Maximum value validation: Select the echo with maximum amplitude as the real echo. First wave: take the first effective echo as the real echo. |

In actual use, due to the difference of the measurement environment, the user should select the most suitable echo algorithm for measurement.

1. First select the "Maximum Confirmation" algorithm (factory default setting) for measurement, if it can be measured correctly, keep the algorithm unchanged; if the measured distance is greater than the actual distance, as shown in the figure below, change the algorithm to "First Wave", and then measure.

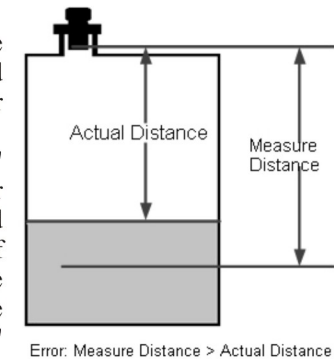

Use the "First Wave" algorithm for measurement. If the measurement can be done correctly, keep the algorithm unchanged; if the measured distance is smaller than the actual distance, as shown in the figure below, change the algorithm to "Maximum or First Wave" before measuring.

Select "Maximum or First Wave" only when neither of the first two algorithms can be measured correctly, and it will generally work normally after setting.

Remember to use the "Maximum or First Wave" algorithm only when the "Maximum Confirmation" and "First Wave" algorithms cannot be measured correctly, otherwise the measurement may be unreliable.

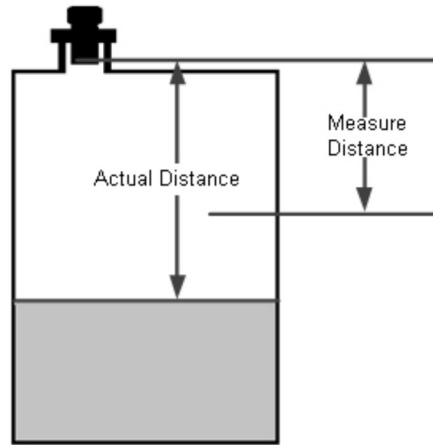

Measure Distance < Actual Distance

| | |
|----------------|---|
| Echo Lock. | Off: response to the echo immediately but it is limited by response rate . Max value mode (Max): when the number of the times for the echo exceeds the set echo sample A or echo sample B, it is the real echo. Agitator Mode (Agitator): ECHO Sample A default is 5, ECHO Sample B default is 2, work Mode as “max value mode”. When there is agitator, make sure choose “max value mode” or “agitator mode” |
| Sampling Up | When the number of times for the collected Echo in the upper(closer from the probe) exceed the set value, It is the real echo. |
| Sampling Down | When the number of times for the collected Echo at the bottom (farther from the probe) exceed the set value, It is the real echo. |
| Fail safe Mode | When the equipment failure, there are three modes of the main variable data output: keep the last valid value (Hold), error value,or customized value (Fail safe Value). |

| | |
|-----------------|--|
| Fail safe Value | User-defined fail-safe value, Unit is same as range unit. |
| Temp. Unit | Set temperature unit: °C, F, R, K. |
| Temp. Source | Can choose: sensor, or fixed temperature value. |
| Fixed Temp | When Temp.source select “fixed temperature”, use this menu to set the the temperature value. |

6.3.3 Password 00060 enter category operation menu

| | |
|------------------|---|
| Echo Algo.Coeff | Set the inhibition strength of false echo, Default is 50%. When there’s fake echo which is closer than real echo (closer to the probe)on the field , can increase the inhibition strength. |
| Noise Level (mV) | When there is “Er:04-LargeNoise”, need to increase the minimum threshold (used to suppress excessive noise in the field). Set range 75mV~400mV. |

Set probe excitation frequency. Current allowed setting range is 30kHz ~50kHz.

When need use 15KHz ~ 30KHz excitation, need to be add two capacitors.

6.3.4 Password 00070 enter category operation menu

| | |
|-------------------|--|
| Calib Sound speed | To calibrate sound speed, please input the actual distance to the probe. Remark: when first enter this menu, it will display the current sound speed. After enter setting, can input the current actual distance value. |
|-------------------|--|

| | |
|-----------------------|---|
| Sensor Freq (Khz) | <p>The speed of sound propagation in air and non-air (such as gasoline, acetone, alcohol and many other volatile gases) is different. Therefore, the speed of sound needs to be corrected in non-air situations to eliminate measurement errors caused by sound speed errors.</p> <p>There are 2 ways to correct the speed of sound: First, enter “Calib Sound Speed” Menu, input the actual distance of probe to the liquid level (unit:m), then press “F3” is ok. Note: before enter this menu, it displays current sound velocity, enter setting, could input current actual distance for correction. Second: Enter “Sound speed(20°C)” menu, input the sound velocity under 20°C, then press “F3” realize correction. Note: Without correction, use the 343.616m/s(air sound velocity at 20°C) as the default value.</p> |
| Sound speed (20°C) | Check the sound speed at 20°C after calibration. Can only check, not adjustable. |
| Set Offset | Can make the measured value bias by set the bias value. If set a positive number, the measured value will be increased. |
| Temp.Offset | When the temperature value is not accurate, can set this value and make the temperature value bias. If set a positive number, the temperature value will be increased. |
| Temp.Low Trim | Input the current actual temperature value to calibrate the temperature sensor. Note: Need to be set the menu Temp. High Trim at the same time. |
| Temp.High Trim | Input the current actual temperature value to calibrate the temperature sensor. Note: Need to be set the menu Temp.Low Trim at the same time. |